

MULTI-PORT SERIES (FLANGED) SERIES 280

FEATURES/SPECIFICATIONS:

- Available in 316 stainless steel
- Full port design
- ISO 5211 mounting pad (sizes 1/2"-4" are direct mounting)
- Investment cast and sand cast body construction
- Meets International Standards
- 150# ANSI Flanged ends
- L or T Port
- Size: 1/2"-12"

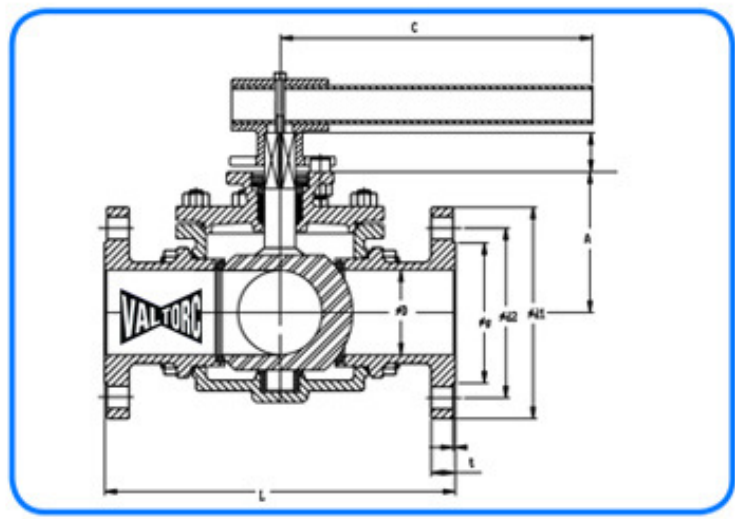
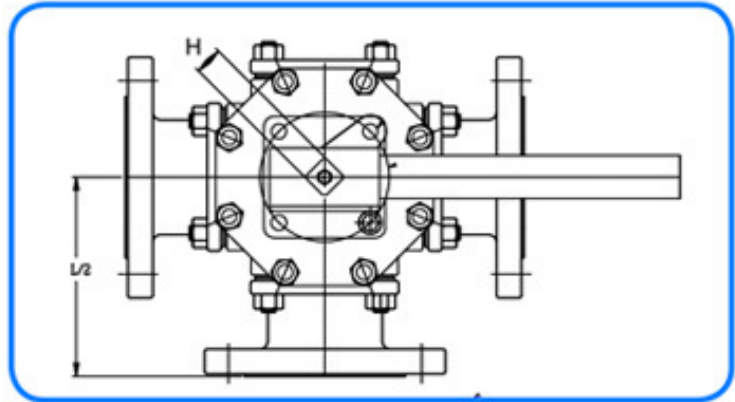

Size	A	C	D	L	d1	d2	g	t	Stem Height	H	ISO5211
1/2"	41	130	15	152	89	60.5	35	11.2	11	9	F03/F04
3/4"	49	165	20	167	98	70	43	11.2	14	11	F04/F05
1"	55	165	25	190	108	79.5	51	11.2	14	11	F04/F05
1-1/4"	63	205	32	208	117	89	64	12.7	18	14	F05/F07
1-1/2"	74	205	38	220	127	98.5	73	14.3	18	14	F05/F07
2"	93	325	50	253	152	120.5	92	15.8	23	17	F07/F10
2-1/2"	118.5	400	62	300	178	139.5	105	17.8	25	22	F10
3"	136.5	500	76	305	190	152.5	127	19.1	25	22	F10
4"	156.5	650	96	368.5	229	190.5	157	24	25	22	F10
6"	159.5	1200	150	427	279.3	241.5	216	25.4	36	36	F12

