

SERIES 5000 (DUCTILE IRON BODY KNIFE GATE VALVE)

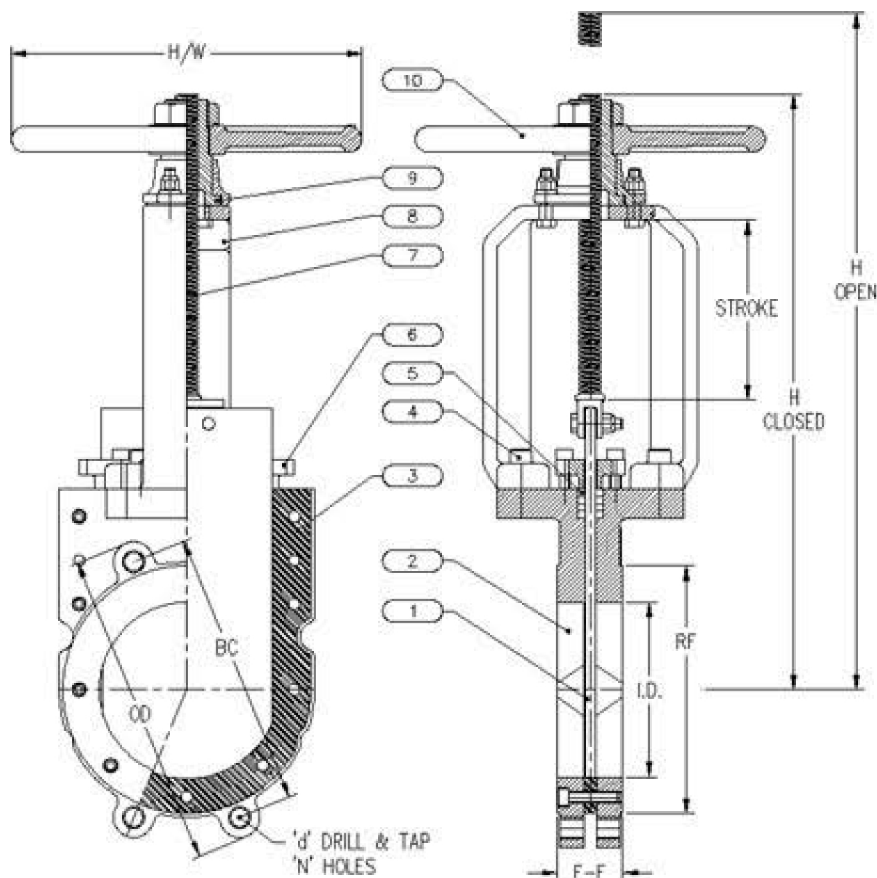
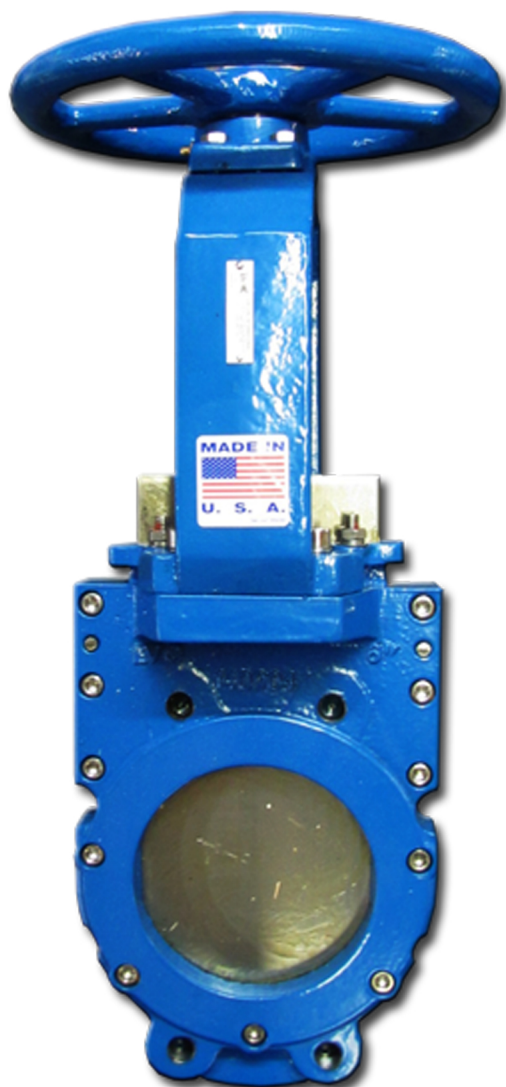

DIMENSIONS (INCHES) AND WEIGHTS

	SIZE	2	3	4	6	8	10	12	14	16	18	20	24
FACE-TO-FACE	F-F	1-7/8	2	2	2-1/4	2-3/4	2-3/4	3	3	3-1/2	3-1/2	3-1/2	4
FLANGE OD	OD	6	7-1/2	9	11	13-1/2	16	19	21	23-1/2	25	27-1/2	32
BOLT CIRCLE	BC	4-3/4	6	7-1/2	9-1/2	11-3/4	14-1/4	17	18-3/4	21-1/4	22-3/4	25	29-1/2
FLANGE RAISED FACE	RF	4	5	6-3/16	8-1/2	10-5/8	12-3/4	15	16-1/4	18-1/2	- FLAT FACE FLANGE		
INSIDE DIAMETER	ID	2	3	4	6	8	10	12	14	15-1/2	17-1/4	19-1/4	23-1/4
NO. OF BOLT HOLES	N	4	4	8	8	8	12	12	12	16	16	20	20
HOLE D&T SIZE	d	5/8"-11	5/8"-11	5/8"-11	3/4"-10	3/4"-10	7/8"-9	7/8"-9	1"-8	1"-8	1-1/8"-7	1-1/8"-7	1-1/4"-7
C/L TO TOP-CLOSED	H-CLS	13	14-1/4	16-1/4	20-1/8	24-1/4	28-1/2	34-1/2	40	44	47-3/8	51	58-1/4
C/L TO TOP-OPEN	H-OPN	15	17-1/2	20-1/2	26-1/2	32-1/2	38-3/4	47	54-1/4	56-1/4	64	72-1/4	82-1/4
HANDWHEEL DIA.	H/W	8	8	8	12	12	16	16	24	24	24	24	24
WEIGHT - LB'S	WT	19	29	46	75	118	180	295	345	455	545	800	1050