

GENERAL

ALIAVTX The ASF7100 Series Swirl Flowmeter is a gas flow meter that combines turbine & vortex flow measurement technologies to provide a reliable, high accuracy, robust, maintenance free flow meter. The turbine-shaped flow inlet causes the process flow to rotate causing a vortex core to form & a subsequent secondary rotation causes thread-like spirals to be formed. These resulting secondary pressure frequencies are linear & proportional & are measured by dual piezo-electric sensors. The resulting measurements are processed & pressure & temperature compensated and then converted to the flow measurement display. ASF7100 Series Swirl Flow meter can be widely used in petroleum, chemical, electricity, metallurgy, coal and other industries.

FEATURES

- 2 Integral sensors reduce external vibration / frequency interference
- No integral moving parts to ensure steady, reliable and long service life
- Integral temperature & pressure measurement ensuring actual compensation
- Multiple signal O/P's: 4-20 mA, Pulse, RS485, Alarm
- Adjustable display / readout (90°, 180°, 270°, 360°) Simple adjustment
- Battery powered, or external DC powered
- Reduced pressure loss due to internal piping configuration
- Reduced upstream / downstream straight pipe requirements

STANDARD SPECIFICATION

- | | | | |
|-----------------------|--|--------------------|---|
| ● Size | : 15, 20, 25, 32, 40, 50, 65, 80, 100, 125, 150, 200 mm (1/2", 3/4", 1-1/4", 1-1/2", 2", 2-1/2", 3", 4", 5", 6", 8") | ● Local Display | : 4 lines LCD
: 7 Digit flowrate
: 8 Digit + 4 Decimal totalizer |
| ● Measuring Range | : 0.3-3600 m ³ /hr | ● Unit | : Nm ³ /hr, m ³ /hr, kg/hr |
| ● Accuracy | : +/-1.5% of reading (Standard)
: +/-1.0% of reading (Option) | ● Keypad | : 3 Internal keys for programming and display configuration |
| ● Housing Material | : Aluminum Alloy | ● Current Output | : 4-20 mA (2 wire, 4 wire)
Load : Rohm=(VDC-15) * 50
Output Unit : Normal flow rate / Actual flow rate |
| ● Body Material | : Cast Aluminum Alloy
: Stainless Steel 304
: Stainless Steel 316
: Stainless Steel 316L | ● Pulse Output | : Active Frequency / Scale Pulse
Rating : 24 VDC, 50 mA Max. |
| ● Process Connection | : Flange Type | ● Alarm Output | : 2 Relays, Upper and lower alarm
Rating : 5A 30 VDC / 5A 250 VAC
Output Unit : Normal flow rate / Actual flow rate / T / P |
| ● Flange Type | : JIS 10K / JIS 20K / JIS 40K
ANSI 150# / ANSI 300# / ANSI 600#
PN10 / PN16 / PN25 / PN40 | ● Communication | : RS485 (MODBUS) |
| ● Max. Pressure | : Cast Aluminum Alloy, Max. 16 kgf/cm ²
: Stainless Steel, Max. 64 kgf/cm ² | ● Data Storage | : Operation parameter and totalizer figures are stored by EEPROM (>10 yrs.) |
| ● Medium Temperature | : -20~80 °C | ● Cable Entry | : Standard: M20 * 1.5 Option: 1/2" NPTF |
| ● Ambient Temperature | : -20~65 °C | ● Protection Class | : IP65
: Explosion Proof, Ex d IIC T4-T6 |
| ● Power Supply | : 15-30 VDC (2 Wire)
: 24 VDC ±15% (4 Wire)
: 3.6V Battery, Size C | ● Sensor | Pressure Sensor : Piezoresistive silicon Sensor
Temperature Sensor : RTD |
| ● Power Consumption | : <2W (24 VDC) | | |
| ● Battery Life | : More than 2 years (3.6V Battery) | | |



FLOW RANGE

Size		Flow Range (Nm ³ /hr)											
mm	inch	20 °C											
		0 bar G		2 bar G		4 bar G		6 bar G		8 bar G		10 bar G	
		Min.	Max.	Min.	Max.	Min.	Max.	Min.	Max.	Min.	Max.	Min.	Max.
15	1/2"	0.3	12.0	0.8	33.2	1.4	55.3	2.0	77.3	2.5	99.4	3.0	121.5
20	1-1/4"	1.2	15.0	3.3	41.5	5.5	69.2	7.7	96.7	9.9	124.3	12.2	151.9
25	1"	2.5	30.0	6.9	83.1	11.5	138.3	16.1	193.5	20.7	248.7	25.3	303.8
32	1-1/4"	4.5	60	12	166	21	277	29	387	37	497	46	608
40	1-1/2"	7.0	70	19	194	32	323	45	451	58	580	71	709
50	2"	10.0	130	28	360	46	599	64	838	83	1078	101	1317
65	2-1/2"	20.0	300	55	831	92	1383	129	1935	166	2487	203	3038
80	3"	30.0	400	83	1108	138	1844	193	2580	249	3315	304	4051
100	4"	50.0	800	139	2217	231	3688	322	5159	414	6631	506	8102
125	5"	80.0	1000	222	2771	369	4610	516	6449	663	8289	810	10128
150	6"	190.0	1900	526	5265	876	8759	1225	12254	1575	15748	1924	19243
200	8"	240.0	3600	665	9975	1106	16597	1548	23218	1989	29839	2431	36460

WIRING DIAGRAM

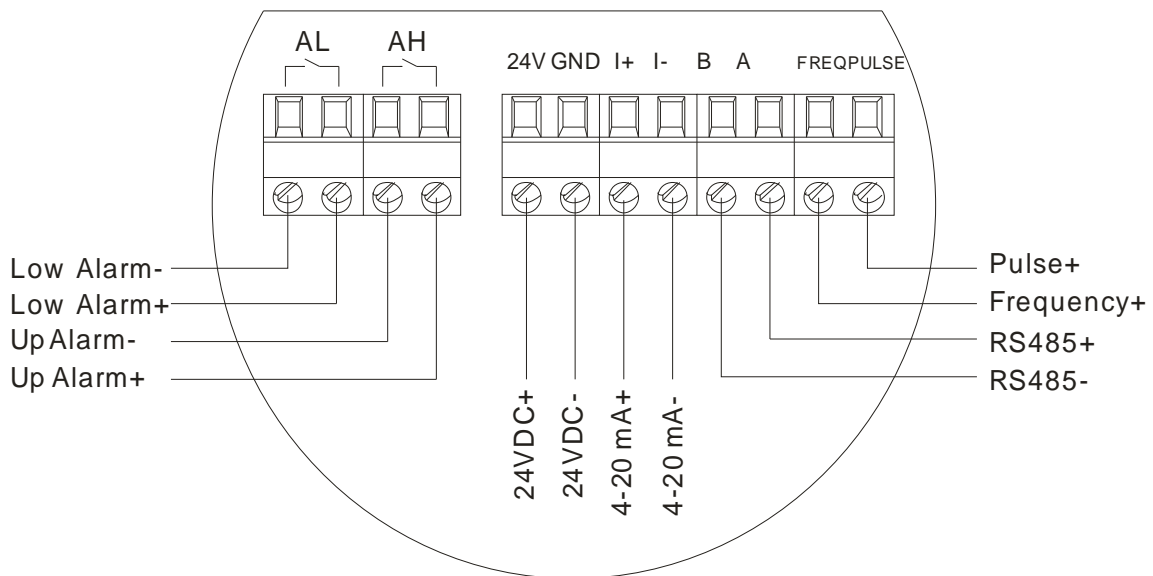

STRUCTURE DIAGRAM

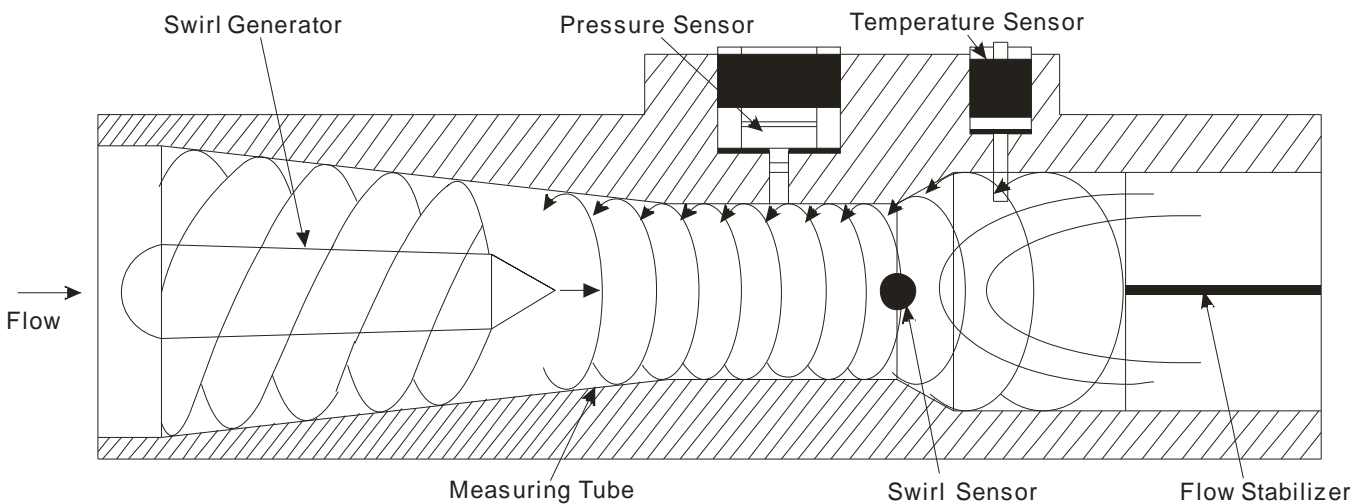

DIMENSIONS

Size		L (mm)	H (mm)	A (mm)	B (mm)	Weight (kg)	
						Cast Aluminum	S.S
15	1/2"	160	305	130	140	5.8	7.0
20	3/4"	160	305	130	140	6.0	10.0
25	1"	180	315	130	140	6.0	10.0
32	1-1/4"	200	330	130	140	7.0	12.0
40	1-1/2"	232	355	130	140	8.5	12.5
50	2"	232	365	130	140	9.0	15.0
65	2-1/2"	330	390	130	140	11.0	22.0
80	3"	330	400	130	140	13.0	23.0
100	4"	410	420	130	140	14.5	34.0
125	5"	580	470	130	140	24.0	45.0
150	6"	580	490	130	140	33.0	56.0
200	8"	700	540	130	140	42.5	83.0

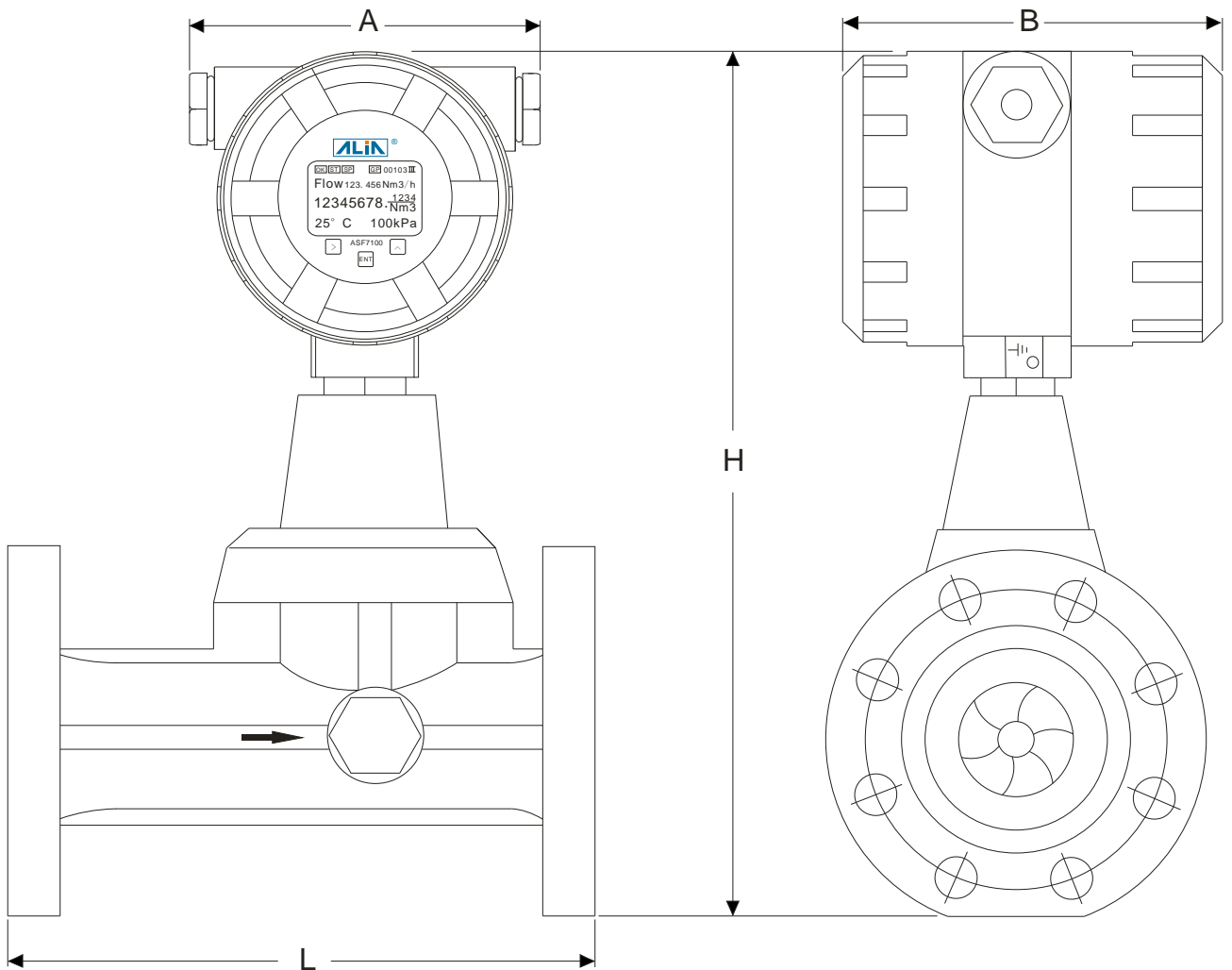

CONDITIONS ON STRAIGHT PIPE

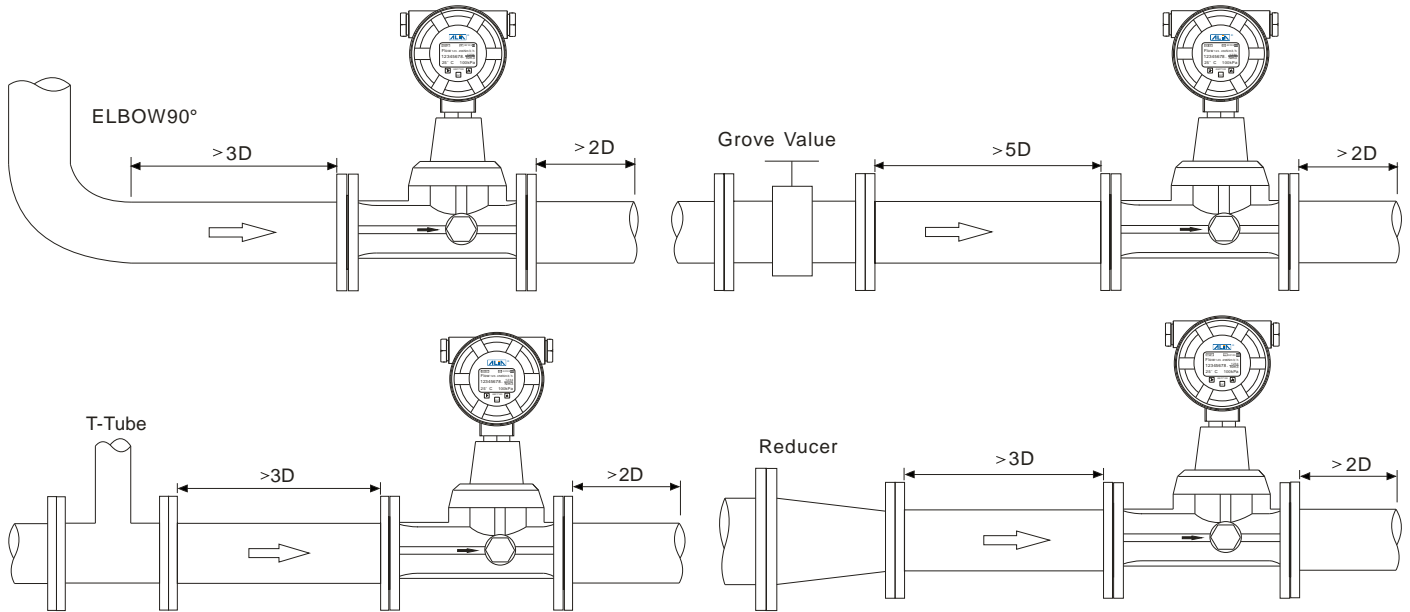

MODEL SELECTION GUIDE

ASF7100 Series						
Example: ASF7100-S6-050-AA-PT						
ASF7100-	-XX	-XXX	-X	X	-XX	Description
Material	-AL					Cast Aluminum Alloy (Max. 16 kgf/cm ²) * Note
	-S4					Stainless Steel 304
	-S6					Stainless Steel 316
	-SL					Stainless Steel 316L
Size		-015~200				015-200 mm (1/2"-8")
Process Connection			-1			PN10
			-2			PN16
			-3			PN25
			-4			PN40
			-A			ANSI 150#
			-B			ANSI 300#
			-C			ANSI 600# (Max. 64 kgf/cm ²)
			-J			JIS 10K
			-K			JIS 20K
			-L			JIS 40K
		-Z			Others	
Output			N			Battery Powered (Display Only, Without Output)
			A			4-20 mA (2 wire) or Active Pulse or RS485
			B			4-20 mA (4 wire) + Active Pulse + RS485 + Relay Alarm
Option			-NN			None
			-EX			Explosion Proof, Ex d IIC T4-T6
			-PT			Cable Entry 1/2" NPTF

Note: The process connections for cast aluminum alloy except for 25A JIS 10K, 4"-8" ANSI 150#.