

HYCONTROL

PRODUCT



MICROWAVE LEVEL SWITCHES – HYCMWS

MICROWAVE LEVEL SWITCH

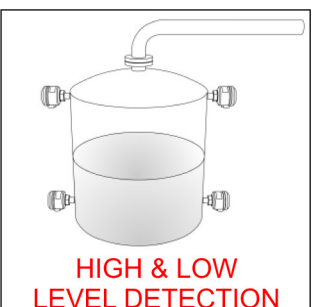
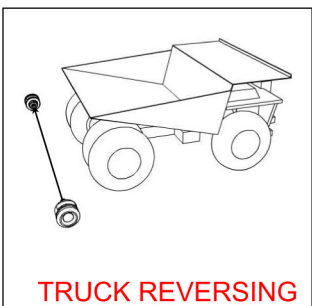
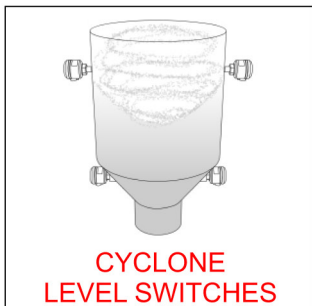
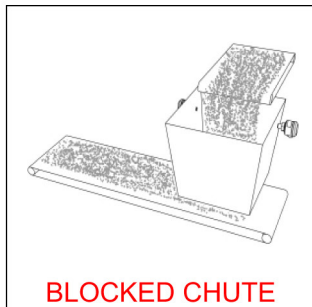

MICROWAVE LEVEL SWITCH

This range of Microwave level switches provides a simple non-contact, non-intrusive option suitable for many applications on powders and solids. An installation comprises of a transmitter and a receiver which are mounted facing one another at distances up to a maximum of 40m apart.

During operation the transmitter emits a continuous, low power, microwave beam to the receiver and an output relay is energised or de-energised when this beam is obstructed by the material being monitored. The switch trigger point is determined by the amount of microwave energy received and can therefore be adjusted to cater for different products and different sensitivity settings depending upon the application.

Typical applications for detecting presence and non-presence of materials include flow and no flow conditions, point level detection, blocked chute detection and also proximity switch detection for reversing vehicles such as quarry trucks and rail cars.

MICROWAVE FEATURES

NON CONTACT PRINCIPLE

The switches can be installed behind various window materials such as Teflon or Polypropylene to maintain the integrity of the vessel or chute even if they need to be removed.

HIGH PENETRATION AND SURFACE COATING IMMUNITY

The microwaves easily penetrate any surface contaminants which makes the switches ideal for applications with high build up on the tank or silo walls. This switch is also immune to problems with airborne contaminants such as dust or steam.

SIMPLE INSTALLATION AND SET UP

A wide beam angle on the transmitter sensor enables alignment to be carried out easily for the two sensors. The received power level is also clearly indicated by a bank of 15 LEDs which enable clear visual indication of the state of power received and the location of the switch setpoint (see opposite).

TOTAL SAFETY FOR OPERATORS AND SITE PERSONNEL

This device requires no special procedures for its operation and use as power limitations are well below any required industry standards.

NEW HETERODYNE DETECTION PRINCIPLE

Many older microwave switches employ a diode detection technology but this new range uses the Heterodyne detection principle which has the ability to obtain a proportional output to the power received. This enables the switch to increase its operating range and penetrability without having to increase the power of transmitted microwave signal.

EASY RETROFIT TO NEW AND EXISTING TANKS

A wide range of flanges and a standard 1" BSPP process thread make this range extremely easy to retrofit to new and old installations utilising existing process connections.

ALIA
MUESEN
SAGE
HYCONTROL
KONICS
WIKA
HBE
서진인스텍
서전발맥
KDI

초음파 레벨계
Microflex C
Miniflex LR
Microflex LR
Reflex LR
레이더 레벨계
Reflex VG5
Reflex VG6
Reflex VG7
Reflex VF3
Reflex VF7
레벨스위치
액체형 vibration
분체형 vibration
Microwave

ADVANTAGES AND BENEFITS

- ◆ Non-contact technology with no moving parts reduces maintenance costs
- ◆ Versatile technology for liquids, slurries, solids, pellets and powders
- ◆ Long measuring range up to 40m with adjustable sensitivity to suit most applications
- ◆ Simple to install and commission leading to reduced installation costs
- ◆ Immune to coatings on tank walls improving reliability and reduces maintenance costs
- ◆ Non-invasive technology, with no long probes to insert, internal product build up is reduced
- ◆ Suitable for demanding environments such as corrosive, high dust, high vibration or vapours
- ◆ Chemical resistant window options for corrosive applications

MICROWAVE LEVEL SWITCH

SIMPLE COMMISSIONING WITH LED ADJUSTMENT

The sensitivity is adjusted visually using the 15 LED indicator array. The received power level and sensitivity set-point are indicated on the receiver by a bank of 15 LEDs. The received power is clearly indicated by the brightest LED. Then, by a simple adjustment screw, the relay set point (dimmer LED) can be adjusted either way.

This system allows for a very clear visual sensitivity adjustment and greatly simplifies maintenance and commissioning as the switch positions and sensitivity are seen at a glance.

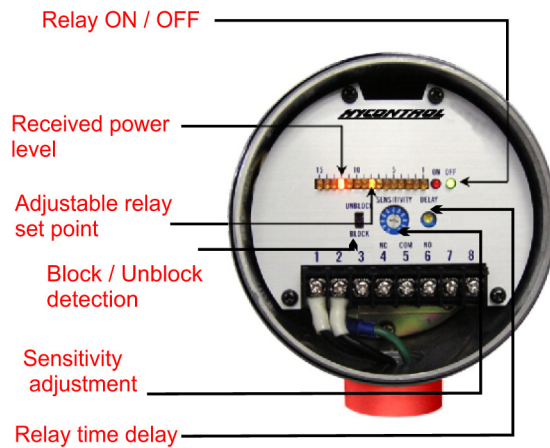
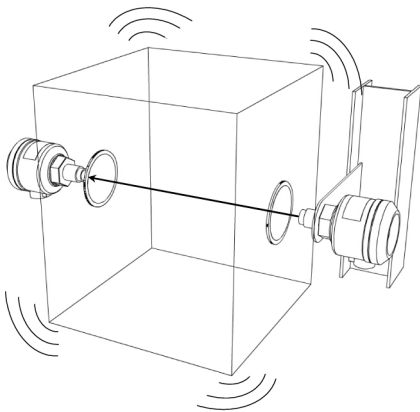

HIGH VIBRATION & HAZARDOUS APPLICATIONS USE ISOLATED, NON-INVASIVE MOUNTING

Sensors may be protected from high temperatures, hazardous materials, vibration and shock by providing detecting windows through which the microwaves can pass.

Detecting windows should be made of non-metallic materials such as ceramic, glass, teflon or polypropylene. With these materials there is minimal loss of microwave energy between the two sensors.

The detecting windows should be at least 60mm in diameter as microwaves pass more easily through larger apertures. The distance between the window and sensing face should be less than 200mm.

MOUNTING OPTIONS

STANDARD

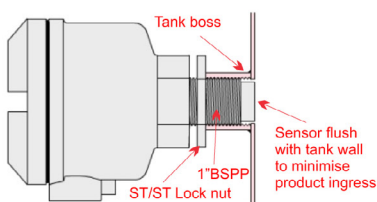

Standard 1" BSPP process connection directly into the tank socket. Suitable for low abrasion applications.

FLANGE

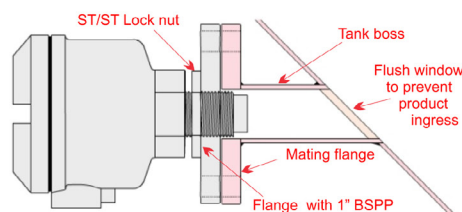

Flange with 1" BSPP process connection through a flange socket with Teflon window. The angle of the tank wall will have little or no effect on the transmitter.

FLANGE WITH INSERT

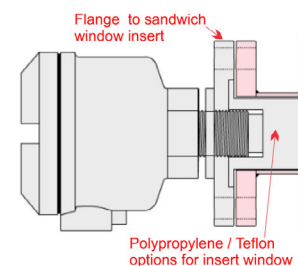

Flange process connection with optional polypropylene plug sandwiched between flanges but flush with tank wall. This provides additional sensor protection.

ALIA
MUESEN
SAGE
HYCONTROL
KONICS
WIKA
HBE
서진인스텍
서전발맥
KDI

초음파 레벨계
Microflex C
Miniflex LR
Microflex LR
Reflex LR
레이더 레벨계
Reflex VG5
Reflex VG6
Reflex VG7
Reflex VF3
Reflex VF7
레벨스위치
액체형vibration
분체형vibration
Microwave

APPLICATIONS FOR ALL INDUSTRIES



QUARRY

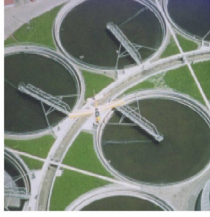

WATER & WASTE



PROCESS



CHEMICAL



MINING

SPECIFICATION

Model reference

Transmitter : HYC-MWS-ST-2-24V
Receiver : HYC-MWS-SR-2-24V

Power supply

Transmitter : 24VDC ± 10%
Receiver : 24VDC ± 10%

Power consumption

Transmitter : 1W, 42mA
Receiver : 2W, 83mA

Operating Range

Maximum 40 metre
(Note : Operating distance may vary depending upon installation).

Frequency & transmission power

Approx. 24GHz, less than 100mW (E.I.R.P.)

Received power level

Indicated by 1 of 15 LED indicators
Note: Indicator is fully illuminated

Sensitivity-set-point

Indicated by 1 of 15 LED indicators
Note: Indicator is half illuminated

Beam angle

Approx. 20 degrees (inclusive angle)

Relay contact

1C(SPDT) relay contact 30VDC, 2A

Response time

10msec.

Adjustable time delay

0.1 ~ 10 sec. adjustable

Delay time from power on to function

Transmitter : Approx. 50msec.
Receiver : Approx. 5sec

Operating ambient temperature

-10°C ~ +55°C

Note : Optional hardware is available for high temperature applications.

Storage ambient temperature

-20°C ~ +70°C

Continuous maximum pressure

5 bar (75psi)

Enclosure rating

IP65 protection

Enclosure construction

Diecast aluminum

Weight

Transmitter : 1kg
Receiver : 1kg

CE Certification Standards

EN300440-2
EN301489-1/3

In accordance with: R & TTE Directive
EMC Directive

TRANSMITTER AND RECEIVER SENSOR DIMENSIONS

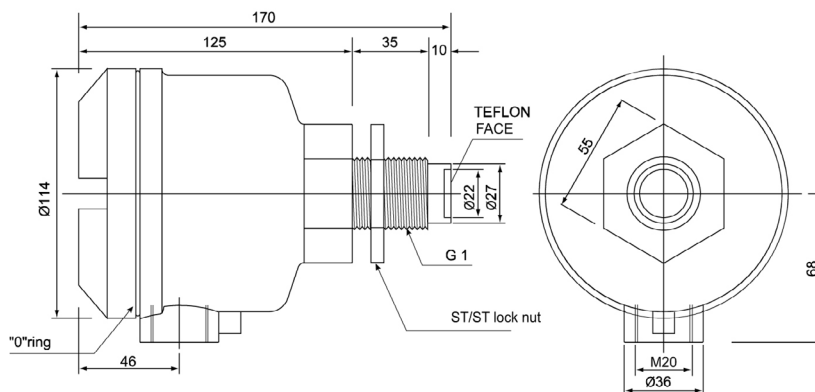

ALIA
MUESEN
SAGE
HYCONTROL
KONICS
WIKA
HBE
서진인스텍
서전발맥
KDI

초음파 레벨계
Microflex C
Miniflex LR
Microflex LR
Reflex LR
레이더 레벨계
Reflex VG5
Reflex VG6
Reflex VG7
Reflex VF3
Reflex VF7
레벨스위치
액체형vibration
분체형vibration
Microwave

Ordering Code

Code	Model		
HYCMWS	MWS Series IP65 Aluminium Enclosure M20 Electrical Entry 1"G Process Connection		
	Code	Switch Type	
	ST-SR2	Transmitter and receiver pair	
	ST-2	Transmitter only	
	SR-2	Receiver only	
	Code	Power Supply & Output	
	24V	24VDC Single SPDT Relay Output CE Approved	
	24VA	110/240VAC Single SPDT Relay Output Non CE Approved. ST-SR2	
	24VA	110/240VAC Single SPDT Relay Output Non CE Approved. DP3	
	Code	Electrical Entries	
	M20	M20	
	5N	1/2"NPT	
	75G	3/4"G	
	Code	Options	
	X	No options required	
	H	145mm Extension Cooling Fins 180°C	
HYC-MWS	χ	χ	χ

ALIA
MUESEN
SAGE
HYCONTROL
KONICS
WIKA
HBE
서진인스텍
서전발맥
KDI

초음파 레벨계
Microflex C
Miniflex LR
Microflex LR
Reflex LR
레이더 레벨계
Reflex VG5
Reflex VG6
Reflex VG7
Reflex VF3
Reflex VF7
레벨스위치
액체형vibration
분체형vibration
Microwave