

## DESIGN FEATURES:

- Steam rating: 150 psi WSP
- Working Pressure: 1/2"~1" 2000 psi  
1 1/4"~2" 1500 psi
- Body: ASTM A351 Gr. CF8M  
ASTM A216 Gr. WCB
- ME-PTFE SEAL KITS: REPLACES PTFE, RPTFE AND FPA  
LOW DEFORMATION UNDER LOAD  
LOW PERMEATION
- TEMPERATURE RATING: -45.5°C (-50°F) to 246°C (475°F)
- LONG CYCLE LIFE
- BLOW - OUT - PROOF STEM
- ANTI - STATIC DEVICE
- ADJUSTABLE STEM PACKING
- HANDLE WITH LOCKING DEVICE
- FULL ISO 5211 PAD FOR DIRECT MOUNT AUTOMATION
- End Connections: Threaded End  
Socket-Weld End
- TEST STANDARD: API 598
- API 607 5<sup>th</sup> Edition FIRE SAFE APPROVAL
- Vacuum Service to 29" Hg

## SERIES FS10



## MATERIALS LIST

NO.	PART NAME	MATERIAL		QTY
		STAINLESS STEEL	CARBON STEEL	
1	BODY	ASTM A351 Gr.CF8M	ASTM A216 WCB	1
2	CAP	ASTM A351 Gr.CF8M	ASTM A216 WCB	2
3	BALL	ASTM A351 Gr.CF8M	ASTM A351 Gr.CF8M	1
4	SEAT	*ME-PTFE	*ME-PTFE	2
5	BOLT	ASTM A193 Gr.B8	ASTM A193 Gr.B7	8
6	GASKET	*ME-PTFE or GRAFOIL	*ME-PTFE or GRAFOIL	2
7	THRUST WASHER	*ME-PTFE or PTFE+50%SS.S.	*ME-PTFE or PTFE+50%SS.S.	1
8	STEM	ASTM A276 Gr.316	ASTM A276 Gr.316	1
9	O-RING	YITON	YITON	1
10	PACKING	*ME-PTFE or GRAFOIL	*ME-PTFE or GRAFOIL	1
11	RING	SS304	SS304	1
12	BELLEVEILLE WASHER	SS410	SS410	2
13	HANDLE NUT	SS304	SS304	2
14	STOP WASHER	SS304	SS304	2
15	STOPPER	SS304	SS304	1
16	LOCKING PLATE	SS304	SS304	1
17	HANDLE	SS304	SS304	1
18	HANDLE SLEEVE	VINYL GRIP	VINYL GRIP	1

\*ME-PTFE IS Molecularly Enhanced PTFE  
 \*For Fire-Safe only

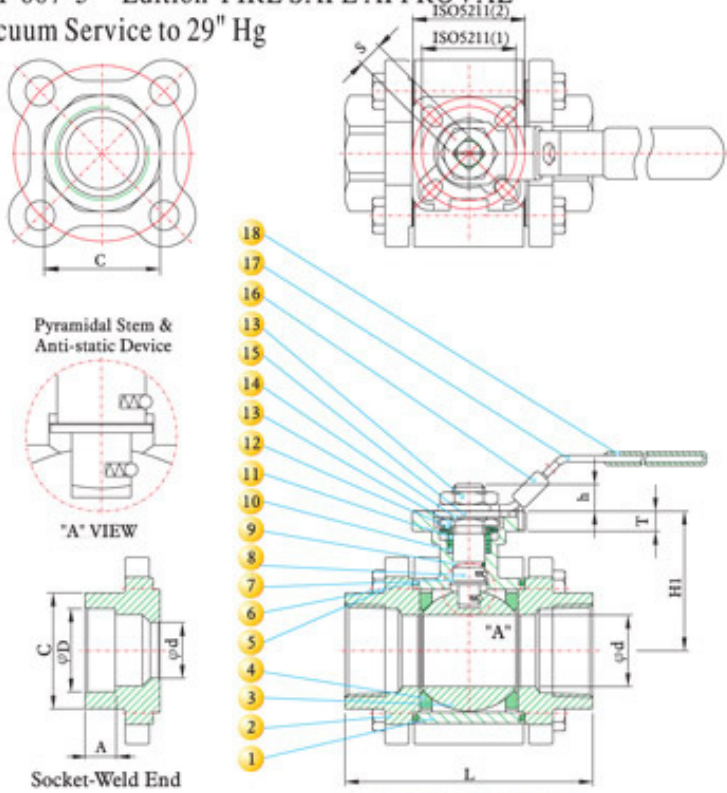

## DIMENSIONS

SIZE	A		C		D		d		L		H1		h		S		T		ISO 5211	Cv Factor	Weight		
	inch	mm	inch	mm	inch	mm	inch	mm	inch	mm	inch	mm	inch	mm	inch	mm	inch	mm			Kg	Lb	
1/2"	15	0.39	10	1.15	29.1	0.85	21.7	0.59	15.0	2.89	73.5	1.67	42.50	0.35	9.0	0.35	9	0.35	9	F03 / F04	26	0.93	2.05
3/4"	20	0.51	13	1.44	36.7	1.07	27.1	0.79	20.0	3.26	83.0	1.83	46.5	0.35	9.0	0.35	9	0.35	9	F03 / F04	55	1.34	2.95
1"	25	0.51	13	1.81	46.0	1.33	33.8	1.00	25.4	3.90	99.0	2.34	59.5	0.45	11.5	0.43	11	0.35	9	F04 / F05	110	2.18	4.80
1 1/4"	32	0.51	13	2.04	51.9	1.68	42.6	1.26	32.0	4.48	114.0	2.46	62.5	0.49	12.5	0.43	11	0.35	9	F04 / F05	180	3.47	7.64
1 1/2"	40	0.51	13	2.33	59.3	1.92	48.7	1.57	40.0	5.03	128.0	3.11	79.0	0.63	16.0	0.55	14	0.51	13	F05 / F07	270	4.73	10.42
2"	50	0.63	16	2.86	72.6	2.41	61.2	2.00	50.8	5.98	152.0	3.42	86.9	0.63	16.0	0.55	14	0.51	13	F05 / F07	500	7.54	16.61

## PRESSURE TEMPERATURE RATINGS

