



VF2 Handbook

Guided Radar (TDR) Level Meter

for distance, level and volume measurement of pastes and solids

All rights reserved. It is prohibited to reproduce this documentation, or any part thereof, without the prior written authorisation of HYCONTROL.

Subject to change without notice.

Copyright 2013 by HYCONTROL

1	Safety instructions	7
<hr/>		
1.1	Software history	7
1.2	Intended use	7
1.3	Certification	8
1.4	Electromagnetic compatibility	8
1.5	Safety instructions from the manufacturer	9
1.5.1	Copyright and data protection	9
1.5.2	Disclaimer	9
1.5.3	Product liability and warranty	10
1.5.4	Information concerning the documentation	10
1.5.5	Warnings and symbols used	11
1.6	Safety instructions for the operator	11
2	Device description	12
<hr/>		
2.1	Scope of delivery	12
2.2	Device description	13
2.3	Visual Check	13
2.4	Nameplates	14
2.4.1	Non-Ex nameplate	14
3	Installation	16
<hr/>		
3.1	General notes on installation	16
3.2	Storage	16
3.3	Transport	17
3.4	Pre-installation requirements	17
3.5	How to prepare the tank before you install the device	18
3.5.1	Pressure and temperature ranges	18
3.5.2	General information for nozzles	19
3.5.3	Installation requirements for concrete roofs	21
3.6	Installation recommendations for liquids	22
3.6.1	General requirements	22
3.6.2	How to attach probes to the bottom of the tank	23
3.6.3	Installation in standpipes (stilling wells and bypass chambers)	26
3.7	Installation recommendations for solids	28
3.7.1	Nozzles on conical silos	28
3.8	How to install the device on the tank	29
3.8.1	How to assemble the single rod probe (single-piece probe)	29
3.8.2	How to assemble the single rod probe (segmented probe)	33
3.8.3	How to assemble the segmented coaxial probe	36
3.8.4	How to install a device with a flange connection	39
3.8.5	How to install a device with a threaded connection	40
3.8.6	How to install a cable probe in the tank	41
3.8.7	Recommendations for pits and tanks made of non-conductive materials	42
3.8.8	How to turn or remove the signal converter	43
3.8.9	How to attach the weather protection to the device	44
3.8.10	How to open the weather protection	46

4	Electrical connections	47
4.1	Safety instructions	47
4.2	Electrical installation: 2-wire, loop-powered	47
4.2.1	Compact version	47
4.2.2	Remote version	49
4.3	Remote device data	50
4.3.1	Requirements for signal cables supplied by the customer	50
4.3.2	How to prepare a signal cable supplied by the customer	51
4.3.3	How to connect the signal cable to the device	52
4.4	Electrical connection for current output	56
4.4.1	Non-Ex devices	56
4.4.2	Devices for hazardous locations	56
4.5	Protection category	56
4.6	Networks	57
4.6.1	General information	57
4.6.2	Point-to-point networks	57
4.6.3	Multi-drop networks	58
4.6.4	Fieldbus networks	59
5	Start-up	61
5.1	How to start the device	61
5.1.1	Start-up checklist	61
5.1.2	How to start the device	61
5.2	Operating concept	61
5.3	Digital display screen	62
5.3.1	Local display screen layout	62
5.3.2	Functions of keypad buttons	63
5.4	Remote communication with PACTware™	64
5.5	Remote communication with the AMS™ Device Manager	65
6	Operation	66
6.1	User modes	66
6.2	Normal mode	66
6.3	Configuration mode	68
6.3.1	General notes	68
6.3.2	How to get access to the commissioning menu	68
6.3.3	Menu overview	69
6.3.4	Keypad functions	70
6.3.5	Function description	73
6.4	Further information on device configuration	79
6.4.1	Quick Setup	79
6.4.2	Test	81
6.4.3	Protection of the device settings	82
6.4.4	HART® network configuration	82
6.4.5	Distance measurement	83
6.4.6	Level measurement	84
6.4.7	How to configure the device to measure volume or mass	84
6.4.8	Thresholds and parasitic signals	86

6.4.9	How to decrease the length of probes.....	88
6.5	Status and error messages.....	90
6.5.1	Device status (markers).....	90
6.5.2	Error handling.....	92
7	Service	96
<hr/>		
7.1	Periodic maintenance.....	96
7.2	Keep the device clean.....	96
7.3	How to replace device components	96
7.3.1	Service warranty	96
7.3.2	Replacement of the VF04 signal converter	96
7.3.3	Replacement of the VF03 signal converter	103
7.3.4	Replacement of the VF7 signal converter	106
7.4	Availability of services	109
7.5	Returning the device to the manufacturer.....	109
7.5.1	General information.....	109
7.5.2	Form (for copying) to accompany a returned device.....	110
7.6	Disposal	110
8	Technical data	111
<hr/>		
8.1	Measuring principle.....	111
8.2	Technical data.....	112
8.3	Minimum power supply voltage	118
8.4	Pressure / flange temperature graph for probe selection.....	119
8.5	Measurement limits	121
8.6	Dimensions and weights	124
9	Description of HART interface	134
<hr/>		
9.1	General description	134
9.2	Software description	134
9.3	Connection variants.....	135
9.3.1	Point-to-Point connection - analogue / digital mode.....	135
9.3.2	Multi-Drop connection (2-wire connection)	135
9.4	HART® device variables	135
9.5	Field Communicator 375/475 (FC 375/475)	136
9.5.1	Installation	136
9.5.2	Operation.....	136
9.6	Asset Management Solutions (AMS)	137
9.6.1	Installation	137
9.6.2	Operation.....	137
9.6.3	Parameter for the basic configuration	137
9.7	Field Device Tool / Device Type Manager (FDT / DTM)	137
9.7.1	Installation	137
9.7.2	Operation.....	137
9.8	Process Device Manager (PDM)	138
9.8.1	Installation	138
9.8.2	Operation.....	138
9.9	HART® menu tree for Basic-DD	139

9.9.1 Overview Basic-DD menu tree (positions in menu tree).....	139
9.9.2 Basic-DD menu tree (details for settings).....	139
9.10 HART® menu tree for AMS.....	141
9.10.1 Overview AMS menu tree (positions in menu tree).....	141
9.10.2 AMS menu tree (details for settings).....	142
9.11 HART® menu tree for PDM	143
9.11.1 Overview PDM menu tree (positions in menu tree).....	143
9.11.2 PDM menu tree (details for settings)	144
10 Appendix	146
<hr/>	
10.1 Order code	146
10.2 Spare parts	152
10.3 Accessories.....	157
10.4 Glossary	158
11 Notes	161
<hr/>	

1.1 Software history

"Firmware revision" agrees with NAMUR NE 53. It is a series of numbers used to record the revision status of embedded software (firmware) in electronic equipment assemblies. It gives data on the type of changes made and the effect that changes have on compatibility.

Data about software revisions is shown in menu 1.1.0 IDENT. For more data, refer to *Function description* on page 73. If it is not possible to refer to the device menu, record the serial number of the device (given on the device nameplate) and speak to the supplier.

Release date	Printed circuit assembly	Firmware revision	Hardware revision	Changes and compatibility	Documentation
2012-06-18	Converter	1.06.02	4000342401k	-	VF2 manual v1
	Sensor	1.21.02	4000357001o		
	HMI (LCD display option)	1.00.02	4000487601m		

1.2 Intended use



CAUTION!

Responsibility for the use of the measuring devices with regard to suitability, intended use and corrosion resistance of the used materials against the measured fluid lies solely with the operator.



INFORMATION!

The manufacturer is not liable for any damage resulting from improper use or use for other than the intended purpose.

This TDR level transmitter measures distance, level, mass and volume of liquids, pastes, slurries, granulates and powders.

It can be installed on tanks, silos and open pits.

1.3 Certification

**DANGER!**

For devices used in hazardous areas, additional safety notes apply; please refer to the Ex documentation.



In accordance with the commitment to customer service and safety, the device described in this document meets the following safety requirements:

- Electromagnetic Compatibility (EMC) Directive 2004/108/EC in conjunction with EN 61326-1 (2006), EN 61326-2-3 (2006). SIL-approved devices agree with EN 61326-3-1 (2008) and EN 61326-3-2 (2008).
- SIL-approved devices agree with EN 61508 (2010).

All devices are based on the CE marking and meet the requirements of NAMUR Guideline NE 21, NE 43, NE 53 and NE 107.

1.4 Electromagnetic compatibility

The device design agrees with European Standard EN 61326-1 when installed in metallic tanks.

You can install the device on open-air tanks and tanks that are not made of metal. Refer also to the note that follows.

**CAUTION!**

If you install a device with a cable probe in a non-metallic tank or open-air pit, a strong electromagnetic field near to the device can have an unwanted effect on the accuracy. Use a device with a coaxial probe for this type of installation.

**INFORMATION!**

Device operation agrees with residential-class (class B) emissions and industrial-class for immunity requirements if:

- *the device has a single or double probe (rod or cable probe) and is used in a closed tank made of metal or*
- *the device has a coaxial probe.*

1.5 Safety instructions from the manufacturer

1.5.1 Copyright and data protection

The contents of this document have been created with great care. Nevertheless, we provide no guarantee that the contents are correct, complete or up-to-date.

The contents and works in this document are subject to copyright. Contributions from third parties are identified as such. Reproduction, processing, dissemination and any type of use beyond what is permitted under copyright requires written authorisation from the respective author and/or the manufacturer.

The manufacturer tries always to observe the copyrights of others, and to draw on works created in-house or works in the public domain.

The collection of personal data (such as names, street addresses or e-mail addresses) in the manufacturer's documents is always on a voluntary basis whenever possible. Whenever feasible, it is always possible to make use of the offerings and services without providing any personal data.

We draw your attention to the fact that data transmission over the Internet (e.g. when communicating by e-mail) may involve gaps in security. It is not possible to protect such data completely against access by third parties.

We hereby expressly prohibit the use of the contact data published as part of our duty to publish an imprint for the purpose of sending us any advertising or informational materials that we have not expressly requested.

1.5.2 Disclaimer

The manufacturer will not be liable for any damage of any kind by using its product, including, but not limited to direct, indirect or incidental and consequential damages.

This disclaimer does not apply in case the manufacturer has acted on purpose or with gross negligence. In the event any applicable law does not allow such limitations on implied warranties or the exclusion of limitation of certain damages, you may, if such law applies to you, not be subject to some or all of the above disclaimer, exclusions or limitations.

Any product purchased from the manufacturer is warranted in accordance with the relevant product documentation and our Terms and Conditions of Sale.

The manufacturer reserves the right to alter the content of its documents, including this disclaimer in any way, at any time, for any reason, without prior notification, and will not be liable in any way for possible consequences of such changes.

1.5.3 Product liability and warranty

The operator shall bear responsibility for the suitability of the device for the specific purpose. The manufacturer accepts no liability for the consequences of misuse by the operator. Improper installation and operation of the devices (systems) will cause the warranty to be void. The respective "Standard Terms and Conditions" which form the basis for the sales contract shall also apply.

1.5.4 Information concerning the documentation

To prevent any injury to the user or damage to the device it is essential that you read the information in this document and observe applicable national standards, safety requirements and accident prevention regulations.

If this document is not in your native language and if you have any problems understanding the text, we advise you to contact your local office for assistance. The manufacturer can not accept responsibility for any damage or injury caused by misunderstanding of the information in this document.

This document is provided to help you establish operating conditions, which will permit safe and efficient use of this device. Special considerations and precautions are also described in the document, which appear in the form of underneath icons.

1.5.5 Warnings and symbols used

Safety warnings are indicated by the following symbols.



DANGER!

This information refers to the immediate danger when working with electricity.



DANGER!

This warning refers to the immediate danger of burns caused by heat or hot surfaces.



DANGER!

This warning refers to the immediate danger when using this device in a hazardous atmosphere.



DANGER!

These warnings must be observed without fail. Even partial disregard of this warning can lead to serious health problems and even death. There is also the risk of seriously damaging the device or parts of the operator's plant.



WARNING!

Disregarding this safety warning, even if only in part, poses the risk of serious health problems. There is also the risk of damaging the device or parts of the operator's plant.



CAUTION!

Disregarding these instructions can result in damage to the device or to parts of the operator's plant.



INFORMATION!

These instructions contain important information for the handling of the device.



LEGAL NOTICE!

This note contains information on statutory directives and standards.



• **HANDLING**

This symbol designates all instructions for actions to be carried out by the operator in the specified sequence.

➔ **RESULT**

This symbol refers to all important consequences of the previous actions.

1.6 Safety instructions for the operator



WARNING!

*In general, devices from the manufacturer may only be installed, commissioned, operated and maintained by properly trained and authorized personnel.
This document is provided to help you establish operating conditions, which will permit safe and efficient use of this device.*

2.1 Scope of delivery



INFORMATION!

Do a check of the packing list to make sure that you have all the elements given in the order.

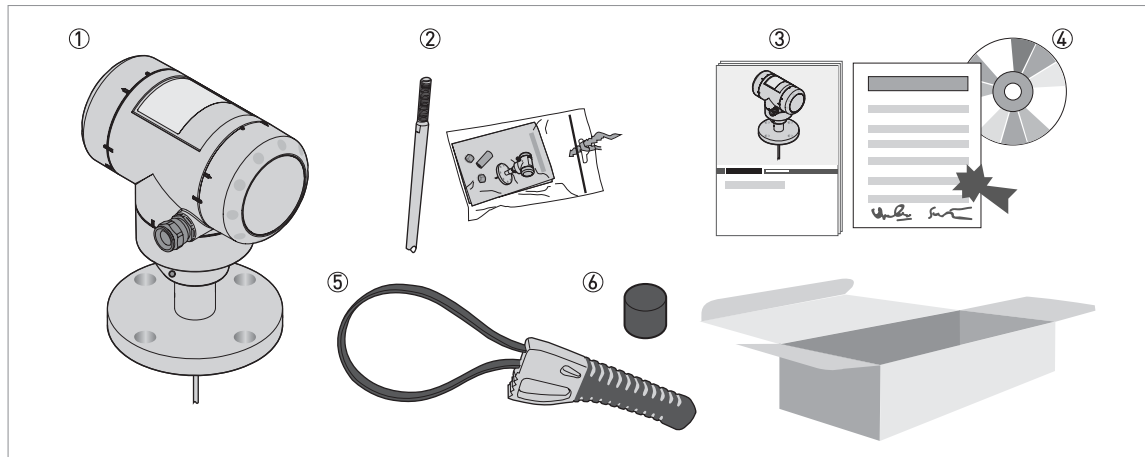

Figure 2-1: Scope of delivery

- ① Signal converter and probe.
- ② Probe segments. For the assembly procedure of the single rod probe, refer to *How to assemble the single rod probe (single-piece probe)* on page 29. If a single rod or coaxial probe is attached and you ordered the "segmented probe" option, only part of the probe is attached to the device. For the assembly procedure of the segmented single rod probe, refer to *How to assemble the single rod probe (segmented probe)* on page 33. For the assembly procedure of the segmented coaxial probe, refer to *How to assemble the segmented coaxial probe* on page 36.
- ③ Quick Start
- ④ DVD-ROM. This contains the Handbook, the Quick Start, the Technical Datasheet and related software.
- ⑤ Strap wrench
- ⑥ Probe assembly cover



INFORMATION!

No training required!



Figure 2-3: Symbols for the supplied gasket material (on the side of the process connection)

- ① EPDM
- ② Kalrez® 6375

If the device is supplied with an FKM/FPM gasket, there is no symbol on the side of the process connection.

2.4 Nameplates



INFORMATION!

Look at the device nameplate to ensure that the device is delivered according to your order. Check for the correct supply voltage printed on the nameplate.

2.4.1 Non-Ex nameplate

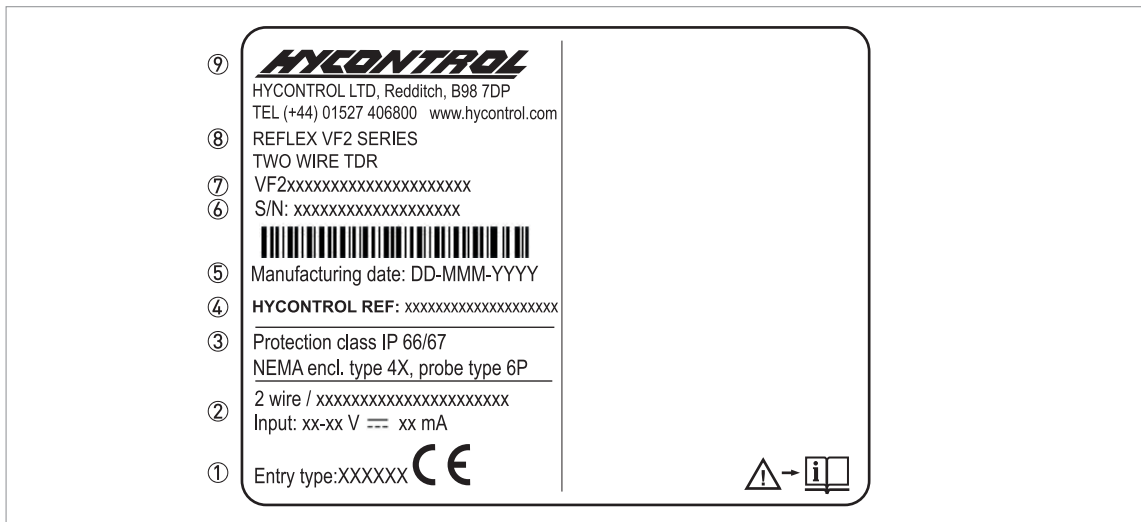

Figure 2-4: Compact and remote versions: Non-Ex nameplate attached to the housing

- ① Cable entry size
- ② Communication protocol (analog, digital, fieldbus, ...), input voltage and maximum current (fieldbus options: basic current)
- ③ Degree of ingress protection (according to EN 60529 / IEC 60529)
- ④ Hycontrol reference code
- ⑤ Date of manufacture
- ⑥ Order number
- ⑦ Type code (defined in order)
- ⑧ Model name and number
- ⑨ Company name and address

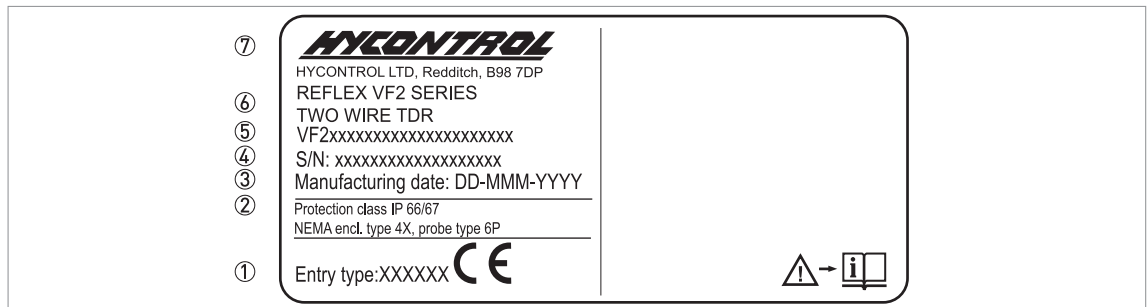

Figure 2-5: Remote version: Non-Ex nameplate attached to the probe assembly

- ① Cable entry size
- ② Degree of ingress protection (according to EN 60529 / IEC 60529)
- ③ Date of manufacture
- ④ Order number
- ⑤ Type code (defined in order)
- ⑥ Model name and number
- ⑦ Company name and address

3.1 General notes on installation



INFORMATION!

Inspect the cartons carefully for damages or signs of rough handling. Report damage to the carrier and to the local office of the manufacturer.



INFORMATION!

Do a check of the packing list to make sure that you have all the elements given in the order.



INFORMATION!

Look at the device nameplate to ensure that the device is delivered according to your order. Check for the correct supply voltage printed on the nameplate.

3.2 Storage



WARNING!

Do not keep the device in a vertical position. This will damage the probe and the device will not measure correctly.

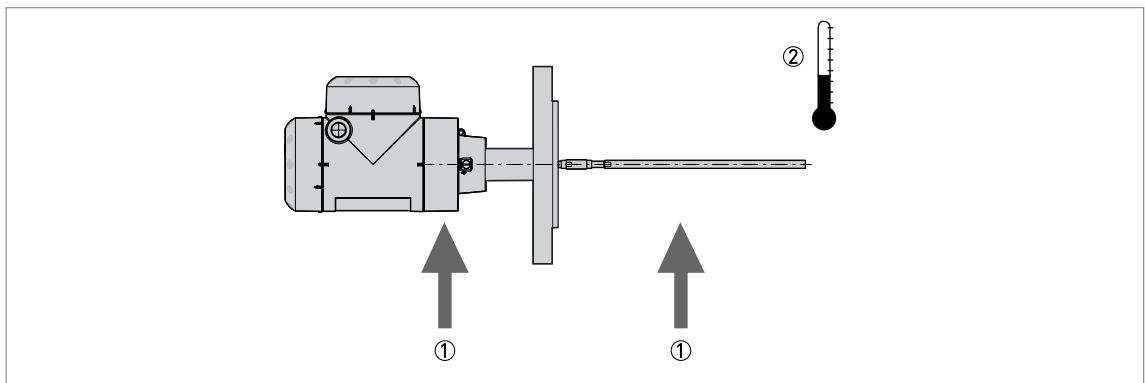

Figure 3-1: Storage conditions

- ① Do not bend rod and coaxial probes - support here
- ② Storage temperature range: -50...+85°C / -60...+185°F [min. -40°C / -40°F for devices with the integrated LCD display option]

- Store the device in a dry and dust-free location.
- Store the device in its original packing.

3.3 Transport

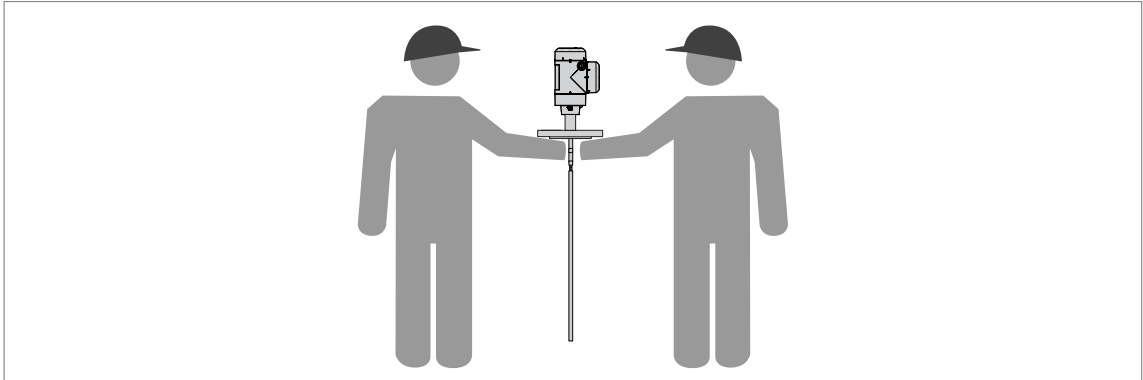

Figure 3-2: How to hold the device

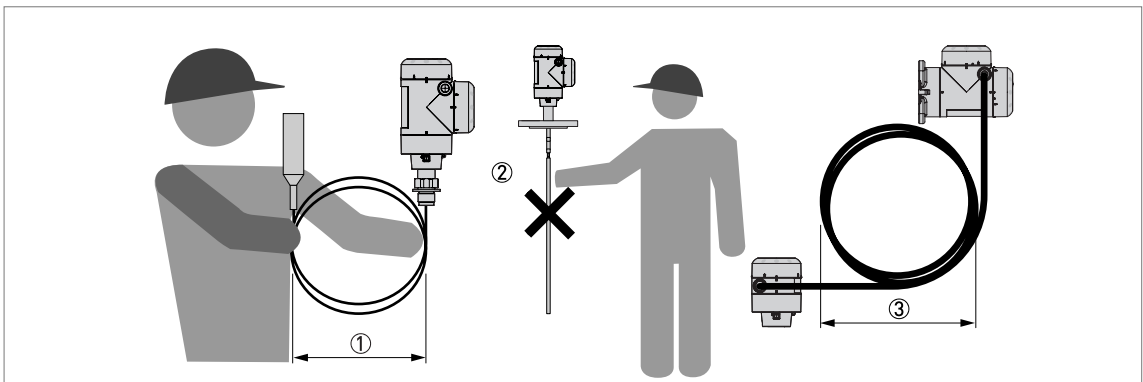

Figure 3-3: How to hold the device

- ① Wind cable probes greater than 400 mm / 16" in diameter.
- ② Do not hold the probe when you lift the device.
- ③ Do not wind the electrical cable less than 330 mm / 13" in diameter.



WARNING!

If you do not lift the device carefully, you can cause damage to the probe.

3.4 Pre-installation requirements



INFORMATION!

Obey the precautions that follow to make sure that the device is correctly installed.

- Make sure that there is sufficient space on all sides.
- Protect the signal converter from direct sunlight.
- Do not subject the signal converter to heavy vibrations.

3.5 How to prepare the tank before you install the device



CAUTION!

To avoid measuring errors and device malfunction, obey these precautions.

3.5.1 Pressure and temperature ranges

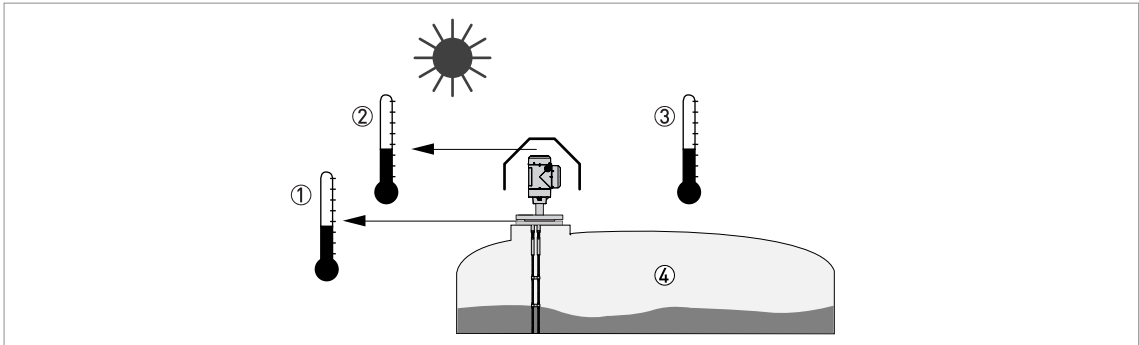

Figure 3-4: Pressure and temperature ranges

- ① Temperature at the process connection
The temperature at the process connection must stay in the temperature range of the gasket material unless the device is a High-Temperature version. Refer to the table "Permitted temperature ranges for gaskets" that follows and to "Technical data" on page 112.
Devices with Hazardous Location approvals: see supplementary instructions
- ② Ambient temperature for operation of the display
-20...+60°C / -4...+140°F
If the ambient temperature is not between these limits, the display screen switches off automatically
- ③ Ambient temperature
Non-Ex devices: -40...80°C / -40...176°F
Devices with Hazardous Location approvals: see supplementary instructions
- ④ Process pressure
-1...40 barg / -14.5...580 psig



WARNING!

The process connection temperature range must agree with the temperature limits of the gasket material.

Permitted temperature ranges for gaskets

Gasket material	Permitted temperature ranges for gaskets			
	Standard version		High-Temperature version	
	[°C]	[°F]	[°C]	[°F]
FKM/FPM	-40...+150	-40...+302	-40...+300	-40...+572
Kalrez® 6375	-20...+150	-4...+302	-20...+300	-4...+572
EPDM	-50...+150	-58...+302	-50...+250	-58...+482

3.5.2 General information for nozzles



CAUTION!

Follow these recommendations to make sure that the device measures correctly.



CAUTION!

Do not put the process connection near to the product inlet. If the product that enters the tank touches the probe, the device will measure incorrectly.

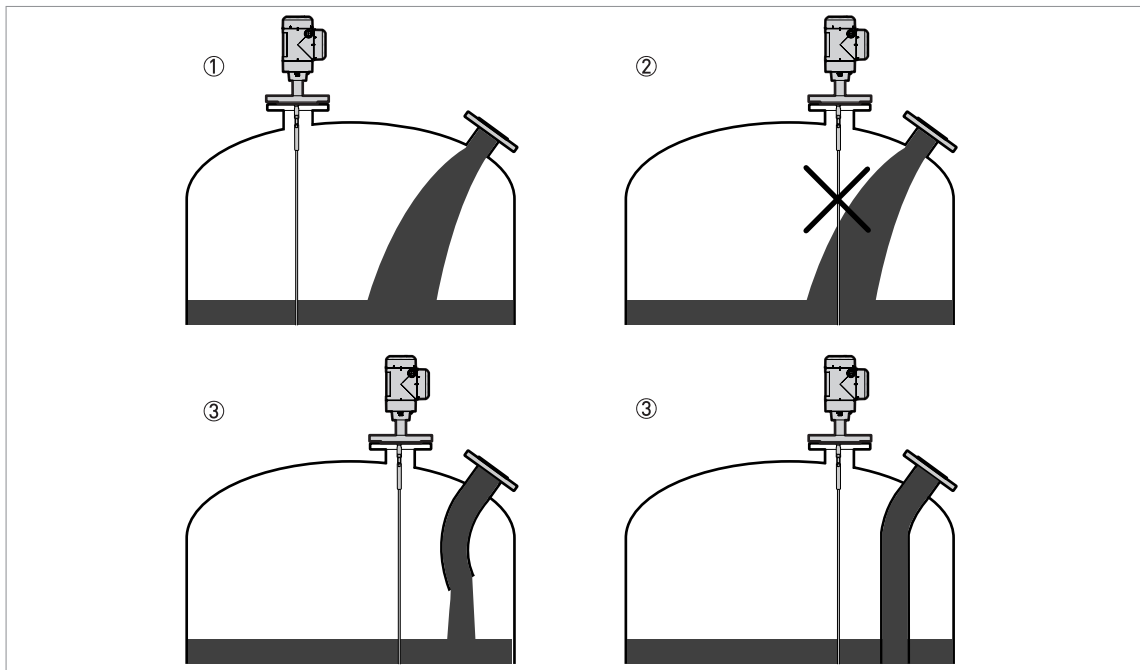

Figure 3-5: Do not put the device near to a product inlet

- ① The device is in the correct position.
- ② The device is too near to the product inlet.
- ③ If it is not possible to put the device in the recommended position, install a deflector pipe.

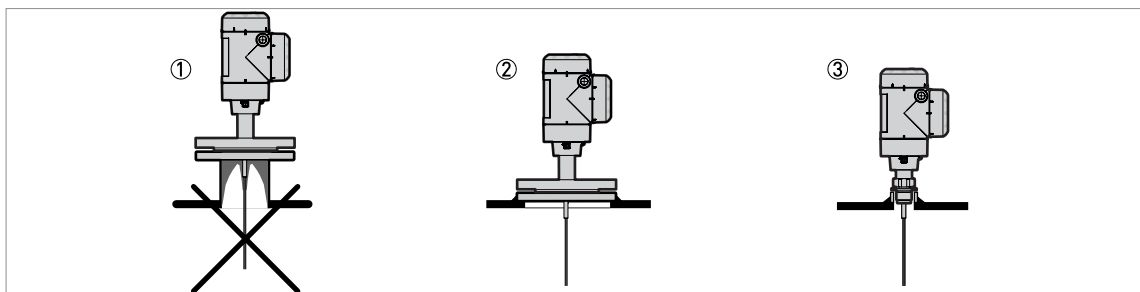

Figure 3-6: How to prevent build up of product around the process connection

- ① If product particles are likely to collect in holes, a nozzle is not recommended.
- ② Attach the flange directly to the tank.
- ③ Use a threaded connection to attach the device directly to the tank.

For single cable and single rod probes:

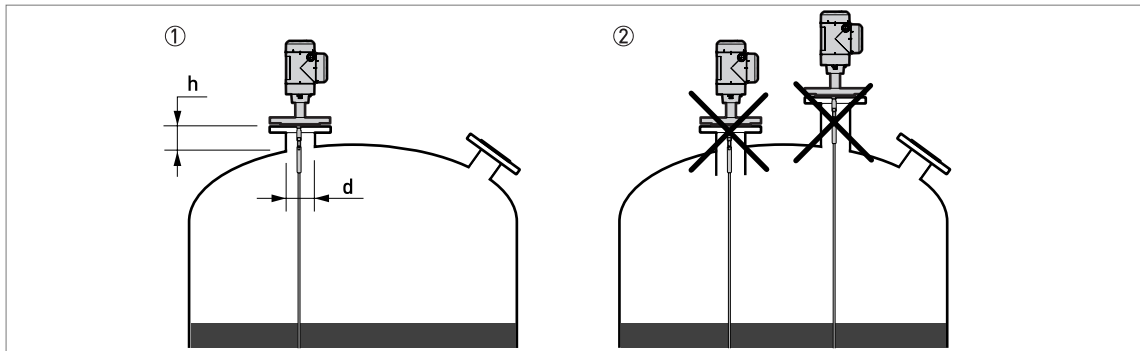

Figure 3-7: Recommended nozzle dimensions for single rod and single cable probes

- ① Recommended conditions: $h \leq d$, where h is the height of the tank nozzle and d is the diameter of the tank nozzle.
- ② The end of the nozzle must not have an extension into the tank. Do not install the device on a high nozzle.



CAUTION!

If the device is installed on a high nozzle, make sure that the probe does not touch the side of the nozzle (attach the probe end, ...).

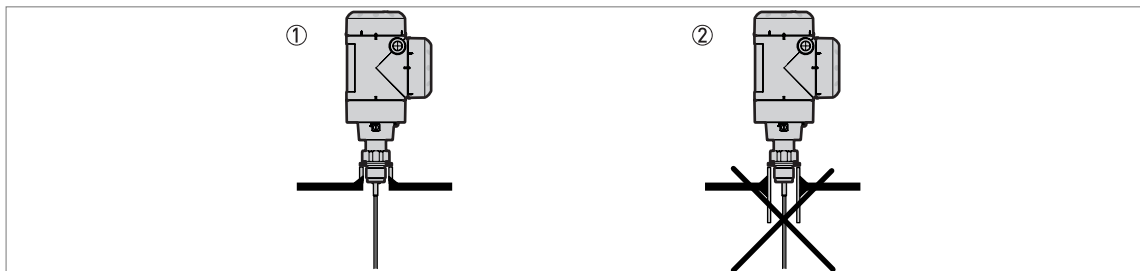

Figure 3-8: Sockets for threaded process connections

- ① Recommended installation
- ② The end of the socket must not have an extension into the tank

For double cable and double rod probes:

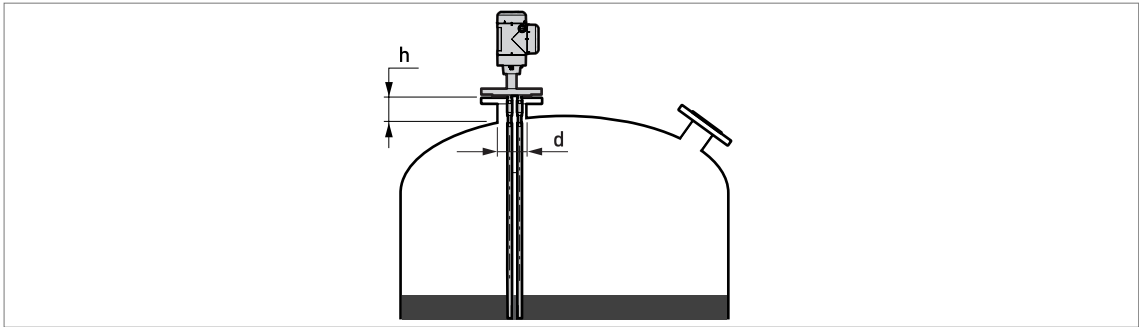

Figure 3-9: Recommended nozzle dimensions for double rod and double cable probes
 $d \geq 50 \text{ mm} / 2''$, where d is the diameter of the tank nozzle

For coaxial probes:

If your device has a coaxial probe, you can ignore these installation recommendations.



CAUTION!

Install coaxial probes in clean liquids that are not too viscous.

3.5.3 Installation requirements for concrete roofs

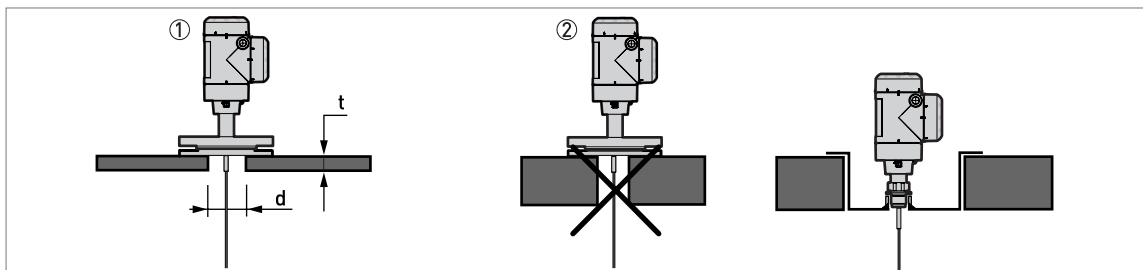

Figure 3-10: Installation on a concrete roof

- ① The diameter, d , of the hole must be greater than the thickness, t , of the concrete.
- ② If the thickness, t , of the concrete is greater than the diameter, d , of the hole, install the device in a recess.

3.6 Installation recommendations for liquids

3.6.1 General requirements

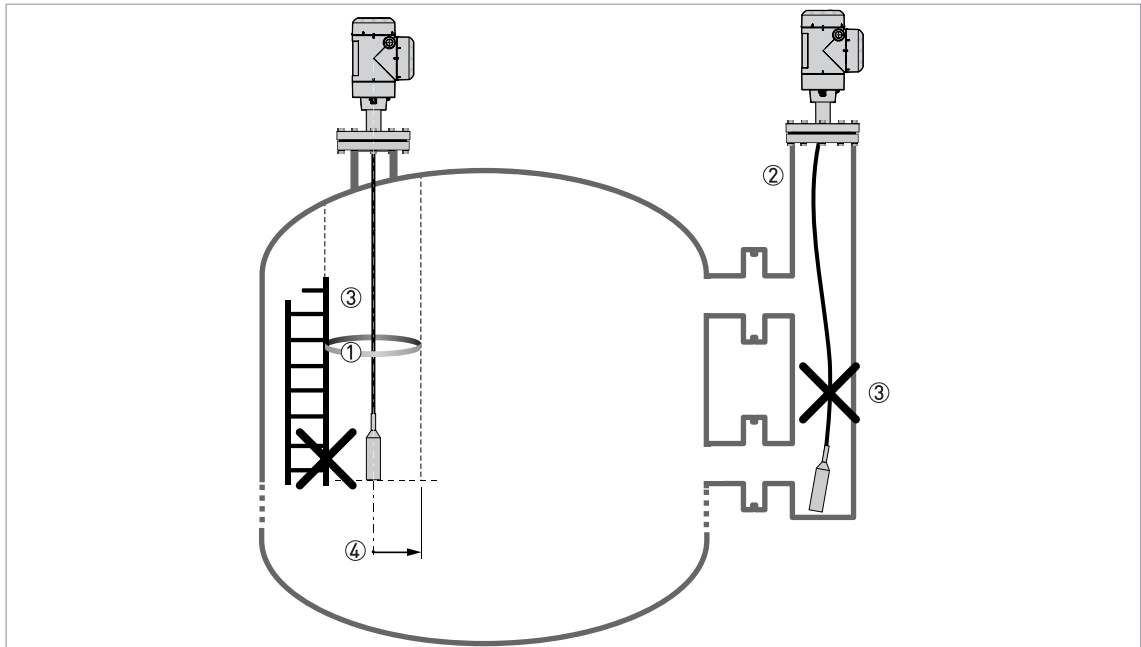

Figure 3-11: Installation recommendations for liquids

- ① The electromagnetic (EM) field generated by the device. It has a radius of R_{min} . Make sure that the EM field is clear of objects and product flow. Refer to the table that follows.
- ② If there are too many objects in the tank, install a bypass chamber or stilling well.
- ③ Keep the probe straight. If the probe is too long, shorten the probe length. Make sure that the device is configured with the new probe length. For more data on the procedure, refer to *How to decrease the length of probes* on page 88.
- ④ Empty space. Refer to the table that follows.

Clearance between the probe and other objects in the tank

Probe type	Empty space (radius, R_{min}), around the probe	
	[mm]	[inches]
Coaxial	0	0
Double rod / cable	100	4
Single rod / cable	300	12

3.6.2 How to attach probes to the bottom of the tank

If the liquid is agitated or turbulent, you can attach the probe to the bottom of the tank. The procedure to attach the probe depends on the type of probe used.



CAUTION!
Keep the probe straight.

Double rod $\varnothing 8$ mm / 0.3"

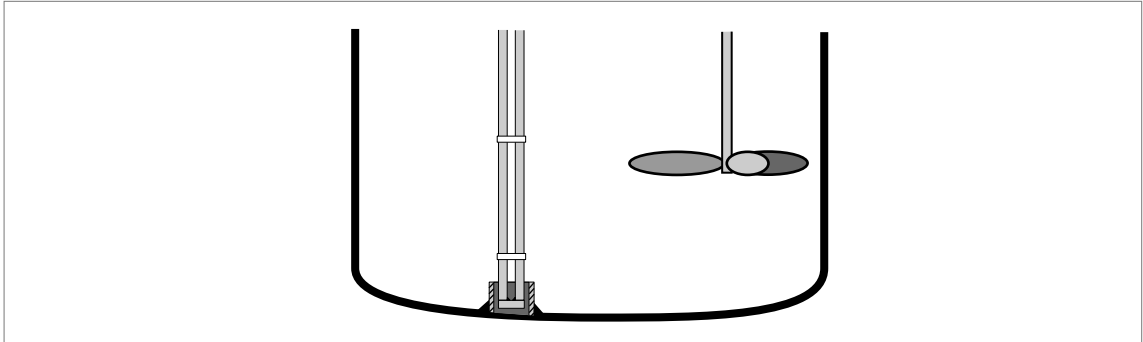

Figure 3-12: How to attach a double rod probe to keep it straight



- Weld a tube with an internal diameter of 28...30 mm / 1.1...1.2" to the bottom of the tank.
- Make sure the tube aligns with the process connection at the top of the tank.
- Lower the probe into the tank.
- Put the end of the probe into the tube.

Double cable $\varnothing 4$ mm / 0.15"

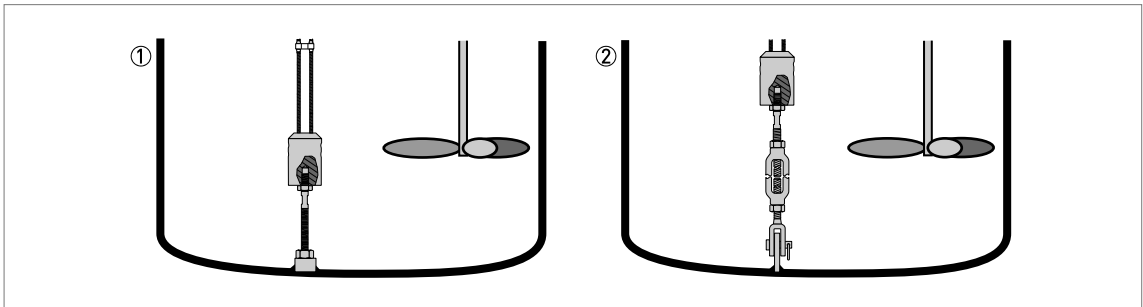

Figure 3-13: How to attach a double cable probe to keep it straight



The probe counterweight has a hole with an M8 internal thread. You can also select the appropriate options and attach:

- ① An anchoring rod
- ② A turnbuckle

For more data, contact your supplier.

Single rod $\varnothing 8$ mm / 0.3"

Figure 3-14: How to attach a single rod probe to keep it straight



- Weld a tube with an internal diameter of 12 mm / 0.5" to the bottom of the tank.
- Make sure the tube aligns with the process connection at the top of the tank.
- Lower the probe into the tank.
- Put the end of the probe into the tube.

Single cable $\varnothing 4$ mm / 0.15"Figure 3-15: How to attach a $\varnothing 4$ mm / 0.15" single cable probe to keep it straight

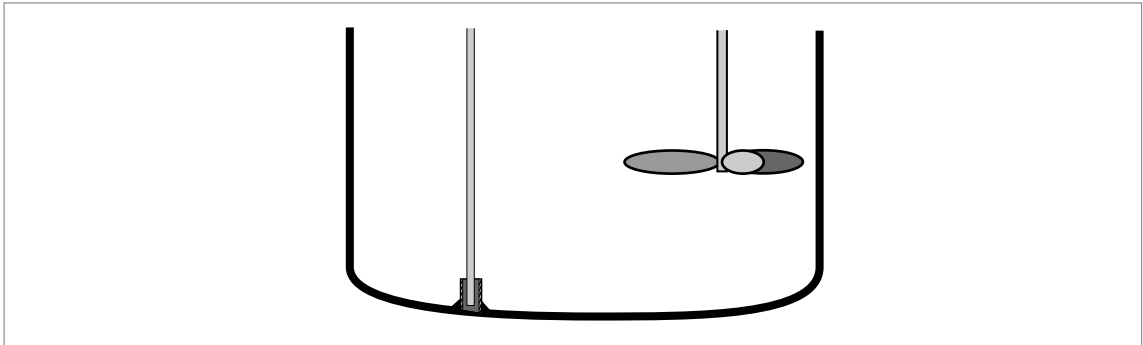
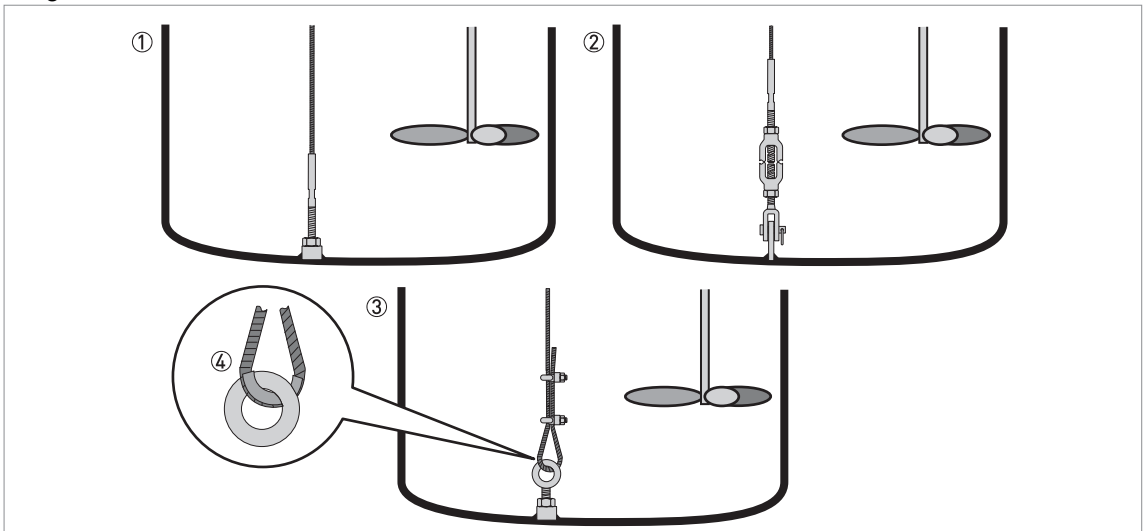
- ① Probe with threaded end
- ② Probe with turnbuckle
- ③ Probe with chuck
- ④ If you chose a chuck to anchor the probe, we recommend that you fit a ferrule (metal sheath - not supplied) at the bottom of the loop to prevent cable wear

The probe counterweight has a hole with an M8 internal thread. The other probe end options are given in the illustration.

**CAUTION!**

If your device has a chuck, you must recalculate the probe length. For the procedure, refer to How to decrease the length of probes on page 88. If the device is not set to the correct probe length, it is possible that the device will not measure correctly.

Single cable $\varnothing 2$ mm / 0.08"

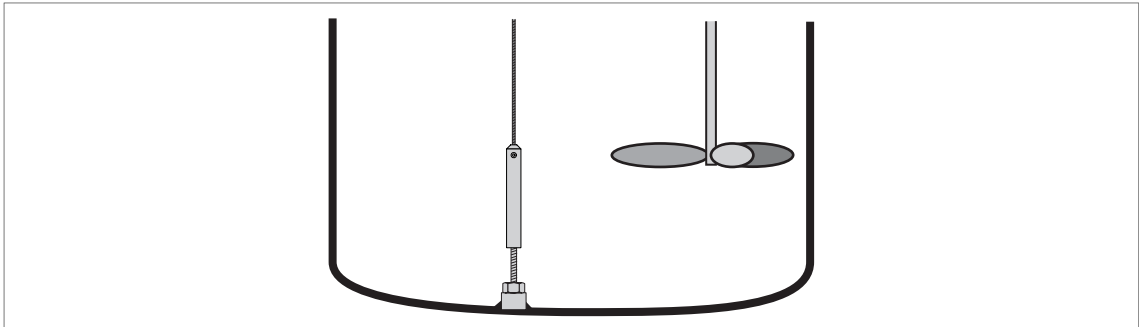

Figure 3-16: How to attach a $\varnothing 2$ mm / 0.08" single cable probe to keep it straight

The probe counterweight has a hole with an M8 internal thread. You can attach the probe counterweight to a threaded end.

Coaxial $\varnothing 22$ mm / 0.8"

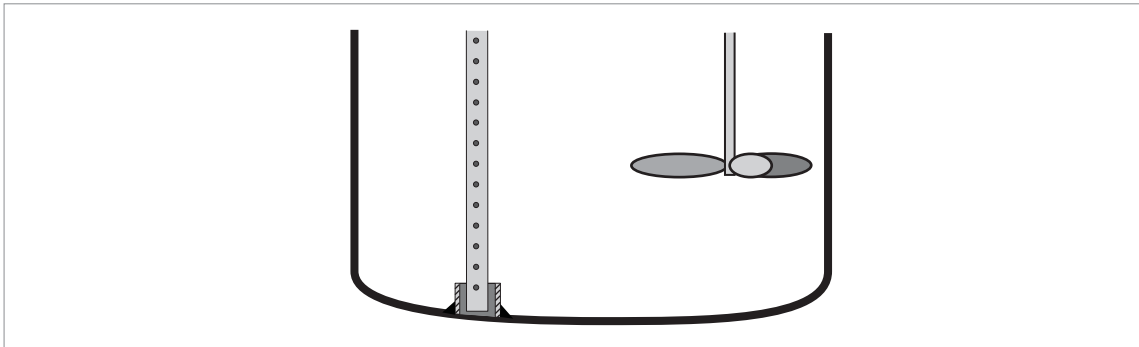

Figure 3-17: How to attach a coaxial probe to keep it straight



- Weld a tube with an internal diameter of 23...25 mm / 0.91...1" to the bottom of the tank.
- ➡ Make sure the tube aligns with the process connection at the top of the tank.
- Lower the probe into the tank.
- Put the end of the probe into the tube.

If this is not possible, you can attach braces to the probe.

3.6.3 Installation in standpipes (stilling wells and bypass chambers)

Use a standpipe if:

- The liquid is very turbulent or agitated.
- There are too many other objects in the tank.
- The device is measuring a liquid in a tank with a floating roof.

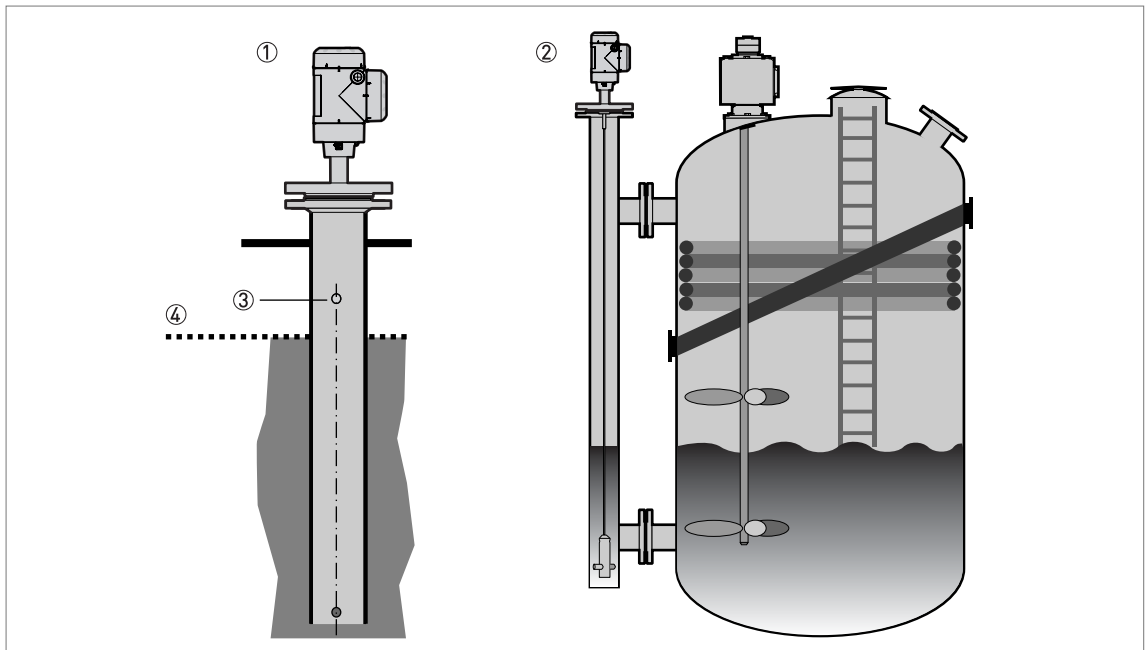

Figure 3-18: Installation recommendations for standpipes (stilling wells and bypass chambers)

- ① Stilling well
- ② Bypass chamber
- ③ Vent
- ④ Level of the liquid



INFORMATION!

Stilling wells are not necessary for devices with coaxial probes. But if there is a sudden change in diameter in the stilling well, we recommend that you install a device with a coaxial probe.

**CAUTION!****Installation requirements**

- The standpipe must be electrically conductive. If the standpipe is not made of metal, obey the instructions for empty space around the probe. For more data, refer to General requirements on page 22.
- The standpipe must be straight. There must be no changes in diameter from the device process connection to the bottom of the standpipe.
- The standpipe must be vertical.
- Recommended surface roughness: $< \pm 0.1 \text{ mm} / 0.004''$.
- The bottom of the stilling well must be open.
- Adjust the probe to the center of the standpipe.
- Make sure that there are no deposits at the bottom of the standpipe which can cause blockage of the process connections.
- Make sure that there is liquid in the standpipe.

Floating roofs

If the device is for a tank with a floating roof, install it in a stilling well.

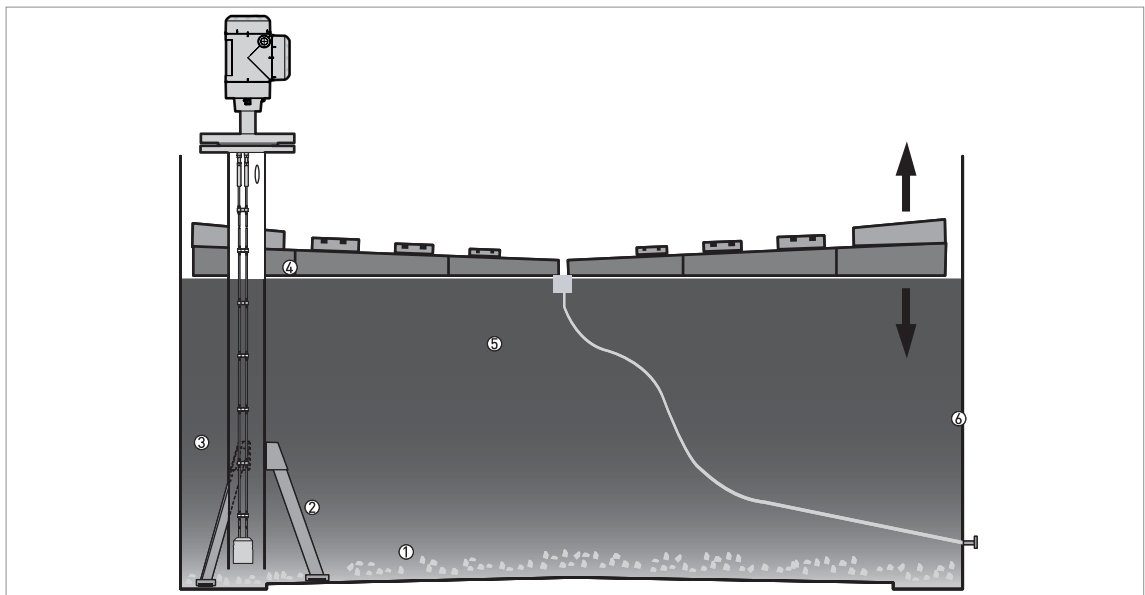

Figure 3-19: Floating roofs

- ① Sediment
- ② Support fixtures
- ③ Stilling well
- ④ Floating roof
- ⑤ Product
- ⑥ Tank

3.7 Installation recommendations for solids

3.7.1 Nozzles on conical silos

We recommend that you prepare the installation when the silo is empty.



DANGER!

Risk of electrostatic discharge (ESD): The device is resistant to electrostatic discharges of up to 30 kV, but it is the responsibility of the fitter and the user to prevent ESD.



CAUTION!

Install the device at the correct location to measure level correctly and prevent too much bending and traction. If necessary, attach the probe to the bottom of the tank.

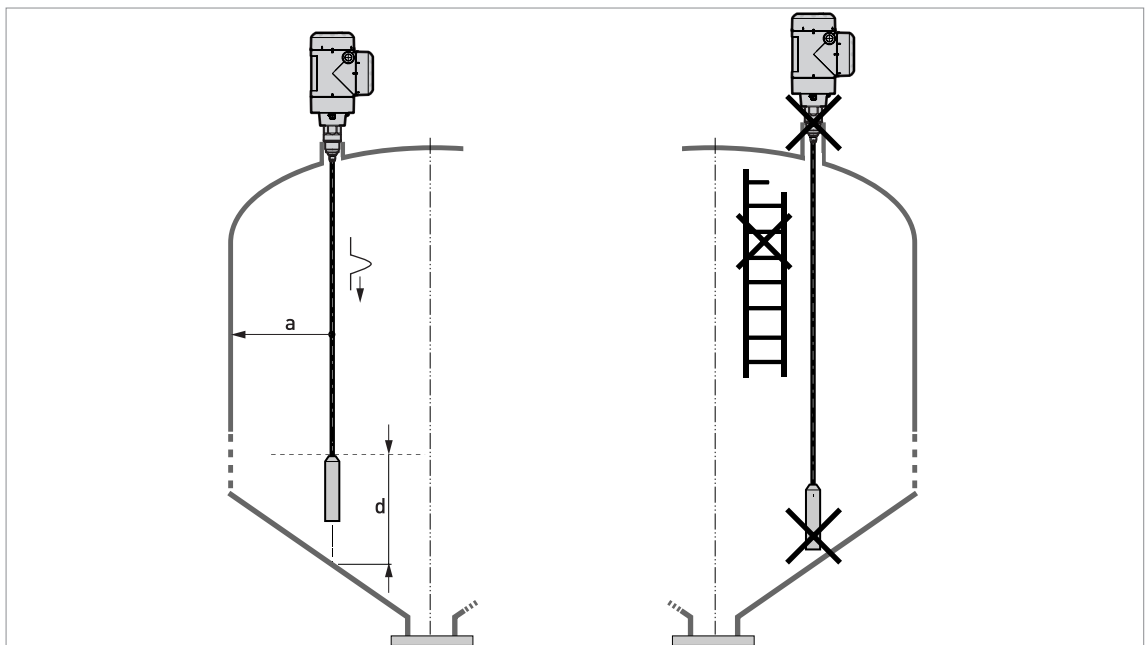

Figure 3-20: Installation recommendations for solids

$a \geq 300 \text{ mm} / 12''$

$d \geq 300 \text{ mm} / 12''$

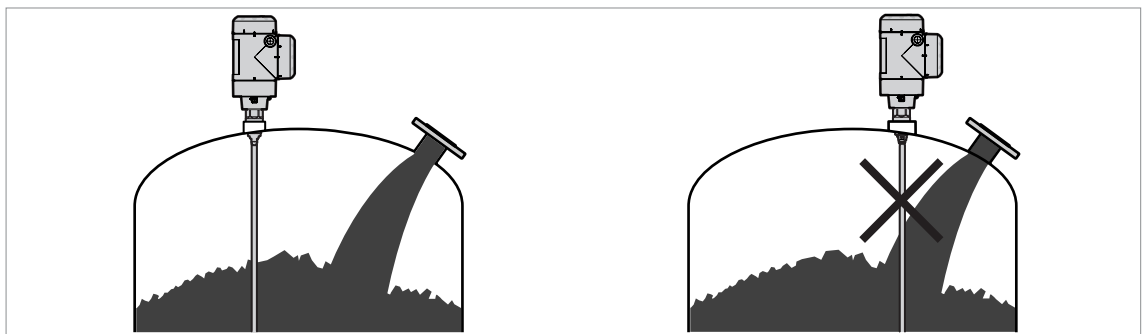

Figure 3-21: Do not install the probe near to a product inlet

3.8 How to install the device on the tank

3.8.1 How to assemble the single rod probe (single-piece probe)

**INFORMATION!**

This procedure is for devices with single rod probes that are not segmented (single-piece probes).

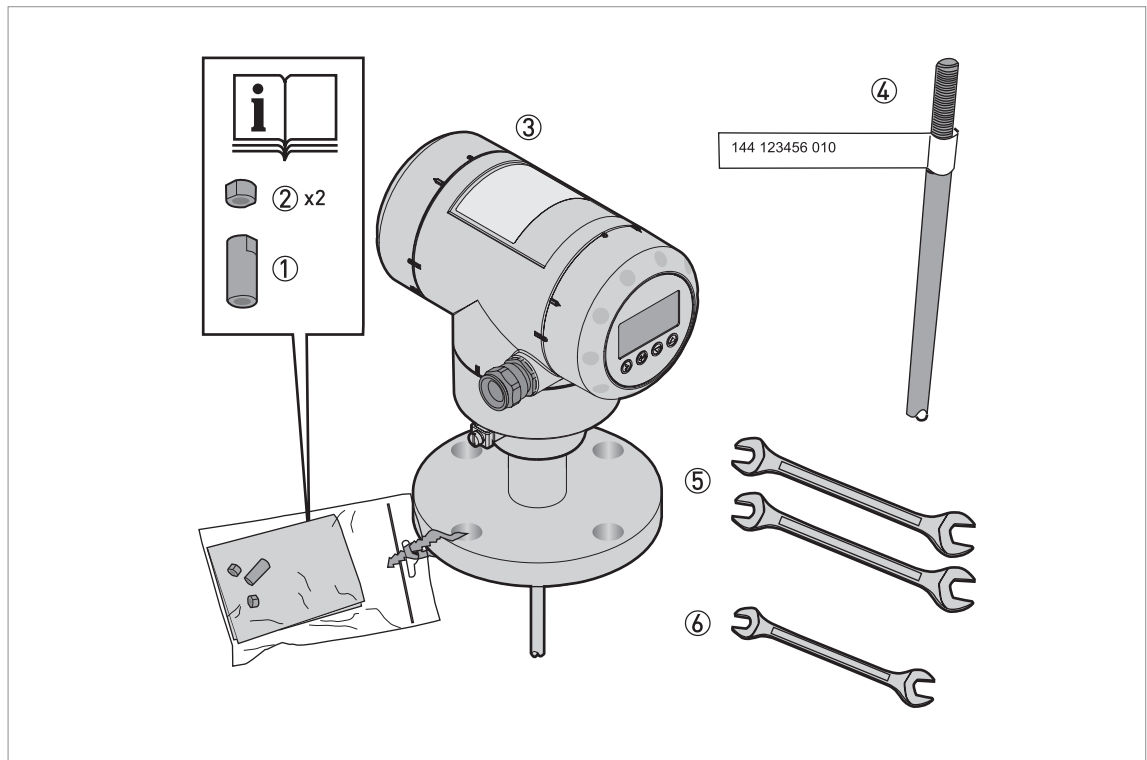

Figure 3-22: Equipment needed to assemble the device

- ① Union nut
- ② 2 locking nuts
- ③ Housing assembly
- ④ Single rod probe
- ⑤ Tools: two 8 mm open-ended wrenches (not supplied)
- ⑥ Tools: one 7 mm open-ended wrench (not supplied)

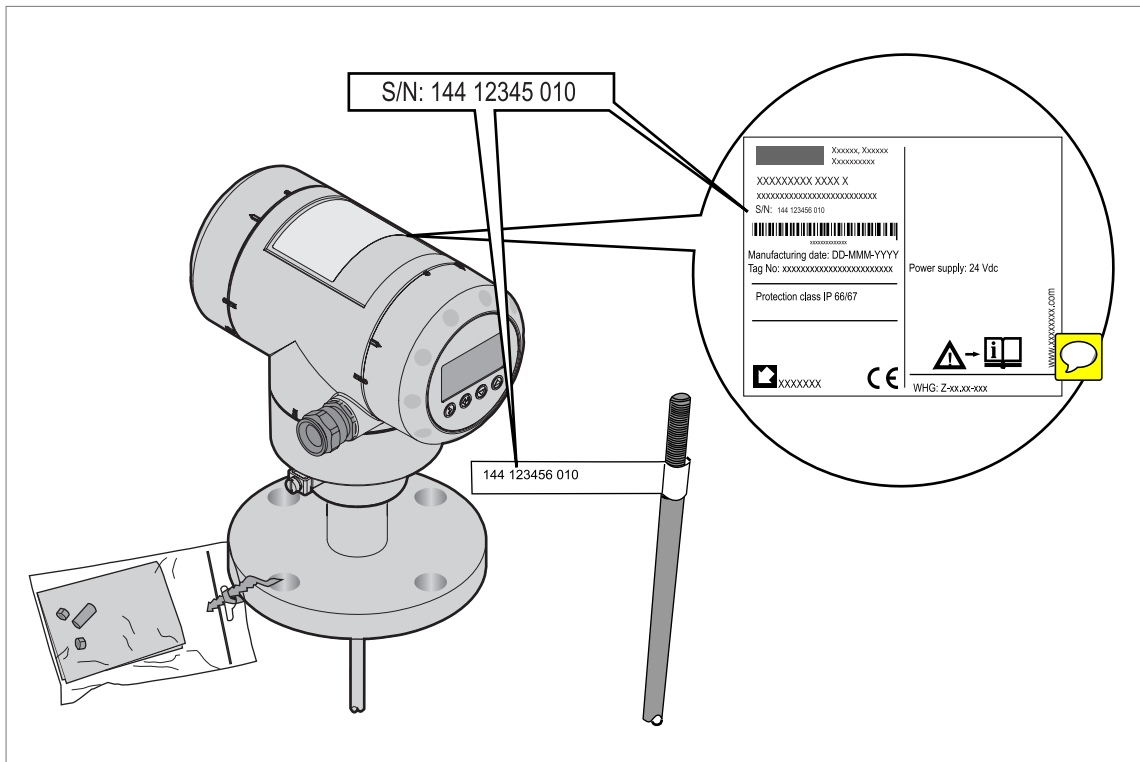

Figure 3-23: Check the order number on each component



- Make sure that the housing assembly and the single rod have the same ID numbers.
- Remove the sticker from the probe.

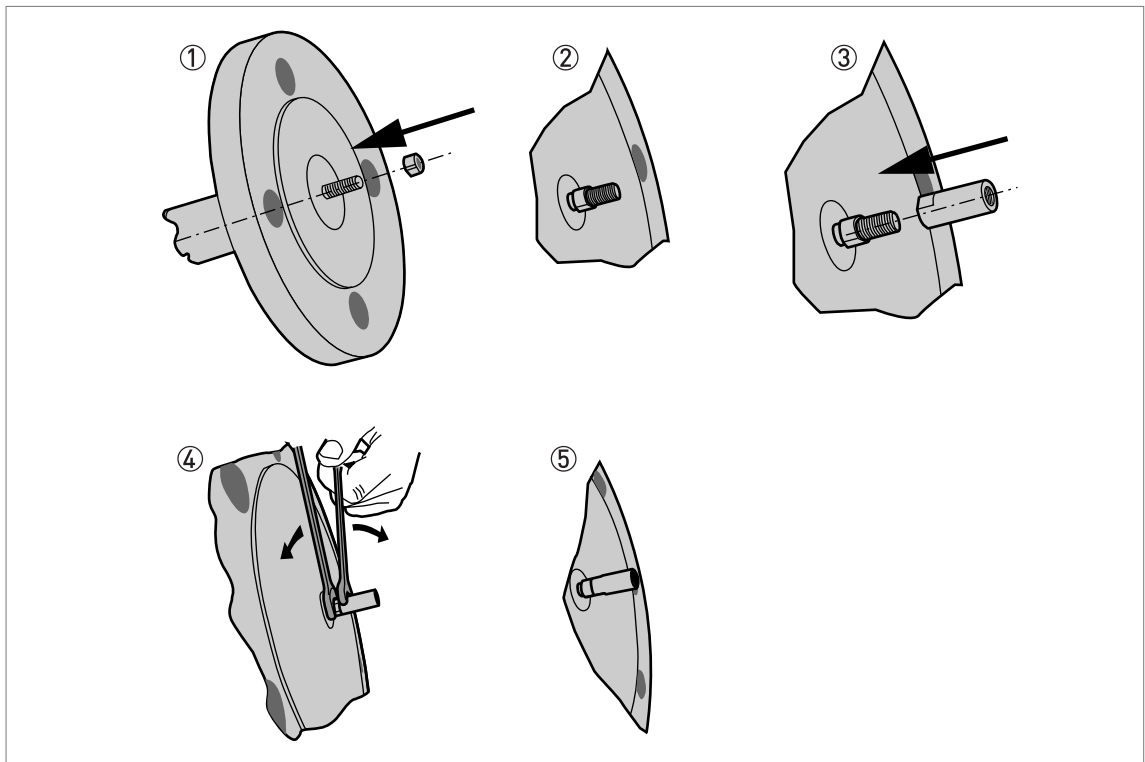

Figure 3-24: How to attach the locking nut and union nut



- Attach a locking nut to the housing assembly.
- Make sure that the nut is fully engaged on the thread.
- Attach the union nut to the housing assembly.
- Tighten these nuts with the two 8 mm open-ended wrenches.
- Continue the assembly procedure on the page that follows.

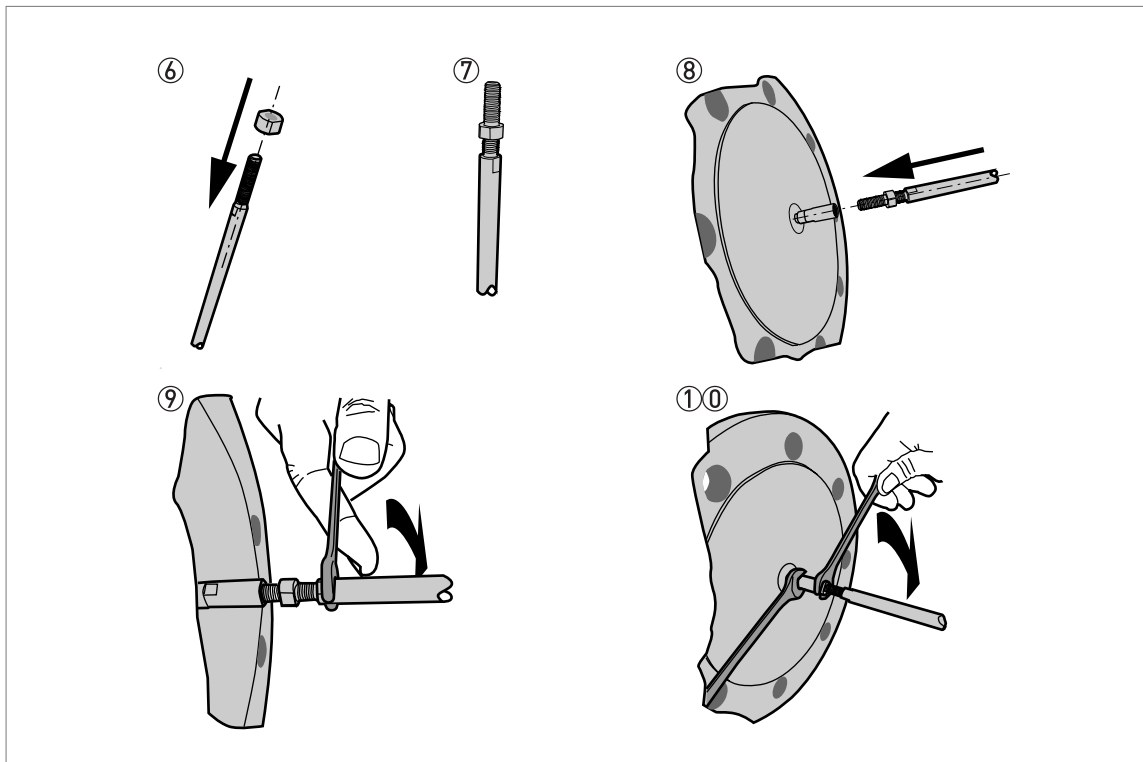

Figure 3-25: How to attach the single rod probe to the flange assembly



CAUTION!

Support the probe.



- Attach a locking nut to the single rod.
- Make sure that the locking nut is engaged $\frac{3}{4}$ along the length of the thread.
- Attach the single rod to the union nut. Make sure the probe touches the housing assembly.
- Tighten the single probe with a 7 mm open-ended wrench (step 9).
- Tighten the locking nut against the union nut with two 8 mm open-ended wrenches (step 10).

3.8.2 How to assemble the single rod probe (segmented probe)



INFORMATION!

This procedure is for devices with single rod probes that are segmented.

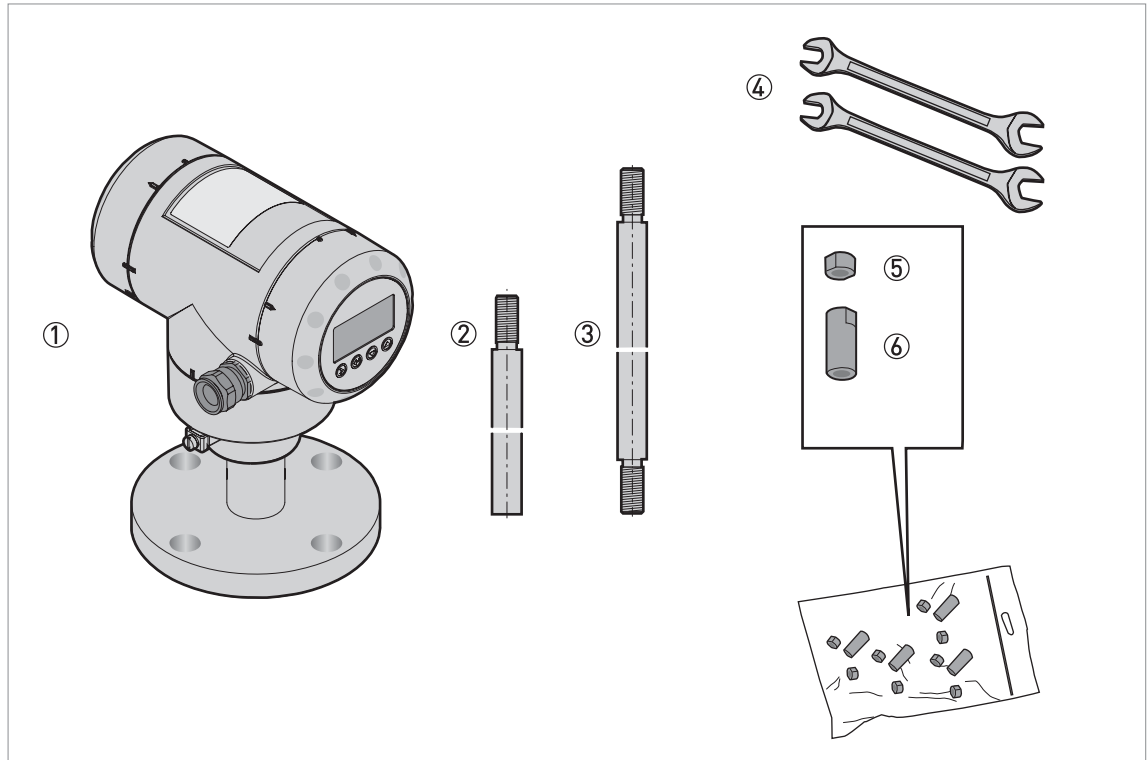

Figure 3-26: Equipment needed to assemble the single rod probe (segmented)

- ① Converter and process connection
- ② Bottom (quantity: 1) segment of the rod probe
- ③ Top and middle (if more than one) segments of the rod probe
- ④ Tools: two 8 mm open-end wrenches (not supplied)
- ⑤ Lock nuts (2 lock nuts per segment)
- ⑥ Union nut (1 union nut per segment)

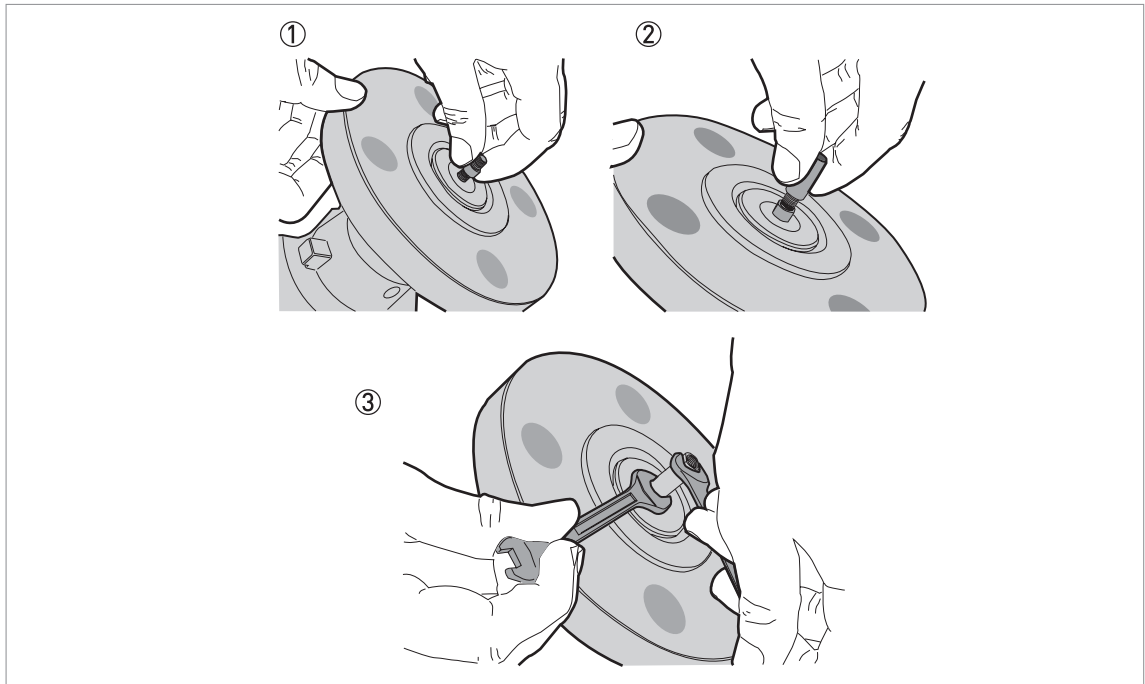

Figure 3-27: How to assemble the segmented single rod probe: part 1



CAUTION!

Make sure that the nuts are tight and the rod probe cannot loosen.



- Attach a lock nut to the threaded rod below the process connection. Turn the nut until it is $\frac{3}{4}$ along the length of the rod.
- Attach a union nut to the threaded rod below the process connection.
- Use two 8 mm open-end wrenches to tighten the union nut against the lock nut.

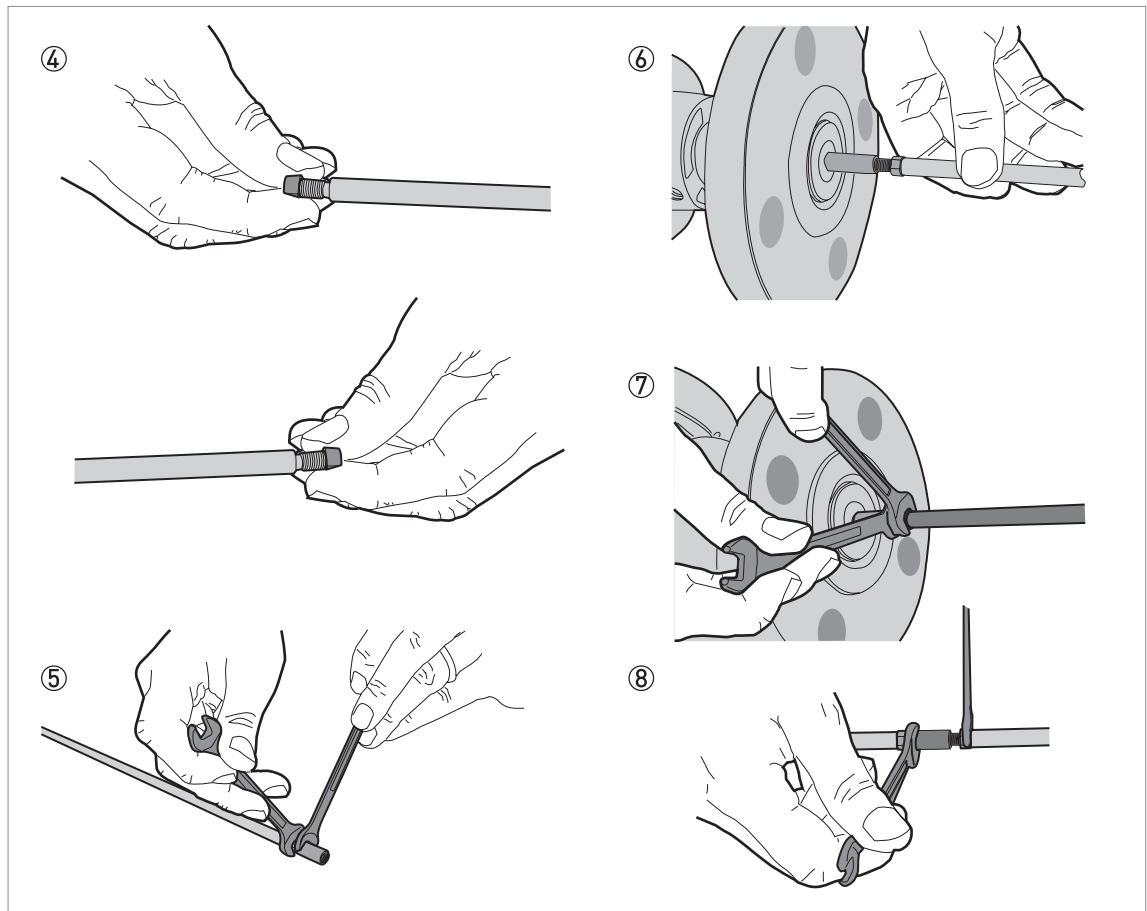

Figure 3-28: How to assemble the segmented single rod probe: part 2



WARNING!

Put a support below the probe to prevent deformation.



CAUTION!

Make sure that the nuts are tight and the rod probe cannot loosen.



- Attach a lock nut to each end of the rod probe segments.
- Attach a union nut to the bottom end of each rod probe segment, but not to the bottom segment. Use two 8 mm open-end wrenches to tighten the union nut against the lock nut.
- Attach the top segment of the rod probe to the union nut below the process connection. Use two 8 mm open-end wrenches to tighten the union nut against the lock nut on the rod probe.
- Attach the middle segment of the rod probe to the union nut on the top segment (if there are middle segments). Use two 8 mm open-end wrenches to tighten the union nut against the lock nut. Repeat this step for the other segments.
- Attach the bottom segment of the rod probe to the union nut on the top segment. Use two 8 mm open-end wrenches to tighten the union nut against the lock nut.

**CAUTION!**

Make sure that the length of the probe is correct. If the probe is too long, refer to How to decrease the length of probes on page 88.

3.8.3 How to assemble the segmented coaxial probe

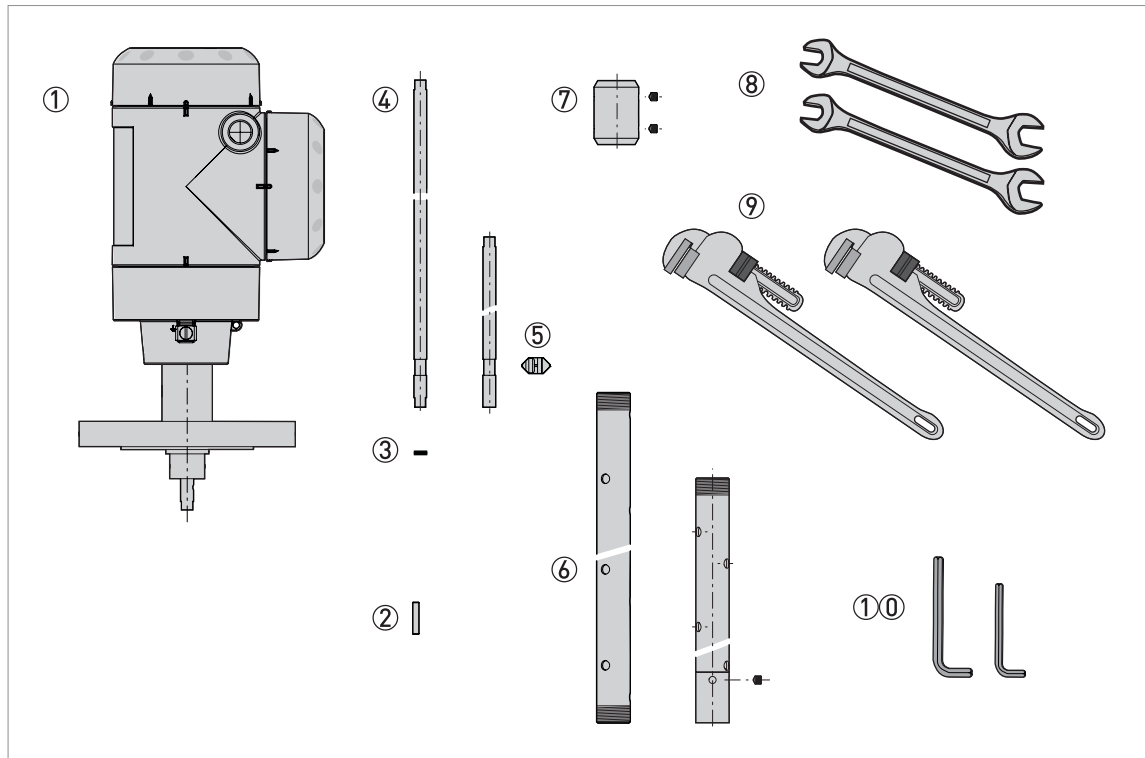

Figure 3-29: Equipment needed to assemble the coaxial probe

- ① Converter and process connection
- ② HC M4x20 screws (1 screw per probe segment)
- ③ Lockwashers (1 pair of washers per probe segment)
- ④ Top (quantity: 1), middle (quantity: 1 or more) and bottom (quantity: 1 - with 1 socket set screw M5x5) segments of the signal rod
- ⑤ PTFE spacer (1 spacer per probe segment)
- ⑥ Middle (quantity: 1 or more) and bottom (quantity: 1) segments of the coaxial tube
- ⑦ Union nut with 2 socket set screws M5x5 (1 union nut per segment of the coaxial tube)
- ⑧ Tools: two 7 mm open-end wrenches (not supplied)
- ⑨ Tools: two pipe (Stillson) wrenches (not supplied)
- ⑩ Tools: one 2.5 mm Allen wrench and one 2 mm Allen wrench (not supplied)

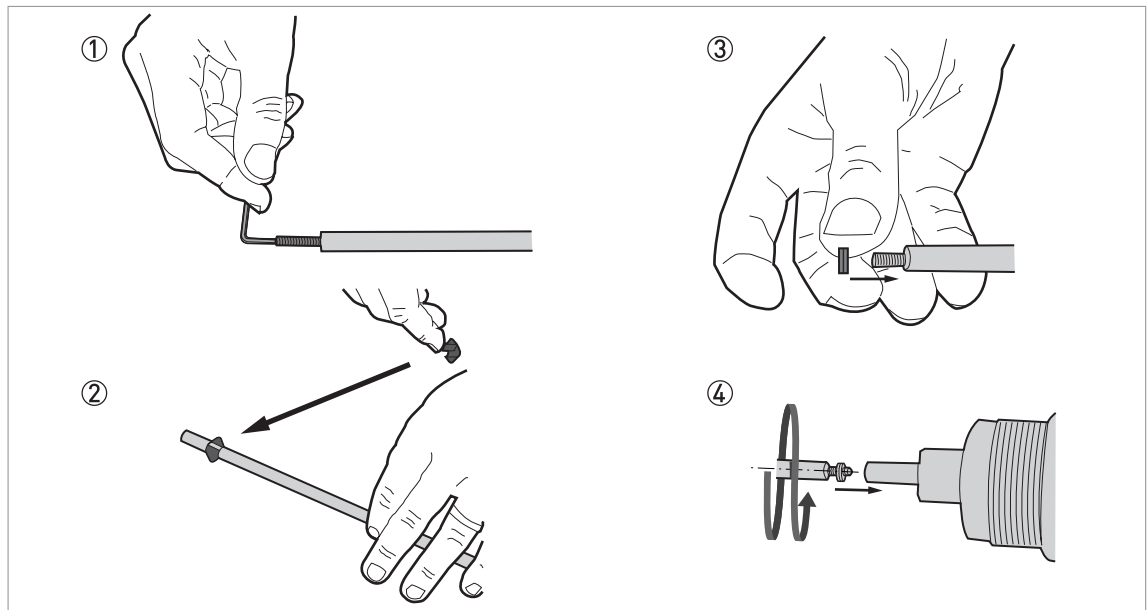

Figure 3-30: How to assemble the segmented coaxial probe: part 1



CAUTION!

Do not attach the screw to the end of the rod segment that has a groove for the attachment of a PTFE spacer.



- Use a 2 mm Allen wrench to attach and tighten a HC M4×20 screw at the top of each rod segment (intermediary and end rod segments)
- Attach a PTFE spacer to the end of each rod segment that has a groove.
- Attach a pair of lock washers at the top of each rod segment (intermediary and end rod segments)
- Assemble one of the middle rod segments (with a pair of lock washers on the attached screw) and the signal rod below. Use two 7 mm open-ended wrenches to tighten the assembled parts to a torque of 2...3 Nm.

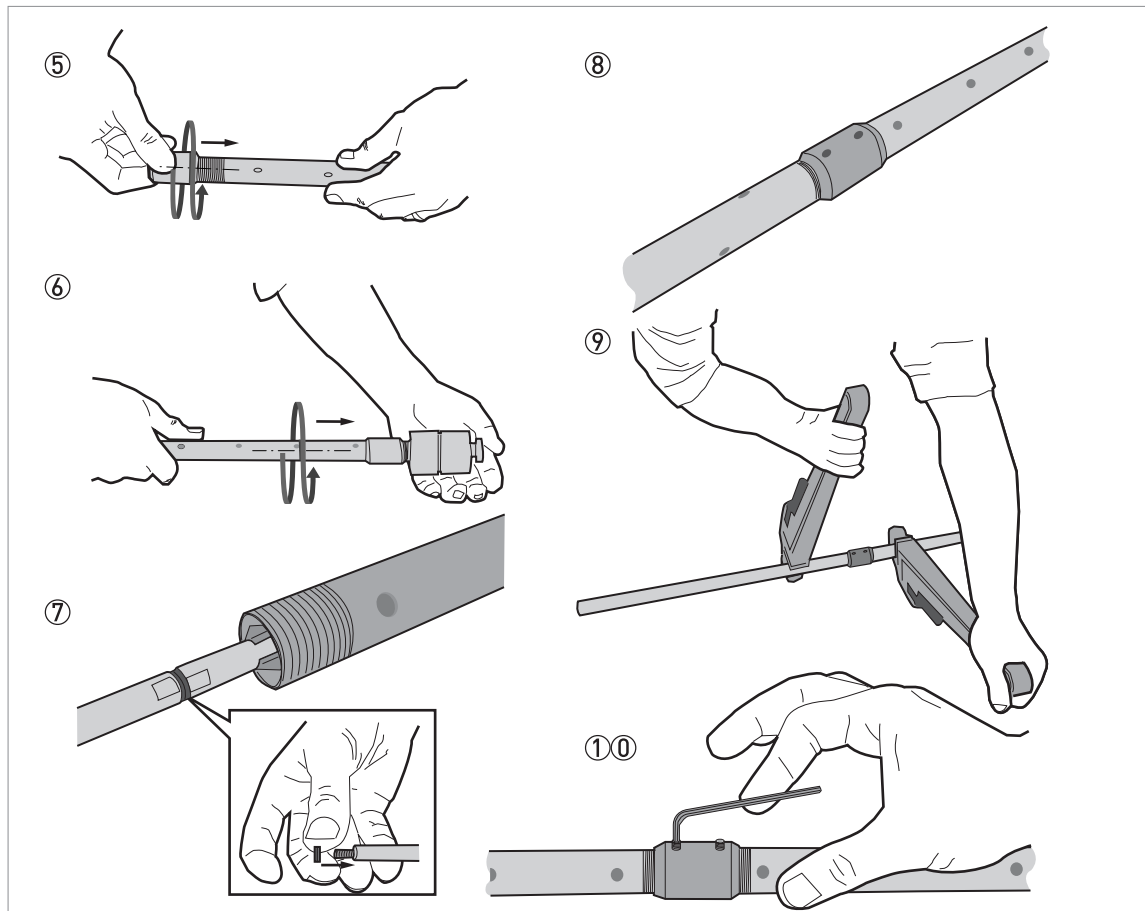

Figure 3-31: How to assemble the segmented coaxial probe: part 2



WARNING!

Be careful when you use the pipe wrenches. Make sure that the measuring tubes have no deformation.



CAUTION!

- *Make sure that the screws are tight and the measuring tube cannot loosen.*
- *Make sure that the fitting for the lock screw is not aligned with a hole in the coaxial tube.*



- Attach a union nut to each coaxial tube (middle and end tubes)
- Attach a middle tube segment to the coaxial probe stem. Do not use tools to tighten the assembled parts.
- Assemble the next middle rod segment (with a pair of lock washers on the attached screw) and the top rod segment. Use two 7 mm open-ended wrenches to tighten the assembled parts to a torque of 2...3 Nm.
- Assemble the next coaxial tube segment and the top coaxial tube segment. Do not use tools to tighten the assembled parts. Do steps (9) thru (10) again until the end rod segment and end coaxial tube are attached.
- Use the 2 pipe wrenches to tighten the coaxial tubes in the lock nuts.
- Use a 2.5 mm Allen wrench to attach and tighten the two HC M5×5 screws (lock screws) to the union nut.

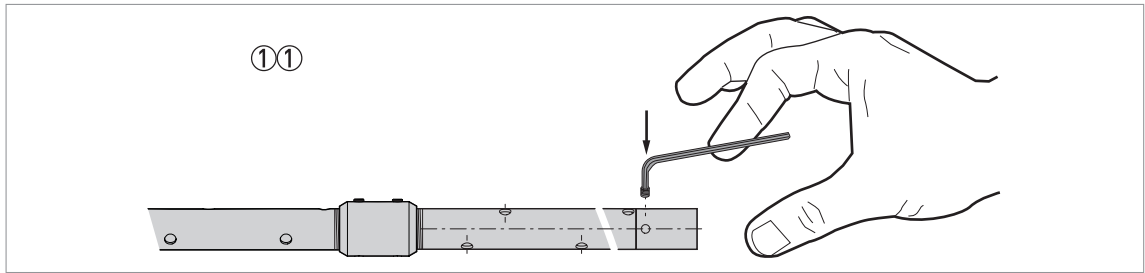

Figure 3-32: How to assemble the segmented coaxial probe: part 3



CAUTION!

If the lock screw is not tight, the device will not measure correctly.



- Use a 2.5 mm Allen wrench to attach and tighten a HC M5×5 screw (lock screw) to the bottom segment of tube.

3.8.4 How to install a device with a flange connection

Equipment needed:

- Device
- Gasket (not supplied)
- Wrench (not supplied)

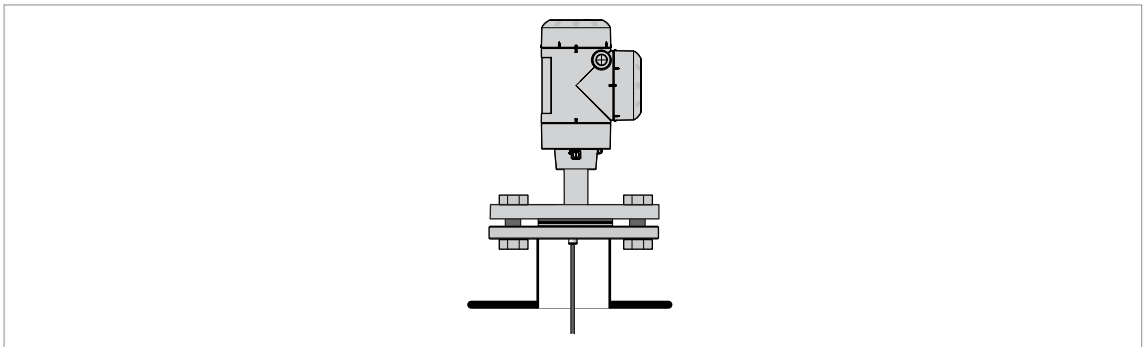

Figure 3-33: Flange connection



- Make sure the flange on the nozzle is level.
- Make sure that you use the applicable gasket for the flange and the process.
- Align the gasket correctly on the flange facing of the nozzle.
- Lower the probe carefully into the tank.
- ➡ For more data on cable probes, refer to *How to install a cable probe in the tank* on page 41.
- Tighten the flange bolts.
- ➡ Refer to local rules and regulations for the correct torque to apply to the bolts.

3.8.5 How to install a device with a threaded connection

Equipment needed:

- Device
- Gasket (not supplied)
- 50 mm / 2" wrench (not supplied)

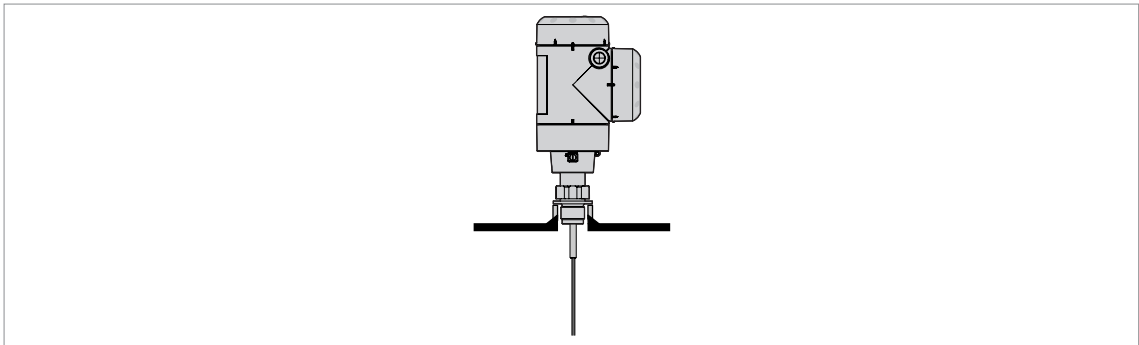

Figure 3-34: Threaded connection



- Make sure the tank connection is level.
- Make sure that you use the applicable gasket for the connection and the process.
- Align the gasket correctly.
- If the device is installed on a tank made of plastic or other non-conductive material, refer to *Recommendations for pits and tanks made of non-conductive materials* on page 42.
- Lower the probe carefully into the tank.
- ➡ For more data on cable probes, refer to *How to install a cable probe in the tank* on page 41.
- Use 50 mm / 2" wrench to attach the process connection to the tank.
- Tighten the nut.
- ➡ Refer to local rules and regulations for the correct torque to apply to the connection.



INFORMATION!

*If there is not sufficient clearance to install the device, remove the housing. Install the probe and then put the housing back on the process connection. For more data, refer to *How to turn or remove the signal converter* on page 43.*

3.8.6 How to install a cable probe in the tank

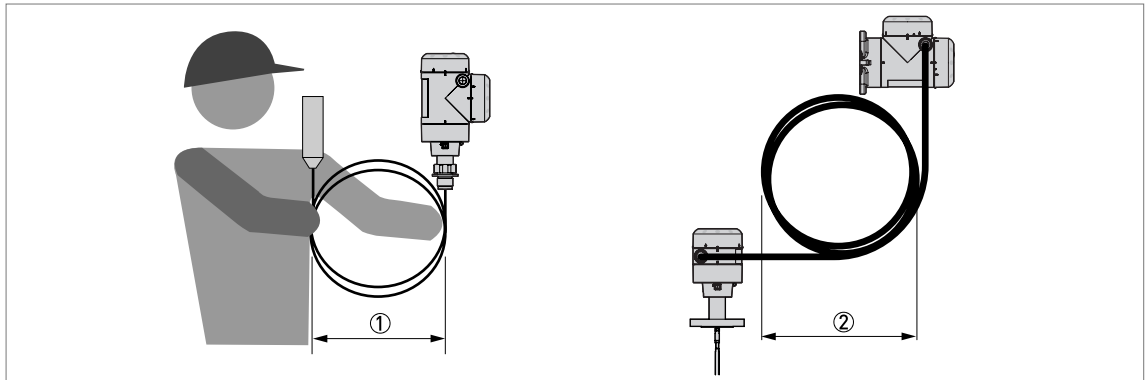

Figure 3-35: Wind cable probes and electrical cables carefully



WARNING!

If you bend the probe too much, you will damage the device and it will not measure accurately.

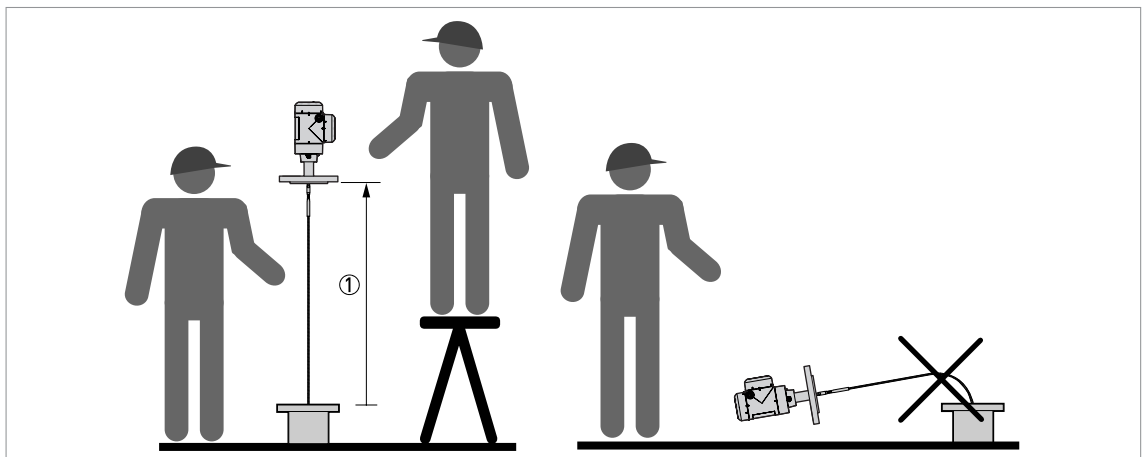

Figure 3-36: Installation of devices with cable probes

① >1 m / 3½ ft



- Use two persons to lift the housing and the probe above the process connection.
- Hold the device 1 m / 3½ ft above the tank.
- Unwind the probe carefully into the tank.

3.8.7 Recommendations for pits and tanks made of non-conductive materials



If you have a device with a single rod or a single cable probe and a thread connection, obey these instructions:

- Put a metal sheet between the device and the process connection.
- It must have a diameter greater than 200 mm / 8".
- Make sure that the metal sheet is in contact with the thread stop on the device.

We recommend that you use $DN \geq 200$ / $\geq 8''$ for flange connections.

If you have a device with a double rod, double cable or coaxial probe, you can ignore these instructions.

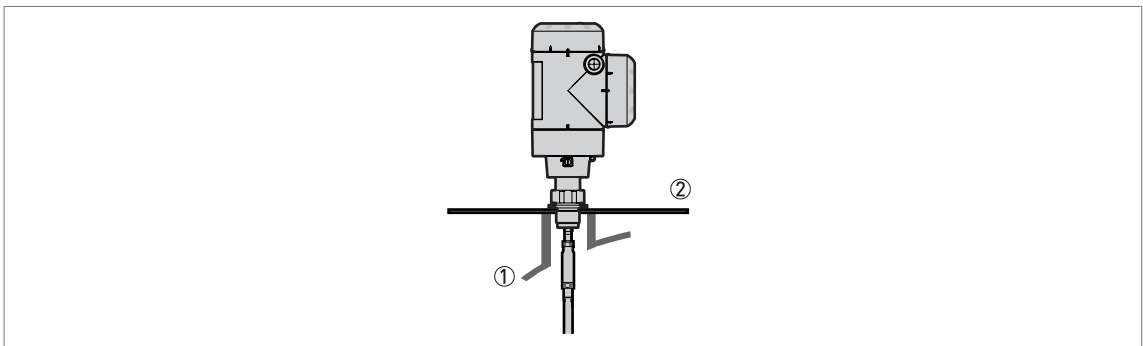

Figure 3-37: Installation in a non-metallic tank or pit with a thread connection

- ① Non-metallic (plastic...) tank or pit
- ② Metal sheet, $\varnothing \geq 200$ mm / 8"



CAUTION!

When the device is installed, make sure that the tank roof has no deformation.

3.8.8 How to turn or remove the signal converter

The converter turns 360°. The converter can be removed from the process connection assembly under process conditions.

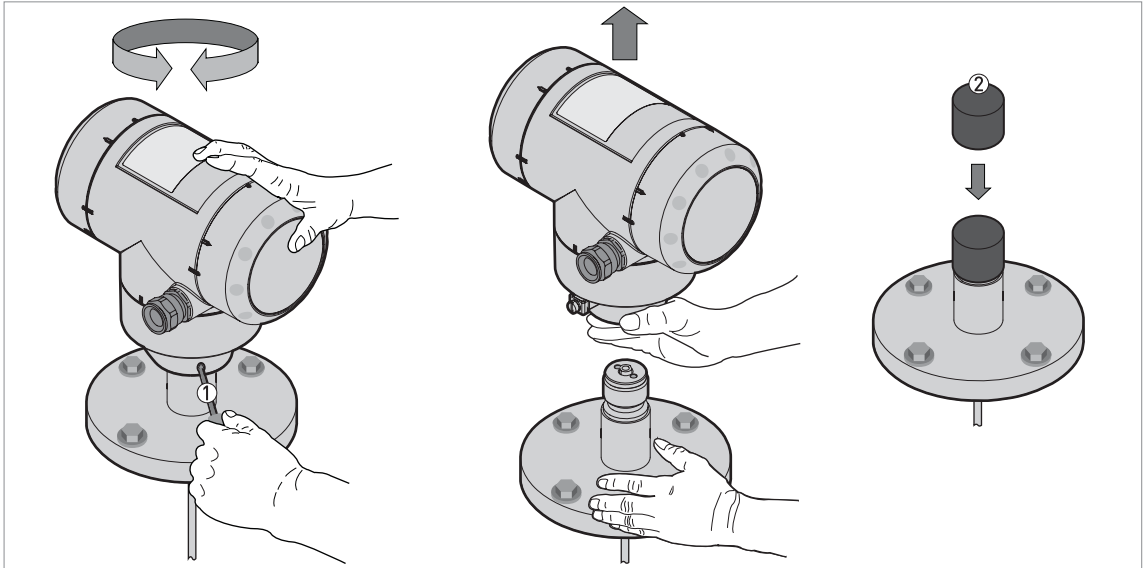

Figure 3-38: How to turn or remove the signal converter

- ① Tool: 5 mm Allen wrench (not supplied) for the lock screw on the signal converter
- ② Cover for the coaxial hole on top of the process connection assembly



CAUTION!

Do not loosen the 4 socket head screws on the process connection assembly.

If you remove the housing, put a cover on the the coaxial hole on top of the process connection assembly.

When the housing is attached to the process connection assembly, tighten the lock screw.

3.8.9 How to attach the weather protection to the device

The device and the weather protection option are supplied disassembled in the same box. You must attach the weather protection when you install the device.

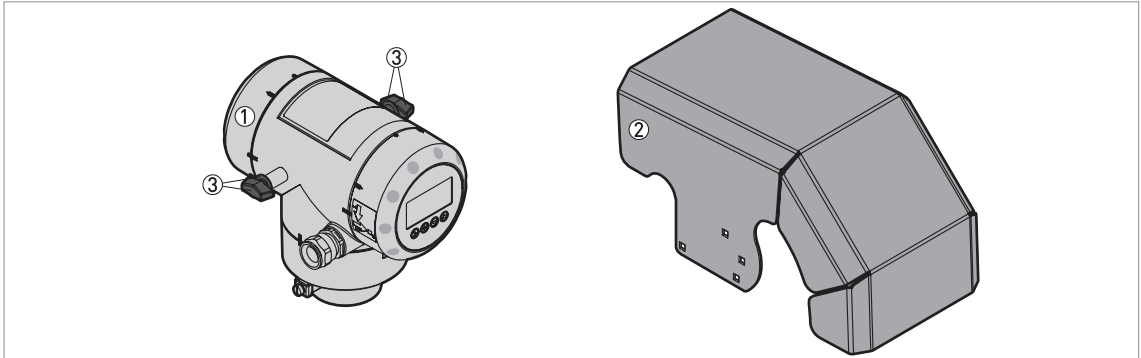

Figure 3-39: Equipment needed

- ① Device
- ② Weather protection (option).
- ③ 2 butterfly screws and spring washers. The manufacturer attaches these parts to the device before delivery.

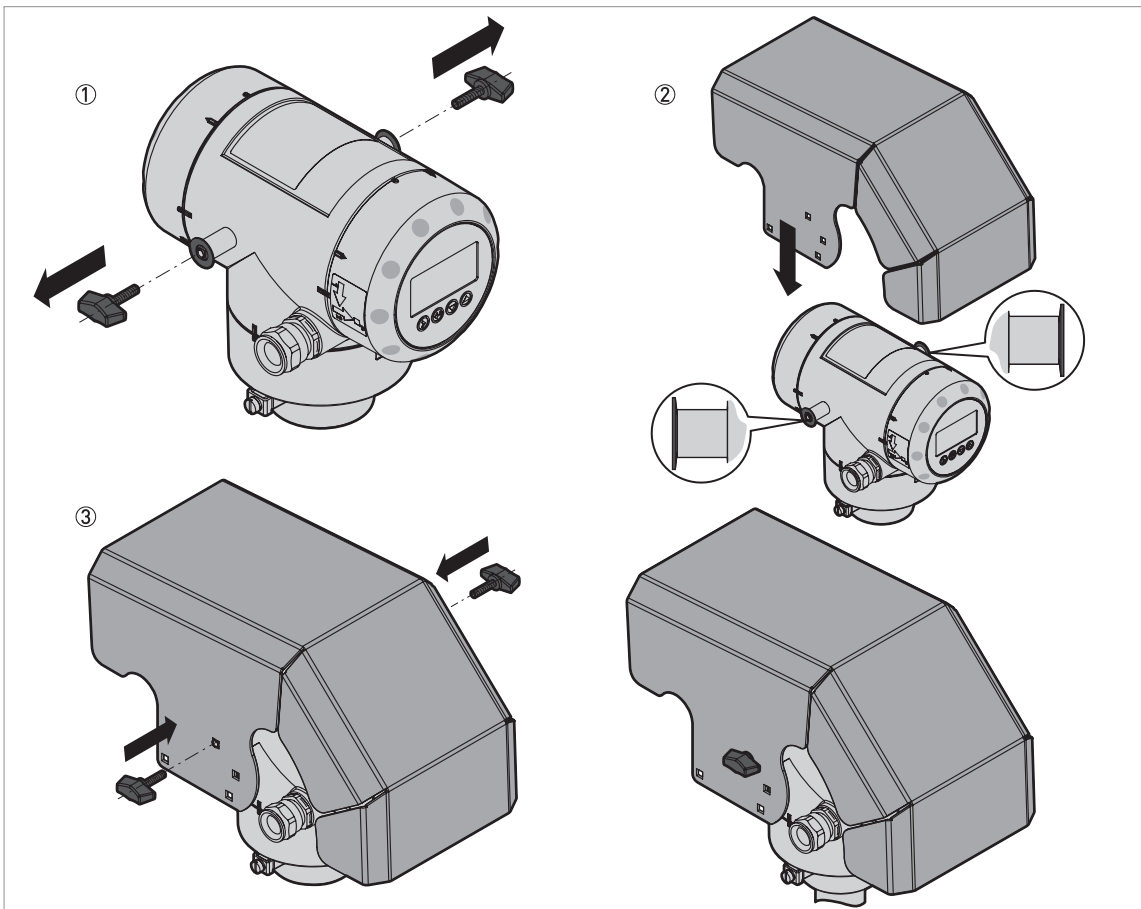

Figure 3-40: Installation of the weather protection (general procedure)



- ① Remove the 2 butterfly screws from the housing. Make sure that spring washer is attached correctly to the housing (on the weather protection fixture).
- ② Lower the weather protection onto the device.
- ③ Attach the 2 butterfly screws. Make sure that you use the correct holes to attach the weather protection. The holes must agree with the housing option used (compact vertical (non-Ex or Ex i-approved etc.)). For more data, refer to the illustration that follows:

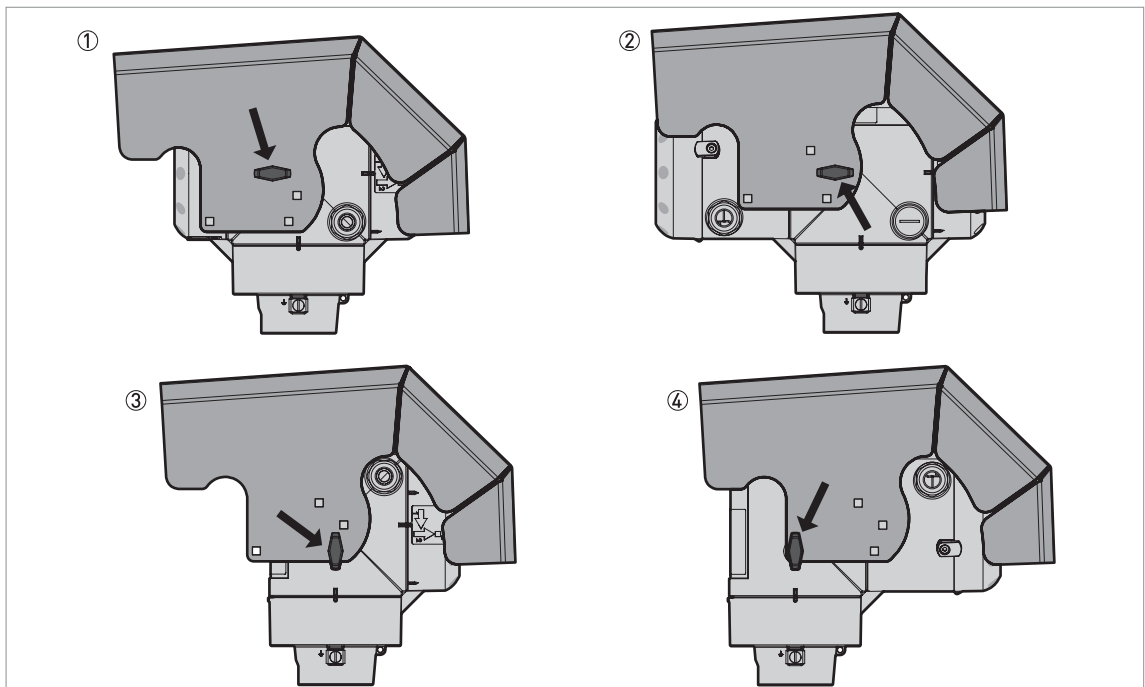

Figure 3-41: Holes for installation of the weather protection (housing versions)

- ① Compact horizontal housing (non-Ex and Ex i-approved devices)
- ② Compact horizontal housing (Ex d-approved devices)
- ③ Compact vertical housing (non-Ex and Ex i-approved devices)
- ④ Compact vertical housing (Ex d-approved devices)

The overall dimensions of the weather protection are on page 124.

3.8.10 How to open the weather protection

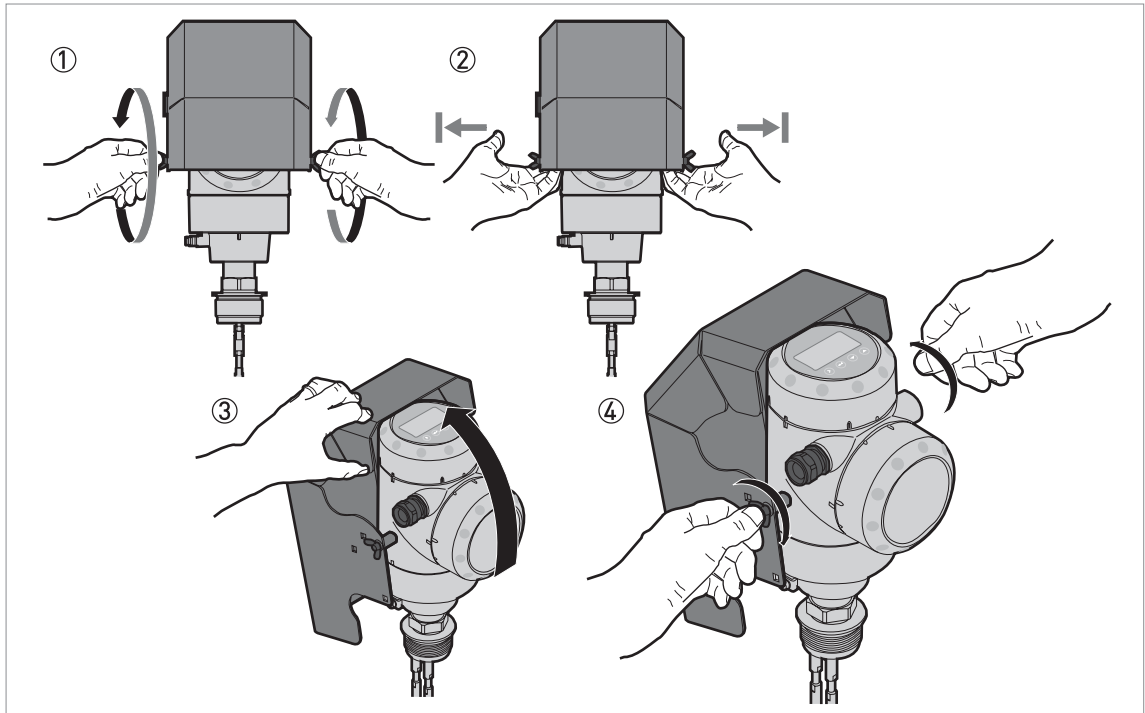

Figure 3-42: How to open the weather protection



- ① Loosen the bolt on each side of the weather protection.
- ② Pull the sides of the weather protection out of the notch for the closed position.
- ③ Pull the weather protection up and back.
- ➡ This will open the weather protection.
- ④ Tighten the bolts to lock the weather protection in its open position.

4.1 Safety instructions



DANGER!

All work on the electrical connections may only be carried out with the power disconnected. Take note of the voltage data on the nameplate!



DANGER!

Observe the national regulations for electrical installations!



DANGER!

For devices used in hazardous areas, additional safety notes apply; please refer to the Ex documentation.



WARNING!

Observe without fail the local occupational health and safety regulations. Any work done on the electrical components of the measuring device may only be carried out by properly trained specialists.



INFORMATION!

Look at the device nameplate to ensure that the device is delivered according to your order. Check for the correct supply voltage printed on the nameplate.

4.2 Electrical installation: 2-wire, loop-powered

4.2.1 Compact version

Terminals for electrical installation

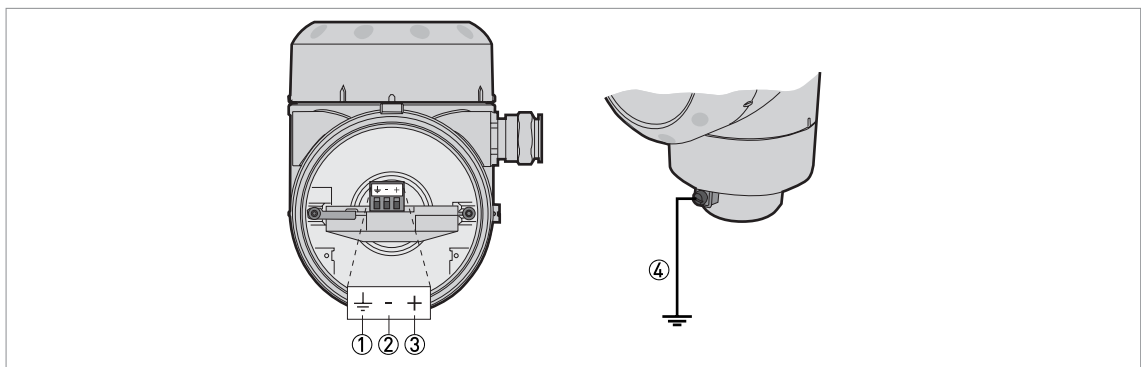

Figure 4-1: Terminals for electrical installation

- ① Grounding terminal in the housing (if the electrical cable is shielded)
- ② Current output -
- ③ Current output +
- ④ Location of the external grounding terminal (at the bottom of the converter)



INFORMATION!

Electrical power to the output terminal energizes the device. The output terminal is also used for HART® communication.

**CAUTION!**

- Use the applicable electrical cables with the cable glands.
- Make sure that the power supply does not have a current more than 5 A or that there is 5 A-rated fuse in the electrical circuit that energizes the device.
- Make sure that the polarity of the power supply is correct. If the polarity is incorrect, you will not cause damage to the device but the device will not operate.

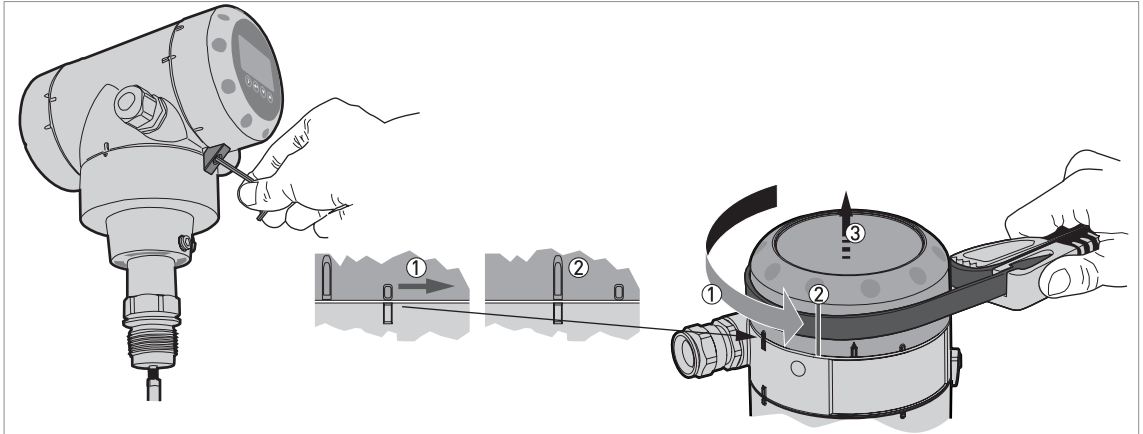

Figure 4-2: How to open the terminal compartment cover



- Loosen the lock screw with a 2.5 mm Allen wrench.
- Turn the cover counterclockwise with a strap wrench.
- Remove the cover.

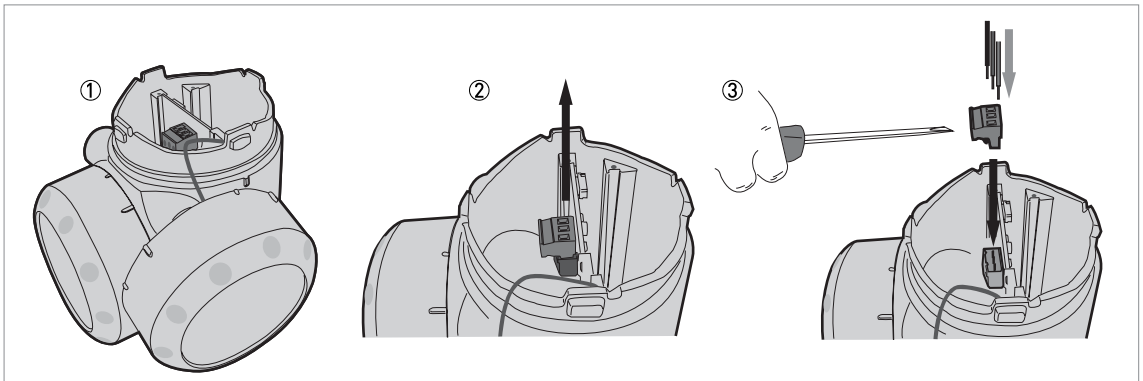

Figure 4-3: Procedure for electrical installation

Equipment needed:

- Small slotted tip screwdriver (not supplied)

**Procedure:**

- ① Do not disconnect the safety cord from the terminal compartment cover. Put the terminal compartment cover adjacent to the housing.
- ② Remove the connector from the circuit board.
- ③ Connect the electrical wires to the connector. Attach the connector to the circuit board. Tighten the cable entry glands.

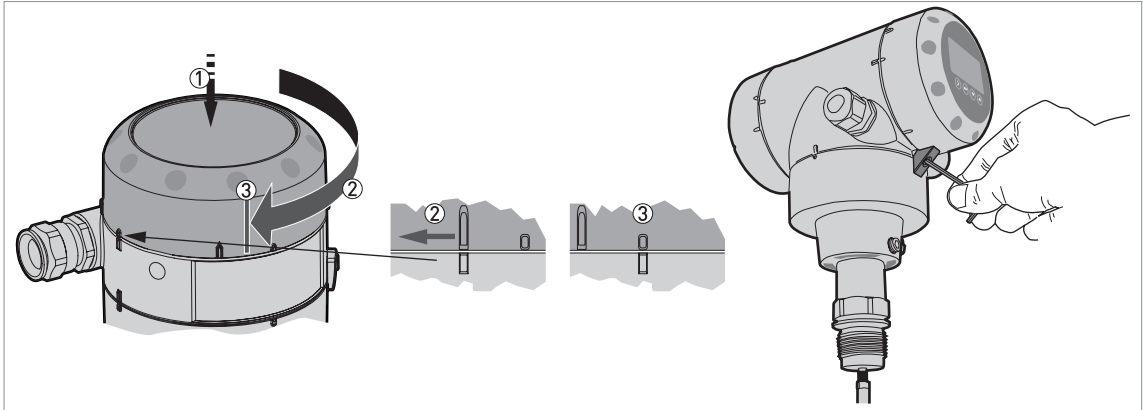

Figure 4-4: How to close the terminal compartment cover



- Put the cover on the housing and push it down.
- Turn the cover clockwise until it is fully engaged.
- Tighten the lock screw.

4.2.2 Remote version

Terminals for electrical installation

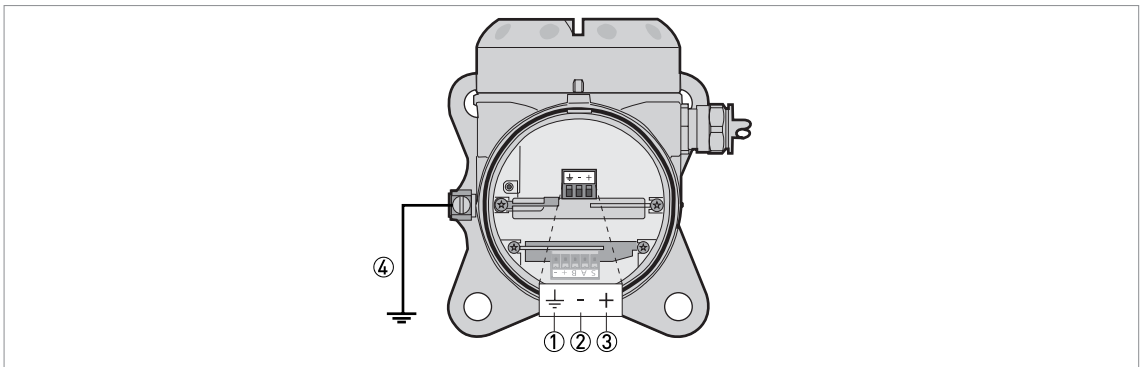

Figure 4-5: Terminals for electrical installation

- ① Grounding terminal in the housing (if the electrical cable is shielded)
- ② Current output -
- ③ Current output +
- ④ Location of the external grounding terminal (on the wall support)

**INFORMATION!**

Electrical power to the output terminal energizes the device. The output terminal is also used for HART[®] communication.

**CAUTION!**

- Use the applicable electrical cables with the cable glands.
- Make sure that the power supply does not have a current more than 5 A or that there is 5 A-rated fuse in the electrical circuit that energizes the device.
- Make sure that the polarity of the power supply is correct. If the polarity is incorrect, you will not cause damage to the device but the device will not operate.

For more electrical installation data, refer to *Compact version* on page 47.

4.3 Remote device data

4.3.1 Requirements for signal cables supplied by the customer

**DANGER!**

An Ex-approved signal cable is supplied by the manufacturer with devices for hazardous locations. Use of this signal cable is mandatory.

Non-Ex devices only: The signal cable is an option for non-Ex devices. If the signal cable is not supplied by the device manufacturer, the cable must have properties that follow:

Basic properties

- Twisted cable 2 by 2, shielded or screened. For example, multicore cable — reference MCD 5123 — from Cabletec ICS/JP Electronics.

Maximum length of the signal cable

- 100 m / 328 ft

Temperature

- Use electrical cable with the applicable temperature rating for the operating conditions.
- Ambient temperature range: -40...+80°C / -40...+175°F
- We recommend that the cable agrees with UL 94V-0.

Dimensions of the insulated conductors

- Min.-max. cross-sectional area of the conductors: 4×0.326...4×2.5 mm² (22....14 AWG), shielded cable
- Use the applicable cable for the cable glands (∅6....10 mm / 0.24...0.39").
- Use the applicable cable glands for the cable entry openings in the housing.

Electrical characteristics

- Test voltage: Insulated conductor / shield (screen) ≥ 500 VAC
- Line resistance: < 55 Ω/km
- The cable must agree with EN 60811 (Low Voltage Directive) or equivalent national regulations.

4.3.2 How to prepare a signal cable supplied by the customer

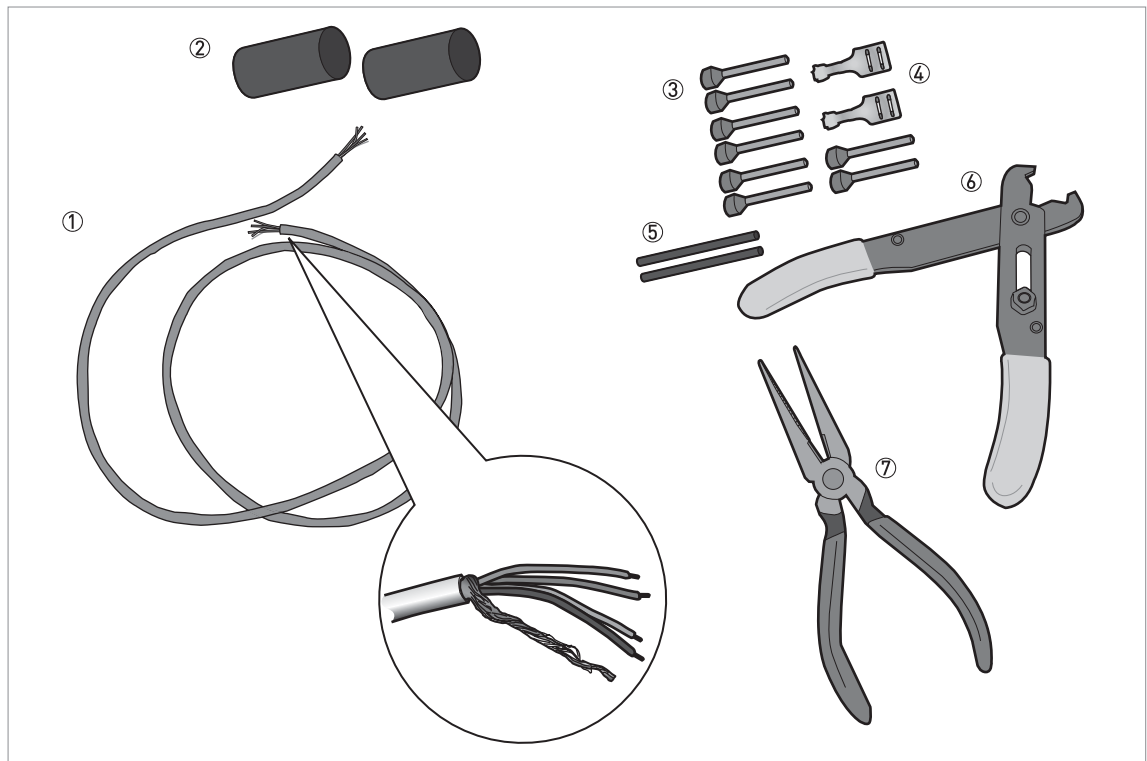

Figure 4-6: Equipment needed to prepare the signal cable

- ① Signal cable (supplied on request)
- ② 2 heat-shrinkable sleeves for the PVC jacket (not supplied)
- ③ 8 ferrules for the end of the conductors (not supplied)
- ④ 2 Faston connectors for the shield wires
- ⑤ Shield wire insulation, 2 sleeves
- ⑥ Wire stripper (not supplied)
- ⑦ Crimping pliers (not supplied)



INFORMATION!

- The Faston connector for the stranded drain wire must agree with DIN 46 228: E 1.5-8
- The wire end ferrules for the twisted pair of conductors must agree with DIN 46 228: E 0.5-8

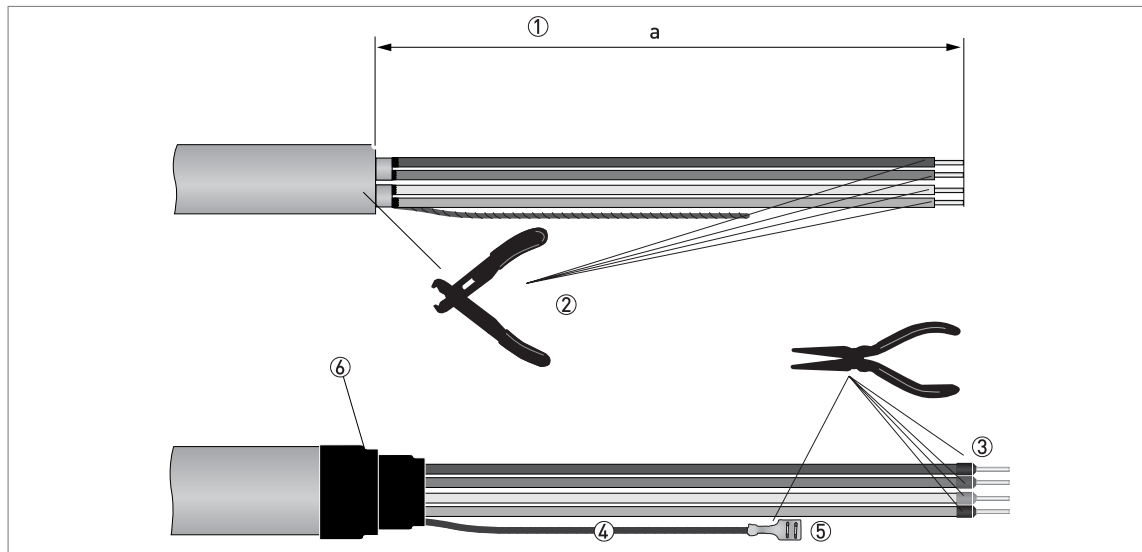

Figure 4-7: How to prepare the signal cable
a = 50 mm / 2"



- ① Remove the PVC jacket from the wire to dimension "a".
- ② Remove the insulation from the wire. Obey national regulations for electrical wiring.
- ③ Crimp the wire end ferrules on the conductors.
- ④ Install shield wire insulation on the 2 ends of the shield wire.
- ⑤ Crimp the Faston connectors on the 2 ends of the shield wire.
- ⑥ Install a heat-shrinkable sleeve on the PVC jacket.

4.3.3 How to connect the signal cable to the device



DANGER!

Cables may only be connected when the power is switched off.



DANGER!

The device must be grounded in accordance with regulations in order to protect personnel against electric shocks.



DANGER!

For devices used in hazardous areas, additional safety notes apply; please refer to the Ex documentation.



WARNING!

Observe without fail the local occupational health and safety regulations. Any work done on the electrical components of the measuring device may only be carried out by properly trained specialists.

Equipment needed

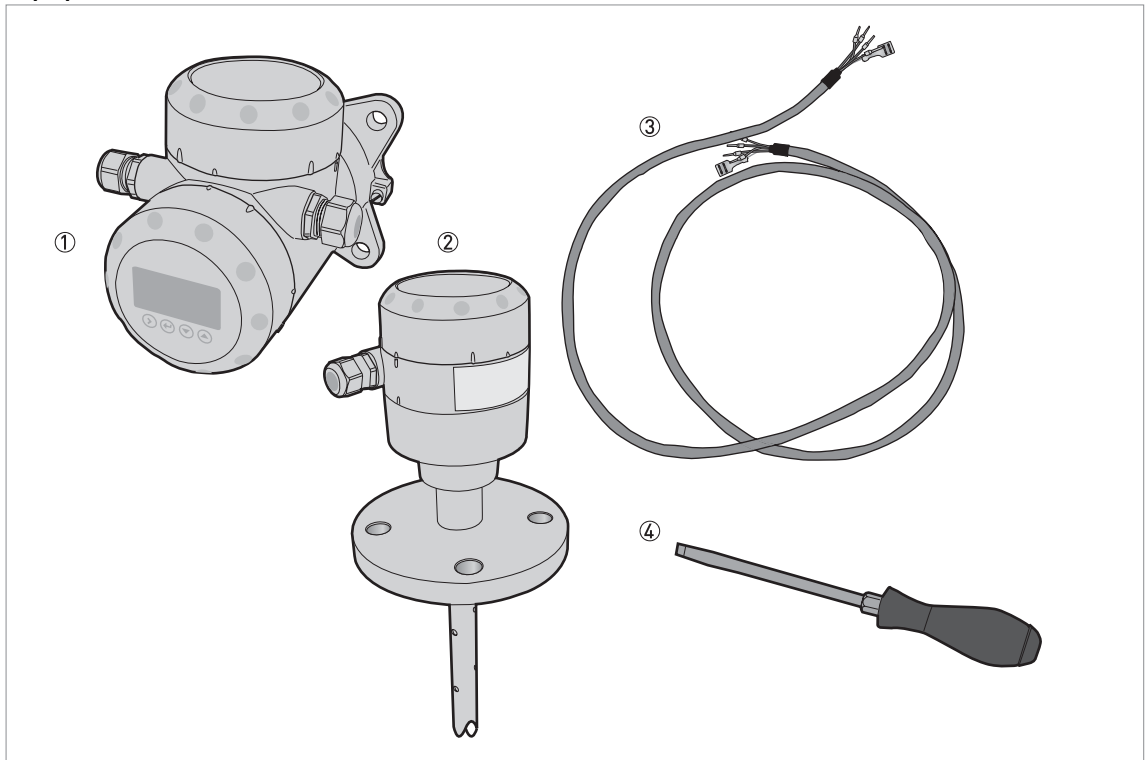

Figure 4-8: Equipment needed to prepare the signal cable

- ① Remote converter
- ② Probe housing
- ③ Signal cable (supplied on request for non-Ex devices) - for more data, refer to *How to prepare a signal cable supplied by the customer* on page 51
- ④ Small slotted-tip screwdriver (not supplied)

Connections between the remote converter and the probe housing

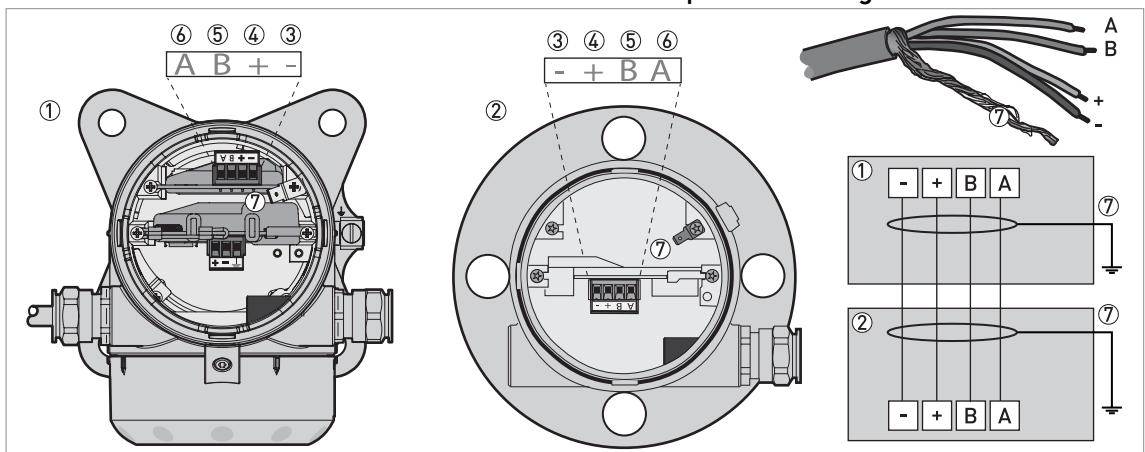

Figure 4-9: Connections between the remote converter and the probe housing

- ① Remote converter
- ② Probe housing
- ③ Power supply: voltage in -
- ④ Power supply: voltage in +
- ⑤ Signal cable B
- ⑥ Signal cable A
- ⑦ Shielding wire (attached to Faston connectors in the housings of the remote converter and the probe housing)

How to connect the signal cable to the remote converter

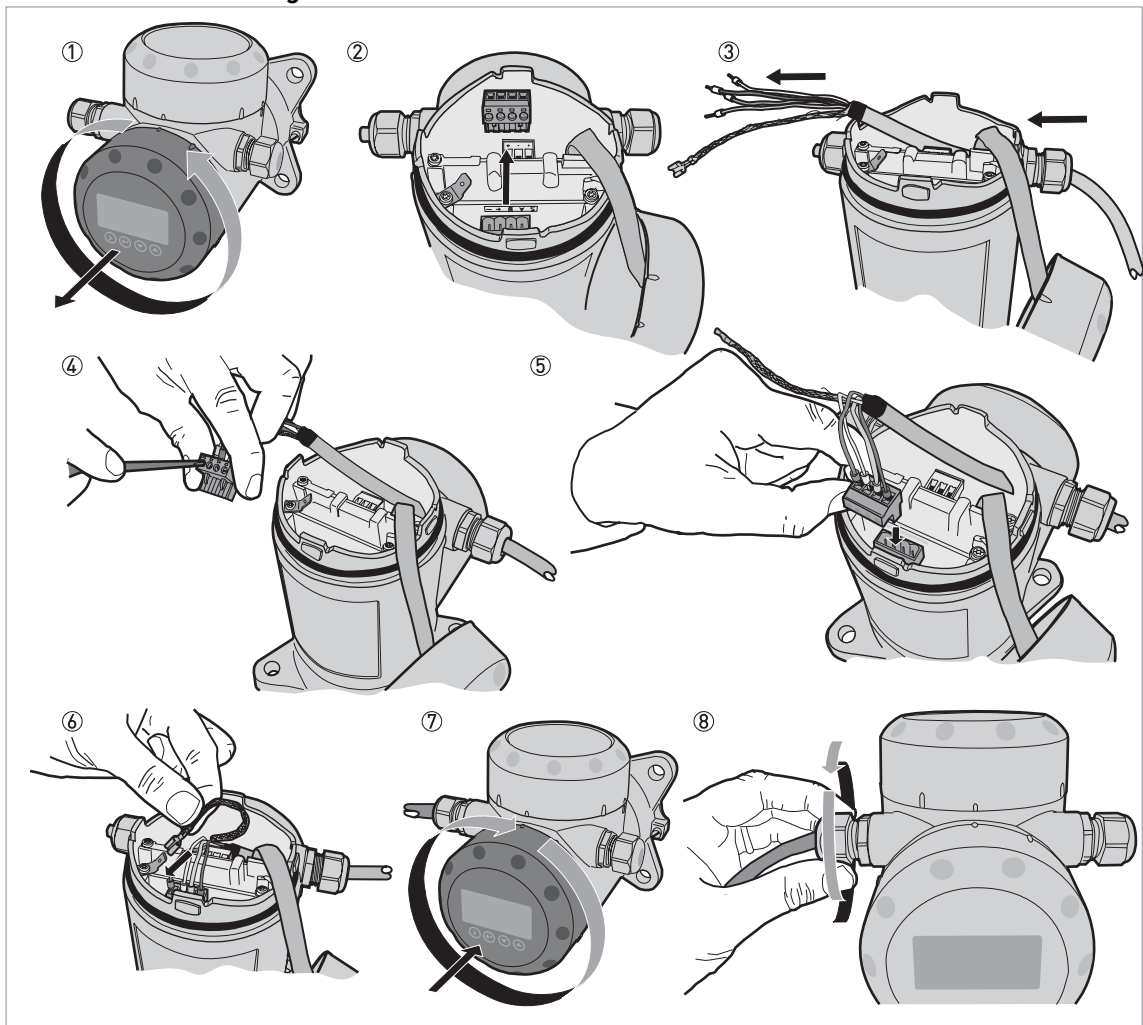

Figure 4-10: How to connect the signal cable to the remote converter

**CAUTION!**

Bending radius of the signal cable: ≥ 50 mm / 2"



- ① Remove the terminal compartment cover.
- ② Remove the 4-pin connector.
- ③ Put the signal cable into the opening of the cable gland.
- ④ Put the electrical wires in the connector terminals. Tighten the terminal screws with a small slotted-tip screwdriver. Make sure that the electrical wires agree with the terminals. For more data, refer to the electrical schema in this section.
- ⑤ Put the connector into the 4-pin socket.
- ⑥ Attach the Faston connector (drain wire).
- ⑦ Attach the terminal compartment cover.
- ⑧ Tighten the cable gland. Make sure that the remote converter is correctly sealed.

How to connect the signal cable to the probe housing

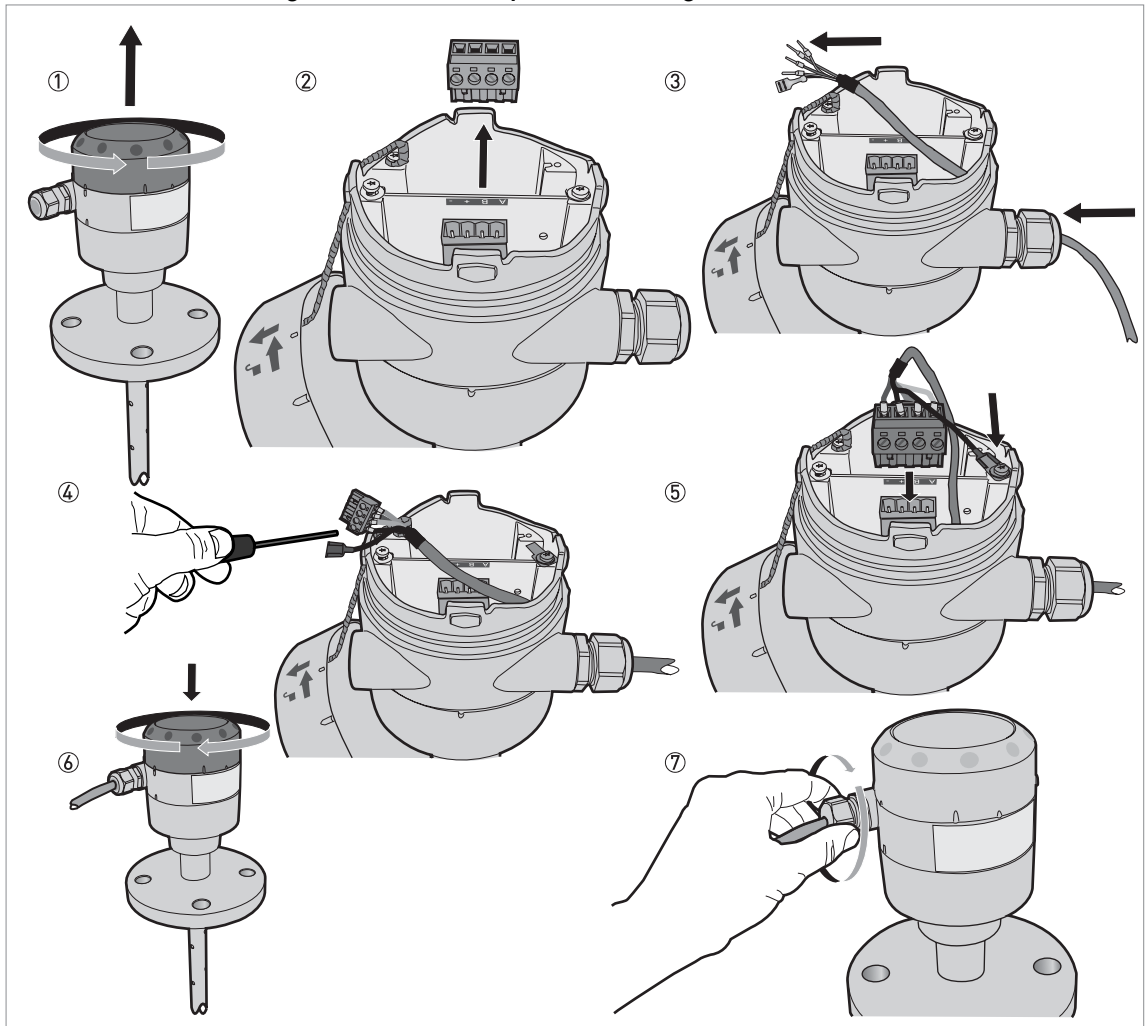

Figure 4-11: How to connect the signal cable to the probe housing

**CAUTION!**

Bending radius of the signal cable: ≥ 50 mm / 2"



- ① Remove the terminal compartment cover.
- ② Remove the 4-pin connector.
- ③ Put the signal cable into the opening of the cable gland.
- ④ Put the electrical wires in the connector terminals. Tighten the terminal screws with a small slotted-tip screwdriver. Make sure that the electrical wires agree with the terminals. For more data, refer to the electrical schema in this section.
- ⑤ Put the connector into the 4-pin socket. Attach the Faston connector (drain wire).
- ⑥ Attach the terminal compartment cover.
- ⑦ Tighten the cable gland. Make sure that the probe housing is correctly sealed.

4.4 Electrical connection for current output

4.4.1 Non-Ex devices

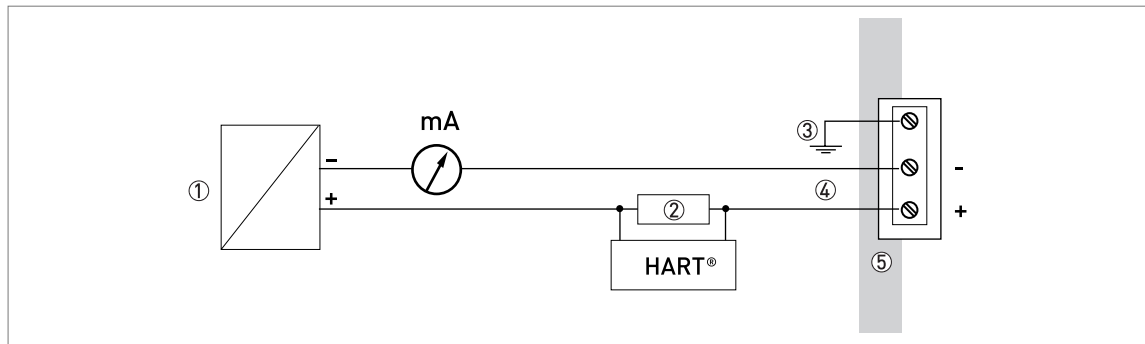

Figure 4-12: Electrical connections for non-Ex devices

- ① Power supply
- ② Resistor for HART® communication
- ③ Optional connection to the grounding terminal
- ④ Output: 12...30 VDC for an output of 22 mA at the terminal
- ⑤ Device

4.4.2 Devices for hazardous locations



DANGER!

For electrical data for device operation in hazardous locations, refer to the related certificates of compliance and supplementary instructions (ATEX, IECEx, cFMus, ...). You can find this documentation on the DVD-ROM delivered with the device or it can be downloaded free of charge from the website (Download Center).

4.5 Protection category



INFORMATION!

The device fulfills all requirements per protection category IP 66/67. It also fulfils all requirements per NEMA type 4X (housing) and type 6P (probe).



DANGER!

Make sure that the cable gland is watertight.

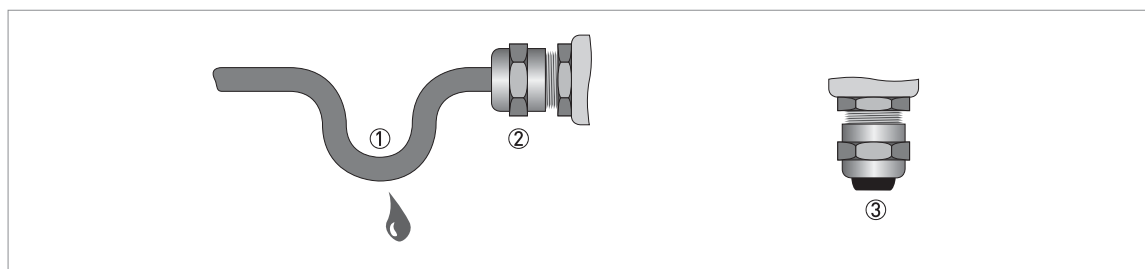

Figure 4-13: How to make the installation agree with protection category IP 67



- Make sure that the gaskets are not damaged.
- Make sure that the electrical cables are not damaged.
- Make sure that the electrical cables agree with the national electrical code.
- The cables are in a loop in front of the device ① so water does not go into the housing.
- Tighten the cable feedthroughs ②.
- Close unused cable feedthroughs with dummy plugs ③.

The diameter of the outer sheath of the electrical cable and must be 6...10 mm or 0.2...0.39".

4.6 Networks

4.6.1 General information

The device uses the HART[®] communication protocol. This protocol agrees with the HART[®] Communication Foundation standard. The device can be connected point-to-point. It can also operate in a multi-drop network of up to 15 devices.

The device output is factory-set to communicate point-to-point. To change the communication mode from **point-to-point** to **multi-drop**, refer to *HART[®] network configuration* on page 82.

4.6.2 Point-to-point networks

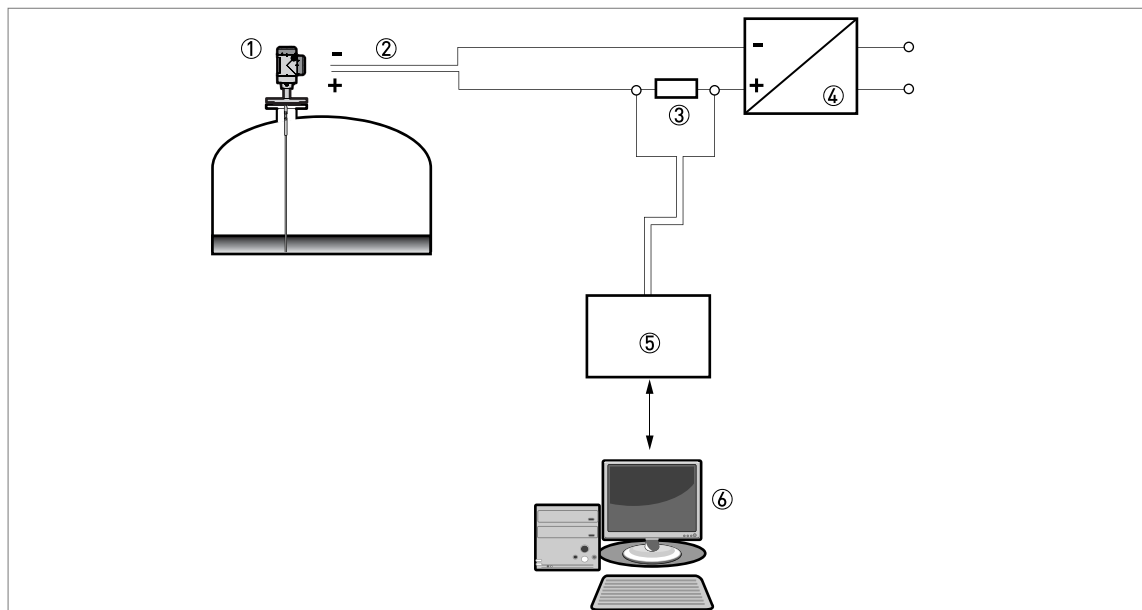

Figure 4-14: Point-to-point connection (non-Ex)

- ① Address of the device (0 for a point-to-point connection)
- ② 4...20 mA + HART[®]
- ③ Resistor for HART[®] communication
- ④ Power supply
- ⑤ HART[®] modem
- ⑥ HART[®] communication device

4.6.3 Multi-drop networks

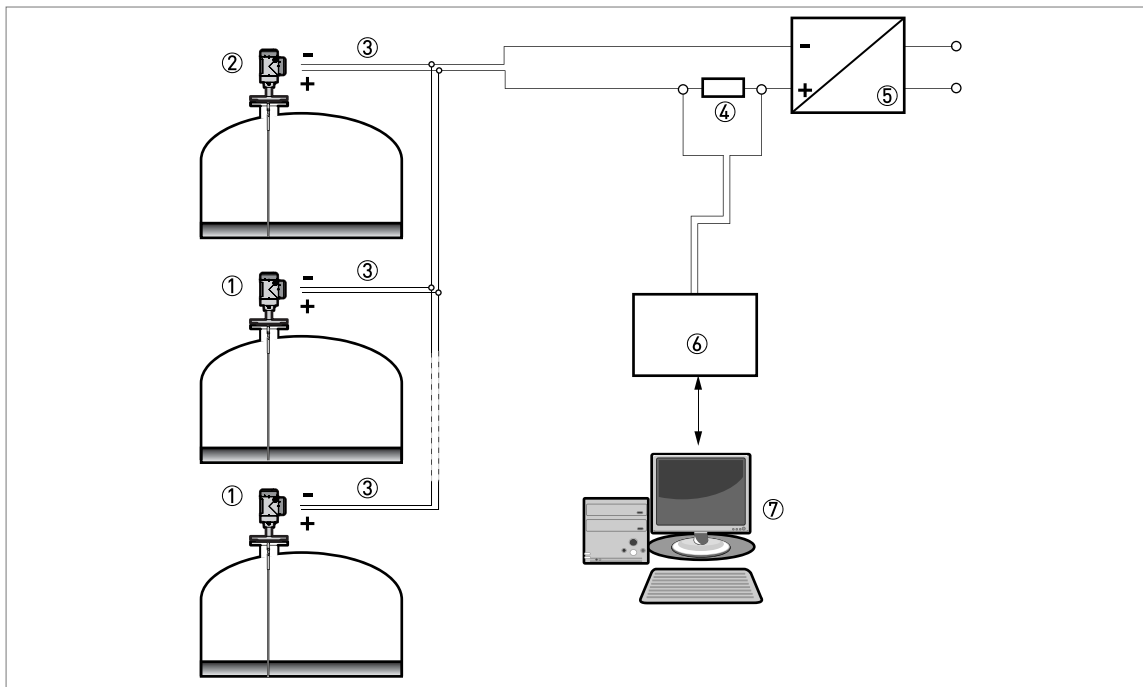

Figure 4-15: Multi-drop network (non-Ex)

- ① Address of the device (n+1 for multidrop networks)
- ② Address of the device (1 for multidrop networks)
- ③ 4 mA + HART®
- ④ Resistor for HART® communication
- ⑤ Power supply
- ⑥ HART® modem
- ⑦ HART® communication device

4.6.4 Fieldbus networks



INFORMATION!

The FOUNDATION™ fieldbus and PROFIBUS PA options are pending. Fieldbus options are available for the compact version of the device.

For more data, refer to the supplementary instructions for FOUNDATION™ fieldbus and PROFIBUS PA.

FOUNDATION™ fieldbus network (non-Ex)

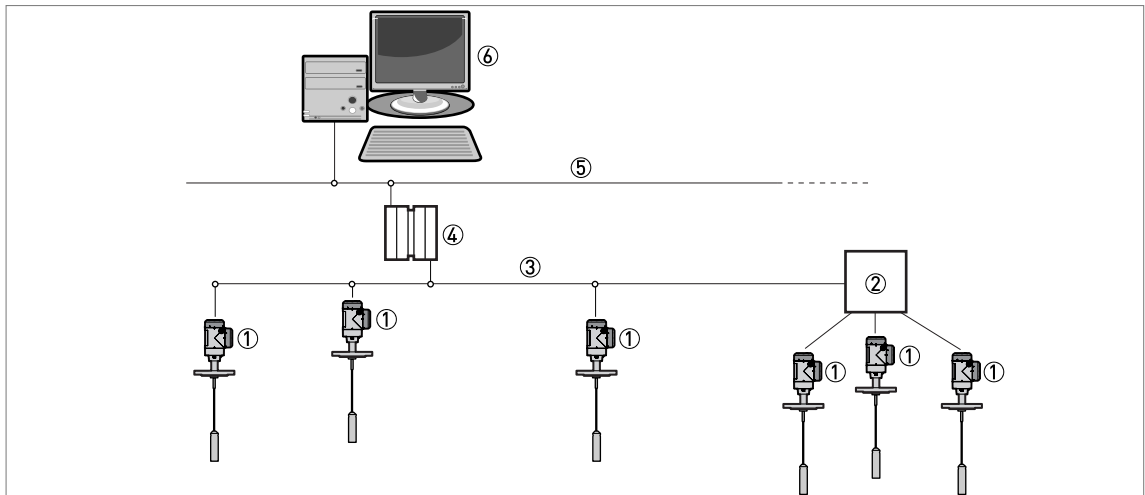

Figure 4-16: FOUNDATION™ fieldbus network (non-Ex)

- ① Field device
- ② Junction box
- ③ H1 network
- ④ H1/HSE converter
- ⑤ High Speed Ethernet (HSE)
- ⑥ Workstation

PROFIBUS PA/DP network (non-Ex)

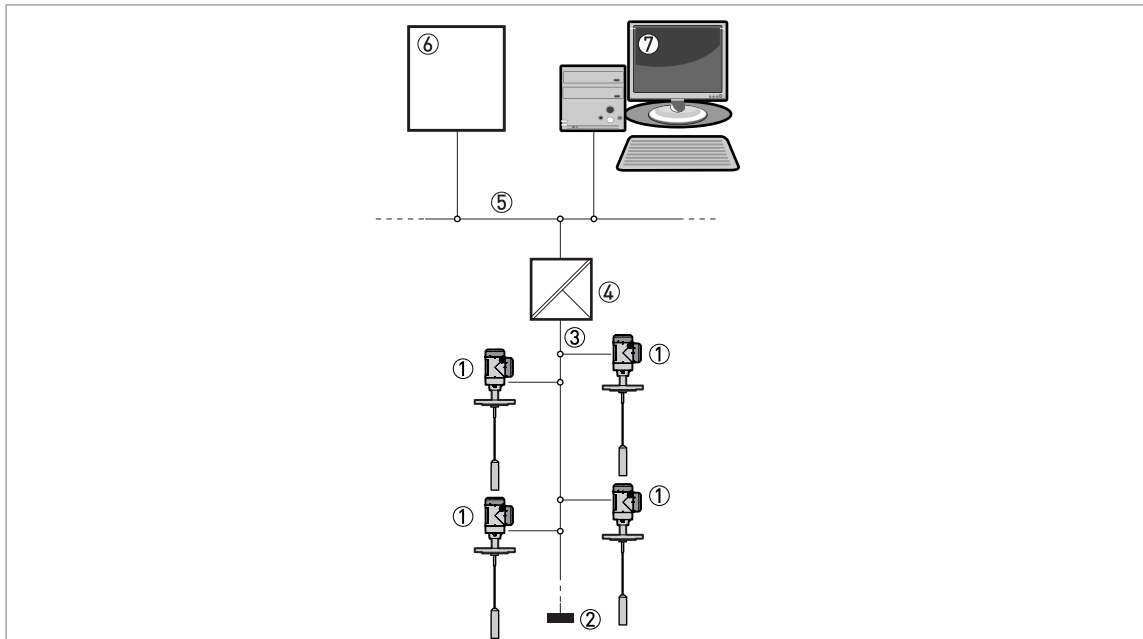

Figure 4-17: PROFIBUS PA/DP network (non-Ex)

- ① Field device
- ② Bus termination
- ③ PROFIBUS PA bus segment
- ④ Segment coupler (PA/DP link)
- ⑤ PROFIBUS DP bus line
- ⑥ Control system (PLC / Class 1 master device)
- ⑦ Engineering or operator workstation (Control tool / Class 2 master device)

5.1 How to start the device

5.1.1 Start-up checklist

Check these points before you energize the device:

- Are all the wetted components (probe, process connection and gaskets) chemically resistant to the product in the tank?
- Does the information on the signal converter nameplate agree with the operating data?
- Did you correctly install the device on the tank?
- Do the electrical connections agree with the national electrical codes?



DANGER!

If the device has a Hazardous Locations approval, make sure that the device and the installation agrees with the requirements of the certificate of compliance.

5.1.2 How to start the device



- Connect the converter to the power supply.
- Energize the converter.
- ➔ **Devices with the LCD display option only:** After 10 seconds the screen will display "Starting up". After 20 seconds the screen will display the software version numbers. After 30 seconds the default screen will appear.
- The device will display readings.



INFORMATION!

This chapter and the start of the chapter that follows tells you what data is given on the device display in normal mode and how to change device settings in configuration mode. If you know about how this device operates, you can ignore this data. Continue with the quick setup procedure. For more data about this procedure, refer to Quick Setup on page 79.

5.2 Operating concept

You can read measurements and configure the device with:

- A digital display screen (optional).
- A connection to a system or PC with PACTware™. You can download the Device Type Manager (DTM) file from the website. It is also supplied on the DVD-ROM delivered with the device.
- A connection to a system or PC with AMS™. You can download the Device Description (DD) file from the website. It is also supplied on the DVD-ROM delivered with the device.
- A connection to a HART® Field Communicator. You can download the Device Description (DD) file from the website. It is also supplied on the DVD-ROM delivered with the device.

5.3 Digital display screen

5.3.1 Local display screen layout

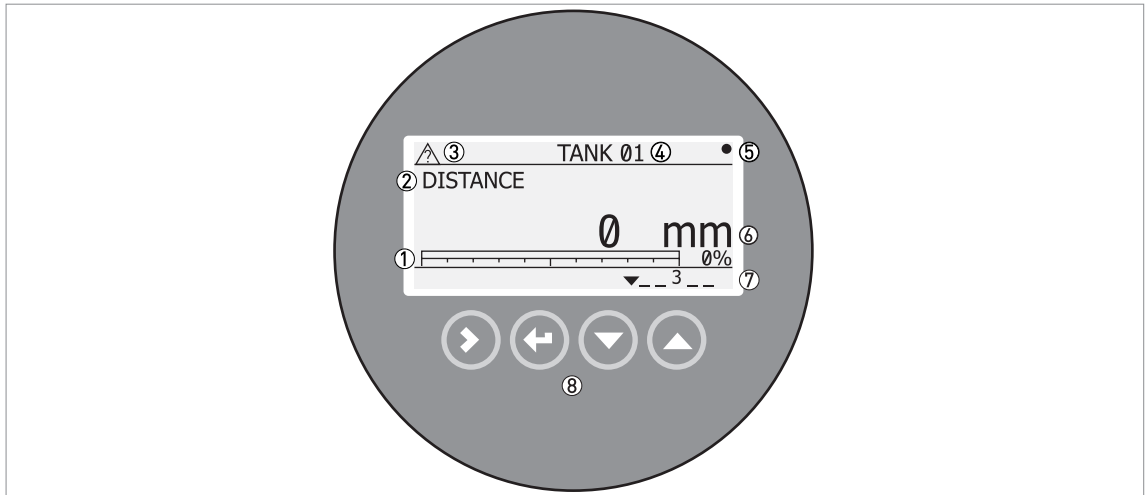

Figure 5-1: Local display screen layout in Normal mode

- ① Current output percentage (bar graph and text — only shown if the current output function is the same as the measurement on the screen in normal mode)
- ② Measurement type (in this example, distance)
- ③ Device status (NE 107 symbols)
- ④ Device tag name
- ⑤ Updated measurement data symbol (the symbol flashes each time the measurement data is updated)
- ⑥ Measurement value and units
- ⑦ Device status (markers)
- ⑧ Keypad buttons (refer to the table in the section that follows)

The current output percentage is only shown if the measurement type (refer to item ② in the illustration) is the same as the output function. The parameter is set in menu item 2.4.1 OUTPUT FUNC.). For example, if the output function is set to "Level" and the device shows "Level" measurements in normal mode, the bar graph and value is shown (refer to item ① in the illustration).



Figure 5-2: Local display screen layout in configuration mode

- ① Function name
- ② Configuration mode symbol
- ③ Menu number

5.3.2 Functions of keypad buttons

Keypad button	Function
[Right]	Normal mode: Enter Information menu (Enter Configuration mode) Configuration mode: Move cursor to the right
[Return / Escape]	Normal mode: Change units (m, cm, mm, in, ft) Configuration mode: Exit
[Down]	Normal mode: Change measurement type (distance, level, output (%), output (mA), conversion, ullage conversion) ① Configuration mode: Decrease value or change parameter
[Up]	Normal mode: Change measurement type (distance, level, output (%), output (mA), conversion, ullage conversion) ① Configuration mode: Increase value or change parameter

- ① If you have made a strapping table in menu item 2.8.1 INPUT TABLE for volume or mass measurement, "Conversion" and "Ullage Conv." will be shown in the list of measurement types

For data on keypad functions, refer to *Normal mode* on page 66.

5.4 Remote communication with PACTware™

PACTware™ displays measurement information clearly and lets you configure the device from a remote location. It is an Open Source, open configuration software for all field devices. It uses Field Device Tool (FDT) technology. FDT is a communication standard for sending information between the system and the field device. This standard agrees with IEC 62453. Field devices are easily integrated. Installation is supported by a user-friendly Wizard.

Install these software programs and equipment:

- Microsoft® .NET Framework version 1.1 or later.
- PACTware.
- HART® converter (USB, RS232...).
- The Device Type Manager for the device.

The software and installation instructions are given on the DVD-ROM supplied with the device 

You can also download the latest version of PACTware™ and the DTM from our website.

 Refer also to the PACTware™ consortium site at <http://www.pactware.de>.

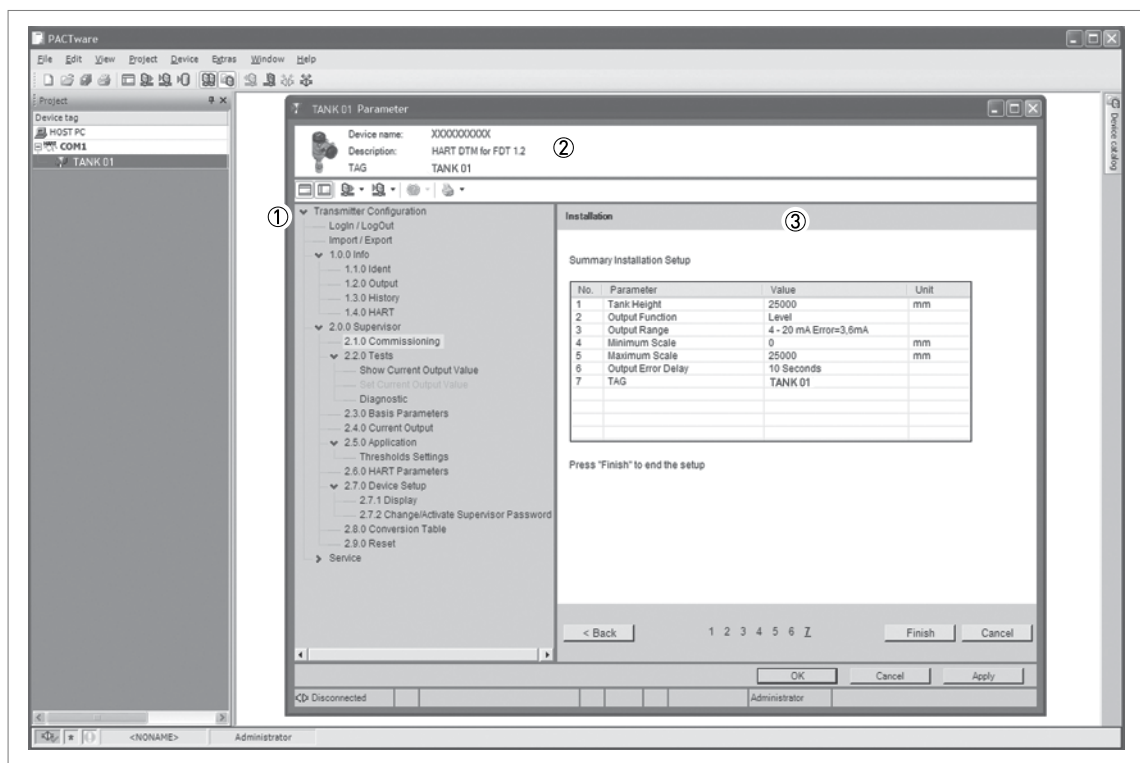

Figure 5-3: Screen from the PACTware™ user interface

- ① DTM menu
- ② Information for device identification
- ③ Configuration summary

5.5 Remote communication with the AMS™ Device Manager

The AMS™ Device Manager is an industrial Plant Asset Management (PAM) software tool. Its role is to:

- Store configuration information for each device.
- Support HART® and FOUNDATION™ fieldbus devices.
- Store and read process data.
- Store and read diagnostic status information.
- Help plan preventive maintenance to reduce a plant's downtime to a minimum.



The DD file is given on the DVD-ROM supplied with the device. You can also download it from our website.

6.1 User modes

Normal mode	This mode displays measurement data. For more data, refer to <i>Normal mode</i> on page 66.
Configuration mode	Use this mode to view parameters, commission the device, create tables for volume or mass measurement, change critical values to measure in difficult process conditions. To get access to supervisor menu, refer to <i>Protection of the device settings</i> on page 82. For more data on menu items, refer to <i>Function description</i> on page 73.





6.2 Normal mode

This mode shows measurement data. Use the table that follows:

- for the selection of the measurement type (level, distance, percentage, conversion) and
- for the selection of the measurement units

Some measurement types will only be available if the device has the correct parameters entered in the configuration mode.

Keypad functions

Button	Description	Function	"Hot key" function
	Right	Enter configuration mode.	-
	Return / Escape	Change the measurement units.	-
	Down	Change the measurement type.	-
	Up	Change the measurement type.	Display language will change to English ①

① The display language will change when you push this button for 2 seconds. Push the button again and it will go back to the original language.

Measurement definitions

Measurement name	Description	Available units
LEVEL	This is a display and an output function option. It is the height from the bottom of the tank to the surface of the liquid or solid contents (Tank height - Distance).	m, cm, mm, in (inches), ft (feet)
DISTANCE	This is a display and an output function option. It is the distance from the face of the flange to the surface of the liquid or solid contents of the tank.	m, cm, mm, in (inches), ft (feet)
CONVERSION	This is a display and an output function option. It gives the volume or mass of the tank contents. This data is available if you prepare a volume or mass table in configuration mode. For data on how to prepare the conversion table, refer to <i>How to configure the device to measure volume or mass</i> on page 84.	kg, t, Ston, Lton, m, cm, mm, in, ft, m3, L, gal, Imp, ft3, bbl
ULLAGE CONV.	This is a display and an output function option. It gives the empty volume or remaining mass that can be put in the tank. This data is available if you prepare a volume or mass table in configuration mode. For data on how to prepare the conversion table, refer to <i>How to configure the device to measure volume or mass</i> on page 84.	kg, t, Ston, Lton, m, cm, mm, in, ft, m3, L, gal, Imp, ft3, bbl
EPSILON R	The dielectric constant of the contents of the tank. An electrical property of the liquid or solid contents of the tank. Also known as ϵ_r , DK and relative permittivity. This gives the strength of the measurement pulse reflection. This data is shown if the menu item AUTO Er CALC (2.5.2) is used to calculate the dielectric constant value.	
OUTPUT I (mA)	The current output of the device.	mA
OUTPUT I (%)	The percentage of the current output. 0% = 4 mA. 100% = 20 mA.	%

6.3 Configuration mode

6.3.1 General notes

Change the settings of your device in **Configuration** mode. Data about the menus is given on page 73. You can:

- Use the **1.0.0 INFORMATION** menu to read settings, device software versions and error records. For more data about the Information menu, refer to Table 1: Info.
- Use the **2.0.0 SUPERVISOR** menu to commission the device, to run diagnostic tests, set up a conversion table for volume or mass measurement, change critical parameters for difficult process conditions, reset the device and change basic parameters (tank height etc.), output settings, HART Address etc. For more data about the Supervisor menu, refer to Table 2: Supervisor.



INFORMATION!

It is not possible to enter the 3.0.0 SERVICE and 4.0.0 MASTER menus. These menus are for factory calibration and approved personnel only.

6.3.2 How to get access to the commissioning menu



Do the steps that follow:

- Push the [>] button.
- ➡ This shows the **Information** menu. The **Information** menu is read only and does not have password security.
- Push the [▲] button one time to scroll up to the **Supervisor** menu.
- ➡ The screen shows the text "2.0.0 SUPERVISOR".
- Push the [>] button one time.
- ➡ The screen shows a line. You must enter the password. Push the buttons under the display screen 6 times (in total and in a given order) to get access to Configuration mode.
- Type in the password. The factory-set password is [>], [←], [▼], [▲], [>] and [←].
- ➡ The device shows the text "2.1.0 COMMISSIONING".



CAUTION!

SIL-approved devices: For data about critical device parameters for SIL approval, refer to the Safety Manual (SIL approval).



INFORMATION!

HOW TO SET THE SUPERVISOR PASSWORD TO "ON" OR "OFF"

The supervisor password is set to "on" by default. If it is necessary to set this function to "off", refer to Function description on page 73, Table 2: Supervisor menu, menu item PSWD YES/NO (2.7.4).



INFORMATION!

HOW TO CHANGE THE SUPERVISOR PASSWORD

You can change the password for the supervisor menu. For more data, refer to Function description on page 73, Table 2: Supervisor menu, menu item PASSWORD (2.7.5).

6.3.3 Menu overview

1.0.0 Info. (Information)

1.1.0	Ident. (Identification)
1.2.0	Output
1.3.0	History

2.0.0 Supervisor

2.1.0	Commissioning
2.2.0	Tests
2.3.0	Basic Parameters
2.4.0	Output I
2.5.0	Application
2.6.0	Communication
2.7.0	Display
2.8.0	Conversion
2.9.0	Config/Reset

3.0.0 Service

n/a	Password locked. Menus for factory calibration and qualified service personnel only.
-----	--

4.0.0 Master

n/a	Password locked. Menus for factory calibration and qualified service personnel only.
-----	--

6.3.4 Keypad functions



Figure 6-1: Local display screen layout in configuration mode

- ① Function name
- ② Configuration mode symbol
- ③ Menu number

This is what you see when you are in Configuration mode. The functions of the buttons are given in the table that follows:

Functions of buttons for menu navigation

Button	Description	Function
	Right	<ul style="list-style-type: none"> Go down to the sub-menu level (for example, from menu 1.0.0 to sub-menu 1.1.0). Enter the menu item
	Enter / Esc (Escape)	<ul style="list-style-type: none"> Go up to the menu level (for example, from sub-menu 1.1.0 to menu 1.0.0). Go to Normal mode. If you changed settings in Configuration mode, you must save or cancel your new settings. For more data, refer to the end of this section.
	Down	<ul style="list-style-type: none"> Scroll down the menu list (for example, from menu 2.0.0 to menu 1.0.0). Scroll down the sub-menu list (for example, from sub-menu 2.2.0 to sub-menu 2.1.0).
	Up	<ul style="list-style-type: none"> Scroll up the menu list (for example, from menu 1.0.0 to menu 2.0.0). Scroll up the sub-menu list (for example, from sub-menu 2.1.0 to sub-menu 2.2.0).

Lists of parameters in menu items

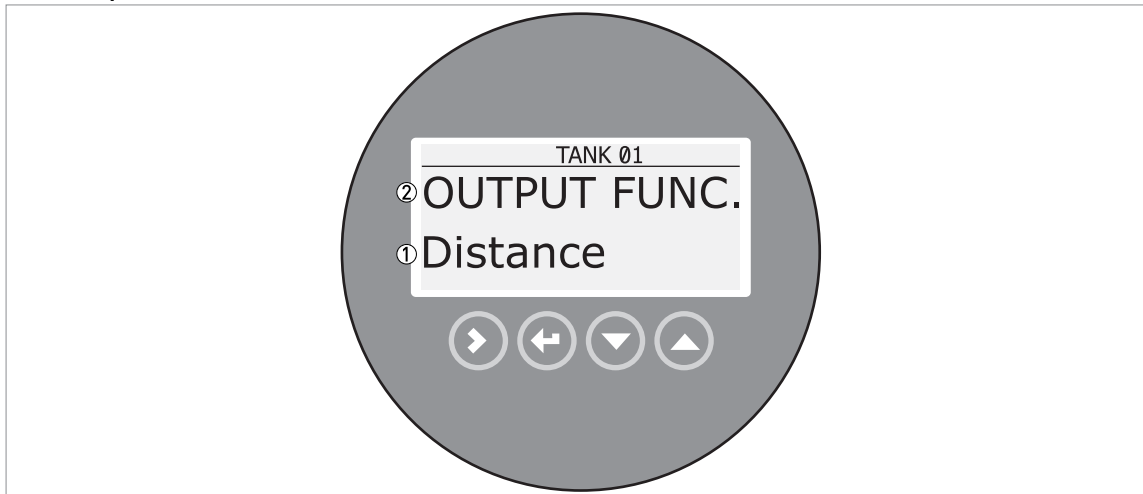





Figure 6-2: Lists of parameters in menu items

- ① Parameter
- ② Menu name

This is what you see when you select a menu item that has a list of parameters. The functions of the buttons are given in the table that follows:

Function of buttons in menu items that have a list of parameters

Button	Description	Function
	Right	n/a
	Enter / Esc (Escape)	Select the parameter and go back to the menu
	Down	Move down the list
	Up	Move up the list

Values in menu items

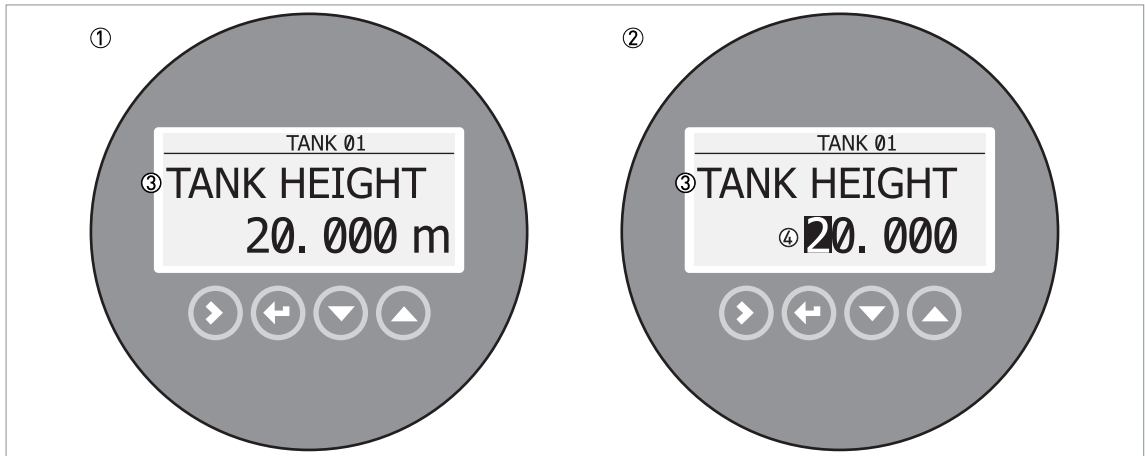

Figure 6-3: Values in menu items

- ① Menu item with values stored at this time (first screen)
- ② Push [➤] again to change the values. A cursor shows on the first digit.
- ③ Menu item name
- ④ Cursor on the selected digit

This is what you see when you select a menu item that has a value. The functions of the buttons are given in the table that follows:

Function of buttons in menu items that have values

Button	Description	Function
	Right	<ul style="list-style-type: none"> Enter the menu item and see the value stored at this time. Enter the menu item configuration level to change the value. Move the cursor to the next digit on the right. If the cursor is on the last digit, push [➤] again to go back to the first digit.
	Enter / Esc (Escape)	Accept the value and go back to the sub-menu.
	Down	Decrease the digit value.
	Up	Increase the digit value.

How to save settings changed in the supervisor menu (menu 2.0.0)



- When you have changed parameters in all the necessary menu items, push [↵] to accept the new parameter.
- Push [↵] to go back to the "STORE" screen.
- The device will ask you to save or cancel your settings. Push [▲] or [▼] to select **STORE YES** or **STORE NO**. Push [↵] to accept or reject the new settings.
- ➡ The display goes back to Normal mode.

6.3.5 Function description

1.0.0 Information (Info.) menu

Menu No.	Function	Function description	Selection list	Default
----------	----------	----------------------	----------------	---------

1.1.0 IDENT.

1.1.1	SERIAL NUM.	The device serial number.	Read only.	
1.1.2	CONV.FIRM.VER	The converter firmware version.	Read only.	
1.1.3	SEN.FIRM.VER	The sensor firmware version.	Read only.	
1.1.4	HMI.FIRM.VER	The HMI (device display screen) firmware version.	Read only.	

1.2.0 OUTPUT I

1.2.1	SUMMARY I	This shows the settings at this time for the output function (OUTPUT FUNC.), output range (RANGE I), 4 mA setting (SCALE 4mA), 20 mA setting (SCALE 20mA), and error delay (ERROR DELAY).	Read only.	
-------	-----------	---	------------	--

1.3.0 HISTORY

1.3.1	ERROR RECORD	A log of device errors. Push [➤] to read the errors. Push [▲] or [▼] to scroll up or down the list. Each error is identified by a code. Push [➤] again to show the number of incidents and the time since the last incident in days, hours, minutes and seconds. For more data about errors, refer to <i>Status and error messages</i> on page 90.	Read only.	
-------	--------------	--	------------	--

2.0.0 Supervisor menu

Menu No.	Function	Function description	Selection list	Default
----------	----------	----------------------	----------------	---------

2.1.0 COMMISSION.

2.1.0	COMMISSION.	This starts a quick set-up procedure applicable to most applications. The supervisor can give the tank height (TANK HEIGHT), output function (OUTPUT FUNC.), current output range (RANGE I), 4 mA setting (SCALE 4mA), 20 mA setting (SCALE 20mA), error delay (ERROR DELAY) and tag name (TAG NAME).		
-------	-------------	---	--	--

2.2.0 TESTS

2.2.1	SET OUTPUT	This sets the analog output to a test value [mA] selected from a list. The output will change to the selected value after 5 seconds, independent of the measured value.	3.5, 4, 6, 8, 10, 12, 14, 16, 18, 20 or 22 mA	3.5 mA
2.2.2	DIAGNOSTIC	This starts the hardware test. Push [➤] many times to show: the time of operation (D1), temperature of the electronic converter board (T1), loop current (I1), load current (I2), voltage 5.6 V (V1), voltage on capacitors (V2), voltage 3.3 V (V3), amplitude reference pulse (P1), amplitude level pulse (P2), amplitude probe end pulse (P3), reset counter (C1). If you push [➤] again, the display goes back to the menu level.		

2.3.0 BASIC PARAM.

2.3.1	TANK HEIGHT	The distance from the tank connecting flange face / thread stop down to the tank bottom.	min-max: 0...80 m / 0...262.48 ft	If tank height is not specified in customer order, the probe length value is used as an alternative
2.3.2	TIME CONST.	Increasing the time constant will smoothen the integrated readings, decreasing will roughen the readings.	min-max: 0 to 100 seconds	5 seconds
2.3.3	PROBE LENGTH	Probe length is the distance from the flange face / thread stop of the device down to the bottom end of the probe (including counterweight for cable versions). If probe length has been modified, enter the new value here. For more data, refer to <i>How to decrease the length of probes</i> on page 88.	min: 2.3.4 BLOC. DIST. + 3.1.1 COUNTERWEIGHT max.: 40 m / 131.23 ft	This value is given in customer order
2.3.4	BLOC. DIST.	Blocking distance. The non-measuring range at the top of the probe. It depends on the probe type and the installation.	min: 0 m / 0 ft max: 2.3.3 PROBE LENGTH	50 mm / 1.97"
2.3.5	TAG NAME	The device has a code (tag name) to identify it. If the tag name is given in the customer order data, it will be set at the factory. A maximum of 8 characters can be used.	?	TANK 01

Menu No.	Function	Function description	Selection list	Default
----------	----------	----------------------	----------------	---------

2.4.0 OUTPUT I

2.4.1	OUTPUT FUNC.	The output function. Select an output function to scale the current values in relation to a given point (usually the device process connection or the tank bottom). The output current value is shown on a bar graph in normal mode if the measurement name (displayed measurement) is the same as the output function. Conversion parameters (Distance Conversion, Level Conversion) are shown if there is volume or mass data in 2.8.1 INPUT TABLE.	Distance, Level, Distance conversion, Level conversion	Level
2.4.2	RANGE I	This menu item sets the limits of the output current range to 1 of the 2 available options: standard limits (4...20 mA) or NAMUR NE 43-compliant limits (3.8...20.5 mA). It also tells the device what to do if an error occurs. If you set RANGE I to 4-20/22E and an error occurs (e.g. the tank is too full, ...), the device output current will change to an error value of 22 mA. If you set RANGE I to 4-20 and the device senses a measurement error, the value will stop at the last correct measurement.	4-20, 4-20/22E, 4-20/3.6E, 3.8-20.5/22E, 3.8-20.5/3.6E	4-20/3.6E (If the device is used in safety-related systems (SIL2), do not use the "4-20" setting)
2.4.3	SCALE 4mA	This gives a measurement value to 4 mA.	min-max: ①	This depends on the probe type ②
2.4.4	SCALE 20mA	This gives a measurement value to 20 mA.	min-max: ①	This depends on the probe type ②
2.4.5	ERROR DELAY	The time after which the current output changes to an error value. The error value shows that there is a measurement error. MN=minutes and S=seconds.	0 S, 10 S, 20 S, 30 S, 1 MN, 2 MN, 5 MN, 15 MN	1 MN

2.5.0 APPLICATION

2.5.1	TRACING VEL.	Tracing velocity. This value must agree with the maximum rate of change of the level of the liquid or solid contents in the tank.	min-max: 0.1...1000 m/min	10.0 m/min
2.5.2	AUTO Er CALC	Automatic dielectric constant (ϵ_r) calculation. For measurement in TBF mode. The device automatically calculates the ϵ_r value of the liquid or solid contents in the tank.	YES, NO	NO
2.5.3	GAS EPS. R	Dielectric constant (ϵ_r) of the gas in the tank. A major parameter for TDR level measurement devices. If the dielectric constant of the gas is very different from the default value (air), set 2.5.3 GAS EPS. R to the ϵ_r value of the gas.	min-max: 0.8...115.00	1
2.5.4	EPS.R CALCUL.	The calculated ϵ_r value for the liquid or solid contents in the tank. The result of the calculation in 2.5.2 AUTO EPSI. R. This menu item will not be available if 2.5.2 AUTO EPSI. R is not used.	Read only.	

Menu No.	Function	Function description	Selection list	Default
2.5.5	PROD. EPS. R	Dielectric constant (ϵ_r) of the the liquid or solid contents in the tank. If possible, type in the exact value of the product's dielectric constant. If you do not know the exact value, use 2.5.2 AUTO Er CALC. A new product ϵ_r that is too low will mean that level will read higher than its true value. This menu item is only used in TBF mode.	min-max: 1.0 to 115.00	2.4
2.5.6	MEAS. AMP.	Measured pulse amplitude. This is the amplitude of the signal (after reflection on the surface of the tank contents) compared with the amplitude of the reference pulse. This value helps you to set the measurement threshold in menu item 2.5.7 MEAS. THRESH. For more data, refer to <i>Thresholds and parasitic signals</i> on page 86.		
2.5.7	MEAS. THRESH.	Measurement threshold. If it is difficult to identify the level signal (for example: too many parasite signals), you can increase the threshold. This value is measured in thousandths (1...1000). A threshold of 100 is equivalent to 10% of the amplitude of the reference pulse at a distance of 1 m / 3.3 ft from the thread stop. For more data, refer to <i>Thresholds and parasitic signals</i> on page 86.	min-max: 0 to 1000	60
2.5.8	PROBE END AMP	Probe end pulse amplitude. This is the amplitude of the signal (after reflection at the bottom of the probe) compared with the amplitude of the reference pulse. This value helps you to set the measurement threshold in menu item 2.5.9 PROBE END AMP. For more data, refer to <i>Thresholds and parasitic signals</i> on page 86.		
2.5.9	PROBE END TH.	Probe end threshold. For measurement in TBF mode. If it is difficult to identify the probe end signal (for example: too many parasite signals), you can increase the threshold of the signal. A threshold of 100 is equivalent to 10% of the amplitude of the reference pulse at a distance of 1 m / 3.3 ft from the thread stop. For more data, refer to <i>Thresholds and parasitic signals</i> on page 86.	min-max: 0 to 1000	50

2.6.0 COMMUNICATION

2.6.1	HART ADDRESS	Any HART® address greater than 0 will activate HART® multidrop mode. The current output stays constant at 4 mA. If 2.6.1 HART ADDRESS is set to 0, the device will operate in point-to-point mode.	min-max: 0...15	0
-------	--------------	--	-----------------	---

Menu No.	Function	Function description	Selection list	Default
----------	----------	----------------------	----------------	---------

2.7.0 DISPLAY

2.7.1	LANGUAGE	Data can be shown in any of the languages stored in the device.	9 languages are available in 3 packs: (1) English, French, German and Italian; (2) English, French, Spanish and Portuguese; (3) English, Chinese (Simplified), Japanese and Russian	③
2.7.2	LENGTH UNIT	The length unit of measurement shown in normal mode.	m, cm, mm, in (inches), ft (feet)	m
2.7.3	CONV UNIT	Conversion unit. The length, volume or mass conversion unit for the conversion table and shown in normal mode.	kg, t, Ston, Lton, m, cm, mm, in, ft, m3, L, gal, Imp, ft3, bbl	kg
2.7.4	PSWD YES/NO	If it is necessary to protect your settings in the supervisor menu with a password, set this menu item to YES .	YES, NO	YES
2.7.5	PASSWORD	This changes the password for the supervisor menu. Push the buttons up to 6 times in any order. This will be the new password. To confirm the change, enter the new password a second time. For more data, refer to <i>Protection of the device settings</i> on page 82.		[>], [←], [▼], [▲], [>] and [↶]
2.7.6	CONTRAST	The contrast control for the display screen. You can select a shade of grey between light grey (level 20) and black (level 54).	min-max: 20...54	36

2.8.0 CONV. TABLE

2.8.1	INPUT TABLE	The device uses a conversion table (strapping table) to convert measurements to volume and mass readings. The readings are shown in normal mode. Go to this menu item and enter the entry number (01...30). Then enter the level and the related volume / mass / flow rate value for that entry. Push [←] to confirm the entry values. Continue the procedure until the device has data for all the entries. For more data, refer to <i>How to configure the device to measure volume or mass</i> on page 84.	min. 2 entries max. 30 entries (level / volume or mass)	0 entries
2.8.2	DELETE TABLE	This menu item erases the data in the conversion table.	YES, NO	NO

2.9.0 CONFIG/RESET

2.9.1	SAVE	This menu item is not available.	YES, NO	NO
2.9.2	RECALL	This menu item is not available.	YES, NO	NO
2.9.3	RESTART	This menu item starts the device again.	YES, NO	NO
2.9.4	RESET FACT.	If you set this menu item to "YES", the device goes back to its initial settings (set by the manufacturer in the factory).	YES, NO	NO

① Units and range depend on the output function, length unit and volume unit selected

② Refer to the table that follows (Default values for menu items 2.4.3 SCALE 4mA and 2.4.4 SCALE 20mA)

③ If the device has the LCD display option, this depends on data given in the customer order

Default values for menu items 2.4.3 SCALE 4mA and 2.4.4 SCALE 20mA

Probe type	SCALE 4mA		SCALE 20mA	
	[mm]	[inches]	[mm]	[inches]
Ø2 mm / 0.08" Single cable	250	9.84	L - 300 ①	L - 11.81 ①
Ø4 mm / 0.16" Single cable	200	7.87	L - 300 ①	L - 11.81 ①
Single rod	170	6.69	L - 300 ①	L - 11.81 ①
Coaxial	50	1.97	L - 200 ①	L - 7.87 ①
Ø4 mm / 0.16" double cable	100	3.94	L - 250 ①	L - 9.84 ①
Ø8 mm / 0.31" double rod	110	4.33	L - 270 ①	L - 10.63 ①

① L, Probe length

3. Service menu

Menu No.	Function	Function description	Selection list	Default
3.0.0	SERVICE	Advanced settings. The settings in this menu are protected with a password. Only approved personnel can change the parameters in this menu. For more data, contact your local sales office.		

4. Master menu



Menu No.	Function	Function description	Selection list	Default
4.0.0	MASTER	Factory settings. The settings in this menu are protected with a password. Only approved personnel can change the parameters in this menu. For more data, contact your local sales office.		



6.4 Further information on device configuration

6.4.1 Quick Setup

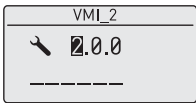
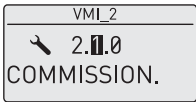
Use this procedure to change the probe length and give the top and bottom measuring limits. « xx » in the illustrations shows that you can change the value or the parameter. Push the keypad buttons in the correct sequence:

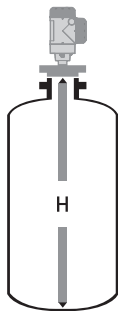
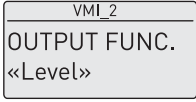
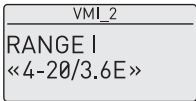
Procedure

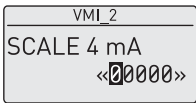
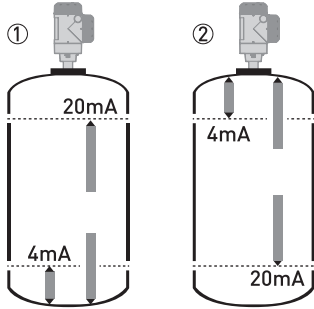
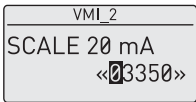
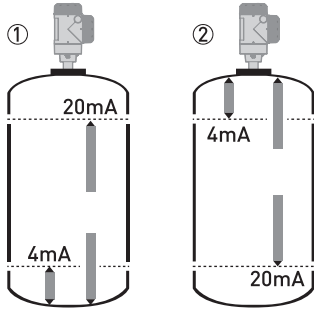
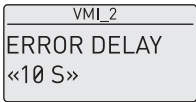
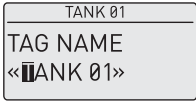
Screen	Steps	Description
	<ul style="list-style-type: none"> [>], [▲] and [>]. 	Default screen. Enter configuration mode (2.0.0 SUPERVISOR).
	<ul style="list-style-type: none"> [>], [←], [▼], [▲], [>] and [←]. 	Enter the password (the default password is shown). If it is necessary to change the password, refer to <i>Function description</i> on page 73, menu item 2.7.5 PASSWORD.
	<ul style="list-style-type: none"> [>] 	Push this button to start the quick set-up procedure.
	<ul style="list-style-type: none"> [>] to change the tank height (H). [>] to change the position of the cursor. [▼] to decrease the value or [▲] to increase the value. [←] to confirm. 	
	<ul style="list-style-type: none"> [▲] or [▼] for the selection of the measurement name (Distance, Level, Conversion or Ullage Conv.). [←] to confirm. 	The manufacturer sets the output function to "Level" before delivery. If it is necessary to measure volume, ullage volume, mass or ullage mass (Conversion or Ullage Conv.), refer to <i>How to configure the device to measure volume or mass</i> on page 84.
	<ul style="list-style-type: none"> [▲] or [▼] for the selection of the current output range (4-20 mA/3.6E, 4-20, 3.8-20.5/3.6E, etc.). [←] to confirm. 	

Screen	Steps	Description
	<ul style="list-style-type: none"> • [➤] to change Scale 4 mA. • [➤] to change the position of the cursor. • [▼] to decrease the value or [▲] to increase the value. • [↵] to confirm. 	<p>Use this step to give the 4 mA output setting (0% limit) in the tank. Refer to the illustrations that follow. Illustration ① shows the settings for level. Illustration ② shows the settings for distance.</p> 
	<ul style="list-style-type: none"> • [➤] to change Scale 20 mA. • [➤] to change the position of the cursor. • [▼] to decrease the value or [▲] to increase the value. • [↵] to confirm. 	<p>Use this step to give the 20 mA output setting (100% limit) in the tank. Refer to the illustrations that follow. Illustration ① shows the settings for level. Illustration ② shows the settings for distance.</p> 
	<ul style="list-style-type: none"> • [▲] or [▼] for the selection of the error delay (0 s, 10 s, 20 s, 30 s, 1 mn, 2 mn, 5 mn or 15 mn). • [↵] to confirm. 	<p>The time after which the current output changes to an error value. The error value shows that there is a measurement error.</p>
	<ul style="list-style-type: none"> • [➤] to change the tag name. • [➤] to change the position of the cursor. • [▼] to decrease the alphanumeric value [A, B, ..., 1, 2, ...] or [▲] to increase the alphanumeric value. • [↵] to confirm. 	
	<ul style="list-style-type: none"> • 2 × [↵] to confirm. • [▲] or [▼] for the selection of the save option (STORE NO or STORE YES). • [↵] to confirm. 	<p>Set to STORE YES to save and use the data. Set to STORE NO to cancel the changes to the device settings.</p>

6.4.2 Test

Use this procedure to test the loop current. « xx » in the illustrations shows that you can change the value or the parameter. Push the keypad buttons in the correct sequence:

Procedure

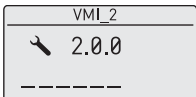
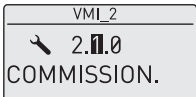
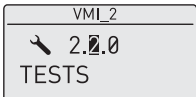
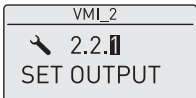
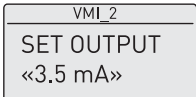
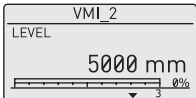
Screen	Step	Description
		Default screen.
	<ul style="list-style-type: none"> [>], [▲] and [>]. 	
	<ul style="list-style-type: none"> Enter the password: [>], [←], [▼], [▲], [>] and [←]. [←] 	
	<ul style="list-style-type: none"> [▲]. 	
	<ul style="list-style-type: none"> [>]. 	
	<ul style="list-style-type: none"> [>]. [▼] to decrease the value or [▲] to increase the value. [←] to confirm. 	This step sets the loop current value. Make a selection from 3.5, 4, 6, 8, 10, 12, 14, 16, 18, 20 or 22 mA.
	<ul style="list-style-type: none"> [←] 3 times to go back to the default screen. 	The loop current goes back to initial value. Default screen.

6.4.3 Protection of the device settings

The menu item PASSWORD (2.7.5) lets you change the supervisor menu password.



How to change the supervisor menu password

- After you enter the supervisor menu, push 6 × [▲], [▶] and 4 × [▲] to go to the menu item PASSWORD (2.7.5).
- Enter the new 6-character password (push the 4 buttons in any sequence).
- Enter the new 6-character password again.
- ➡ If the second entry is the same as the first, the device will go back to the sub-menu list (2.7). If the second entry is not the same as the first, the device will not go back to the sub-menu list. Push [←] to start the password sequence again and enter the new 6-character password 2 times.
- Push [←] to go back to the "STORE" screen.
- Push [▲] or [▼] to set the screen to **STORE YES** and push [←].
- ➡ The device will save the new password and go back to normal mode.



INFORMATION!

Make a note of the password and keep it in a safe place. If you lose the password, please contact your supplier.

How to set the supervisor password to "on" or "off"

The supervisor password is set to "on" by default. If it is necessary to set this function to "off", refer to *Function description* on page 73, Table 2: Supervisor menu, menu item PSWD YES/NO (2.7.4).

6.4.4 HART[®] network configuration



INFORMATION!

For more data, refer to Networks on page 57.

The device uses HART[®] communication to send information to HART[®]-compatible equipment. It can operate in either point-to-point or multidrop mode. The device will communicate in multidrop mode if you change the address.



CAUTION!

Make sure that the address for this device is different from others in the multidrop network.



How to change from point-to-point to multidrop mode

- Enter the supervisor menu.
- Push [▶], 5 × [▲] and [▶] to go to menu item ADDRESS (2.6.1).
- Push [▶] to change the value. Enter a value between 1 and and push [←] to confirm (refer to the caution before this procedure).
- Push [←] to go back to the "STORE" screen.
- Push [▲] or [▼] to set the screen to **STORE YES** and push [←].
- ➡ The output is set to multidrop mode. The current output is set to 4 mA. This value does not change in multidrop mode.



How to change from multidrop to point-to-point mode

- Enter the supervisor menu.
- Push [➤], 5 × [▲] and [➤] to go to menu item ADDRESS (2.6.1).
- Push [➤] to change the value. Enter the value 0 and push [⬅] to confirm.
- Push [⬅] to go back to the "STORE" screen.
- Push [▲] or [▼] to set the screen to **STORE YES** and push [⬅].
- ➡ The output is set to point-to-point mode. The current output changes to a range of 4...20 mA or 3.8...20.5 mA (this range is set in menu item RANGE I (2.4.2)).

6.4.5 Distance measurement

The device current output agrees with the distance measurement when the output is set to "Distance". Menu items used for distance measurement are:

- Output Function (2.4.1 OUTPUT)
- Tank Height (2.3.1 TANK HEIGHT)
- Blocking Distance (2.3.4 BLOC. DIST.)

Use the flange facing or thread stop as the reference point for the 4 and 20 mA current output settings. The 4 and 20 mA current output settings are the minimum and maximum points of the measurement scale.

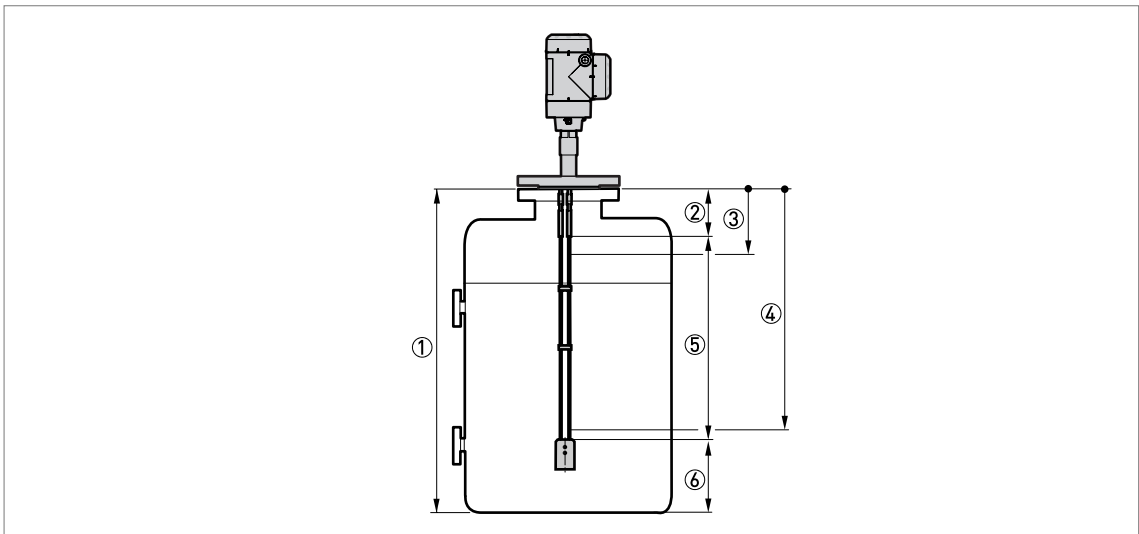

Figure 6-4: Distance measurement

- ① Tank Height (2.3.1 TANK HEIGHT)
- ② Blocking Distance (2.3.4 BLOC. DIST.)
- ③ 4 mA Setting (2.4.3 SCALE 4mA)
- ④ 20 mA Setting (2.4.4 SCALE 20mA)
- ⑤ Maximum effective measuring range
- ⑥ Non-measurement zone

For more data about the menu items, refer to *Function description* on page 73.

6.4.6 Level measurement

The device current output agrees with the level measurement when the output is set to "Level". Menu items related to level measurement are:

- Output Function (2.4.1 OUTPUT)
- Tank Height (2.3.1 TANK HEIGHT)
- Blocking Distance (2.3.4 BLOC. DIST.)

Use the tank bottom as the reference point for the 4 and 20 mA current output settings. The 4 and 20 mA current output settings are the minimum and maximum points of the measurement scale.

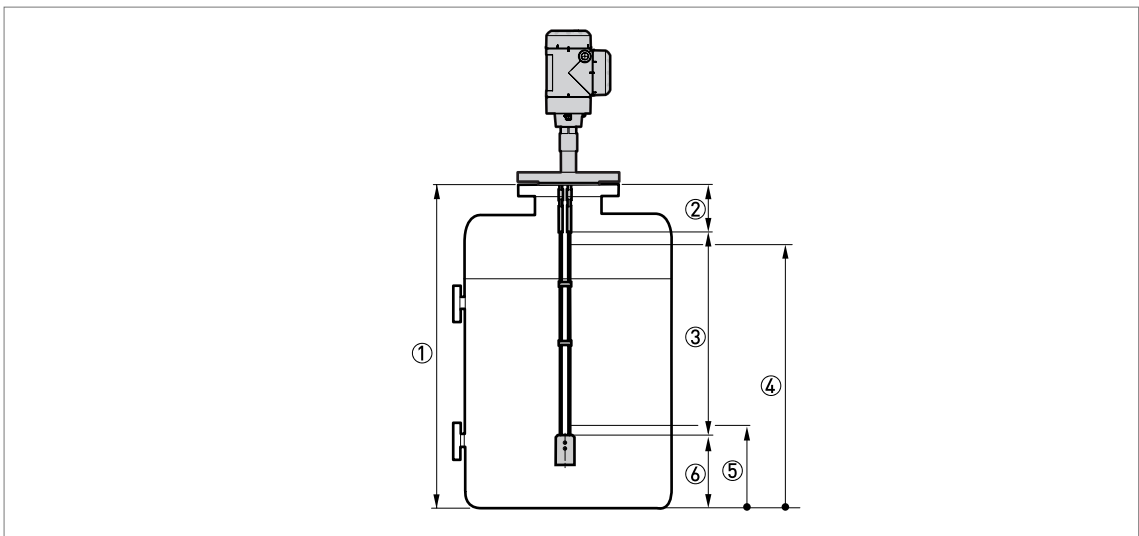

Figure 6-5: Level measurement

- ① Tank Height (2.3.1 TANK HEIGHT)
- ② Blocking Distance (2.3.4 BLOC. DIST.)
- ③ Maximum effective measuring range
- ④ 20 mA Setting (2.4.4 SCALE 20mA)
- ⑤ 4 mA Setting (2.4.3 SCALE 4mA)
- ⑥ Non-measurement zone

For more data about the menu items, refer to *Function description* on page 73.

6.4.7 How to configure the device to measure volume or mass

The device can be configured to measure volume or mass. You can set up a strapping table in the conversion table (2.8.0 CONV. TAB) sub-menu. Each entry is a pair of data (level - volume or level - mass). The strapping table must have a minimum of 2 entries and a maximum of 30. The reference point for the table is the bottom of the tank (as given in menu item 2.3.1 TANK HEIGHT).



CAUTION!

Enter the data in numerical sequence (strapping table entry number 01, 02, ...).



How to prepare a strapping table.

- Enter the supervisor menu.
- Push [➤], 6 × [▲], [➤] and [▲] to go to 2.7.2 LENGTH UNIT.
- Push [▲] and [▼] to find the length unit that you will use in the table.
- Push [↵] to go to the sub-menu level.
- Push [▲] to go to 2.7.3 CONV UNIT (conversion unit)
- Push [▲] and [▼] to find the conversion unit that you will use in the table.
- Push [↵] to go to the sub-menu level and then [▲] and [➤] to go to the menu item 2.8.1 INPUT TAB
- Push [➤] to make the strapping table. Enter the table entry number (01).
- Enter the length value and push [↵].
- Enter the conversion value and push [↵].
- Push [➤] to enter the subsequent table entry number (02, 03, ..., 30).
- Repeat the last 3 steps to complete the table.
- Push [↵] to go back to the "STORE" screen.
- Push [▲] or [▼] to set the screen to **STORE YES** and push [↵].
- ➡ The device will store the data for the strapping table and go back to normal mode.

The device will give more accurate volume readings if you give more conversion data in these areas:

- Surfaces with curves.
- Sudden changes in the cross section.

Refer also to the illustration that follows:

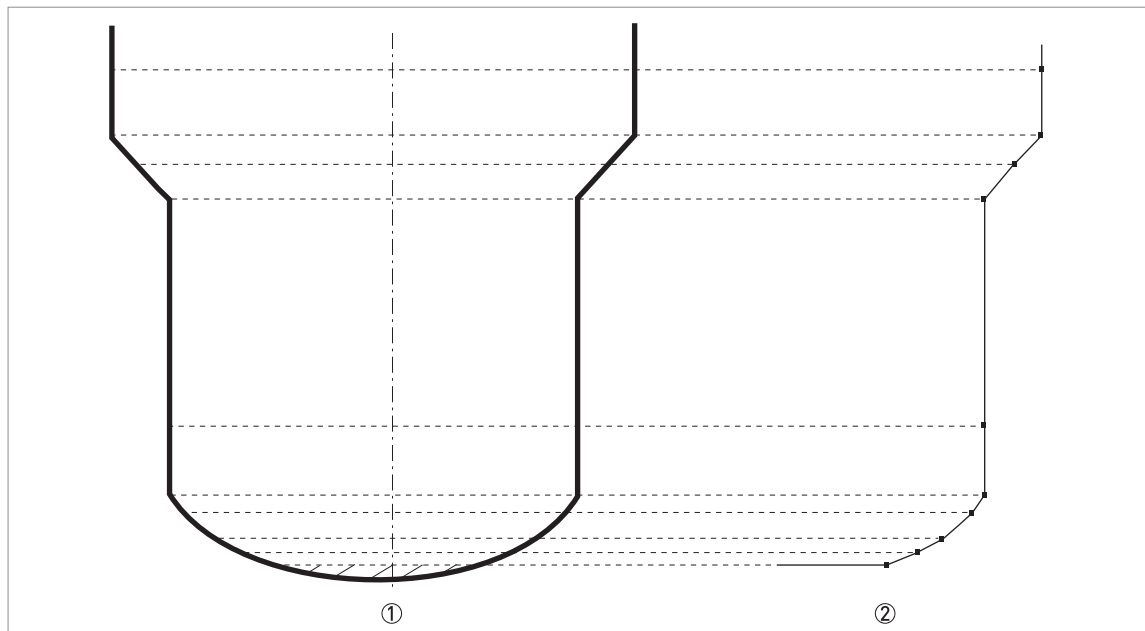

Figure 6-6: A plot of points for a volume or mass table

- ① Tank with reference points
- ② Tank model with plotted points



How to delete a volume or mass table.

- Enter the supervisor menu.
- Push 7 × [▲], [>], and [▲] to go to 2.8.2 DELETE TABLE.
- Push [>] and [▲] to set the parameter to **YES**.
- Push [←] to go back to the "STORE" screen.
- Push [▲] or [▼] to set the screen to **STORE YES** and push [←].
- ➡ The device will delete the data for the strapping table and go back to normal mode. The "CONVERSION" and "ULLAGE CONV." data are not available in normal mode.

6.4.8 Thresholds and parasitic signals

General notes

The low-power electromagnetic signal from the device goes down the probe. The surface of the liquid or solids, and objects in the tank, make reflections. These reflections go back up the probe to the signal converter. The signal converter changes the reflections into voltage amplitudes. Reflections from objects in the tanks are interference signals (parasitic signals).

How thresholds work

Thresholds let the device ignore reflections with small amplitudes and monitor changes in level.

The device uses the menu items that follow:

- **Direct mode only:** 2.5.7 MEAS. THRESH. (measurement threshold) to set the threshold for the reflection on the surface of the liquid or solids.
- **TBF mode only:** 2.5.9 PROBE END TH. (probe end threshold) to set the threshold for the reflection on the end of the probe. If the device operates in TBF mode or must calculate the ϵ_r of the product, there must be a good probe end signal.

The user can do a check of the signal amplitude after reflection on the surface of the liquid or solids:

- 2.5.6 MEAS. AMP. (measured pulse amplitude). This is the signal amplitude (after reflection on the liquid or solids in the tank) compared with the reference pulse amplitude. It is measured in thousandths (1...1000) of the reference pulse amplitude (value= 1000). The device measures the distance from the process connection to the level signal, and the signal amplitude. The signal converter then does a mathematical conversion (that agrees with a law of signal attenuation) to show the signal amplitude at a standard distance of 1 m / 3.3 ft from the process connection. This value helps you to set the measurement threshold in menu item 2.5.7 MEAS. THRESH.
- 2.5.8 PROBE END AMP (probe end amplitude). This is the signal amplitude (after reflection on the probe end) compared with the reference pulse amplitude. This value is measured in thousandths (1...1000) of the reference pulse amplitude (value= 1000). The device measures the distance from the process connection to the level signal, and the signal amplitude. The signal converter then does a mathematical conversion (that agrees with a law of signal attenuation) to show the signal amplitude at a standard distance of 1 m / 3.3 ft from the process connection. This value helps you to set the measurement threshold in menu item 2.5.9 PROBE END TH.



INFORMATION!

For more data on menu items, refer to Function description on page 73.

How to use thresholds



INFORMATION!

- Although the data that follows refers to the level threshold, it is applicable for the probe end threshold.
- If there is a parasitic signal above the level and the threshold is too low, the device can incorrectly use it as the level signal.

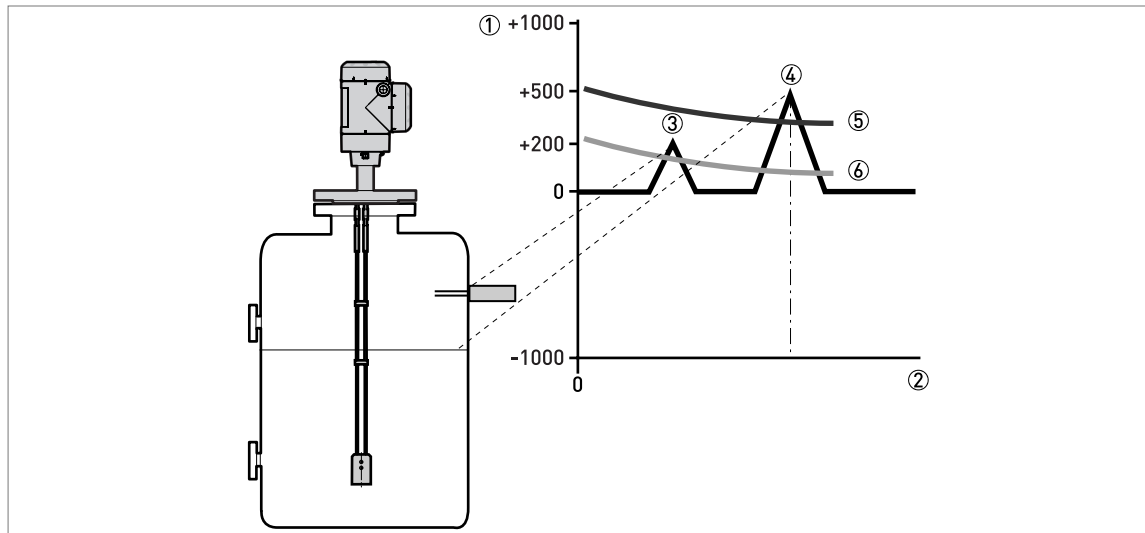

Figure 6-7: Signal intensity/distance graph: thresholds

- ① Signal intensity given as a fraction of the reference pulse (measured in thousandths)
- ② Distance from the process connection
- ③ Parasitic signal. A signal from a level switch that is in the limits of the electromagnetic field around the probe.
- ④ Level signal of the liquid or solids
- ⑤ The level threshold is correct. The device ignores the parasitic signal and measures level correctly.
- ⑥ The level threshold is too low. The device can use the parasitic signal as the level signal.



If the parasitic signal is smaller than the correct level, you can manually change the threshold to find the signal. This procedure tells you how to change the level threshold to find the correct signal:

- Look at the menu item 2.5.6 MEAS. AMP.
- ➡ Make a note of the amplitude of the correct level signal.
- Go to 2.5.7 MEAS. THRESH.
- Increase the amplitude of the level threshold.
- ➡ This value must be more than the incorrect signal. We recommend that you set the level threshold at half the amplitude of the correct signal.
- Save the settings.
- ➡ The threshold increases. It ignores the parasite signal and uses the first signal it finds.

Probe end threshold

When the device operates in TBF mode, the probe end threshold value can be changed. The device uses TBF mode to measure the level of products with low dielectric constants. It uses the probe end as a reference. If the reflection is very weak, change the probe end threshold to ignore parasitic signals. Refer to the procedure in **How to use thresholds** to change the probe end threshold.

For more data about the probe end threshold, refer to *Function description* on page 73 (menu item 2.5.9).

6.4.9 How to decrease the length of probes



INFORMATION!

This information is for the probe types that follow:

- $\varnothing 4$ mm / 0.16" double cable
- $\varnothing 8$ mm / 0.31" single rod
- $\varnothing 2$ mm / 0.08" single cable
- $\varnothing 4$ mm / 0.16" single cable



How to decrease the length of single rod probes

- Measure the length of the rod from the flange facing or thread stop. Use a scribe to put a mark on the rod.
- Cut the rod to the correct length.
- Enter the supervisor menu.
- Push [➤], 2 × [▲], [➤] and 2 × [▲] to go to menu item 2.3.3 PROBE LENGTH.
- Enter the new value. Push [←] to go back to the sub-menu level.
- Push 4 × [←] to save settings.
- Set the parameter to STORE YES and push [←].



How to decrease the length of cable probes

- Loosen the socket set screws that hold the counterweight with a 3 mm Allen wrench.
- Remove the counterweight.
- Measure the length of the cable from the flange facing or thread stop. Use a scribe to put a mark on the cable.
- ➡ Add the length of the counterweight and subtract the length of the cable engaged in the counterweight. This gives the total probe length. Refer to the illustration and table that follows.
- Cut the cable to the correct length.
- Attach the cable to the counterweight. Tighten the socket set screws with a 3 mm Allen wrench.
- Enter the supervisor menu.
- Push [➤], 2 × [▲], [➤] and 2 × [▲] to go to menu item 2.3.3 PROBE LENGTH.
- Enter the new value. Push [←] to go back to the sub-menu level.
- Push 4 × [←] to save settings.
- Set the parameter to STORE YES and push [←].

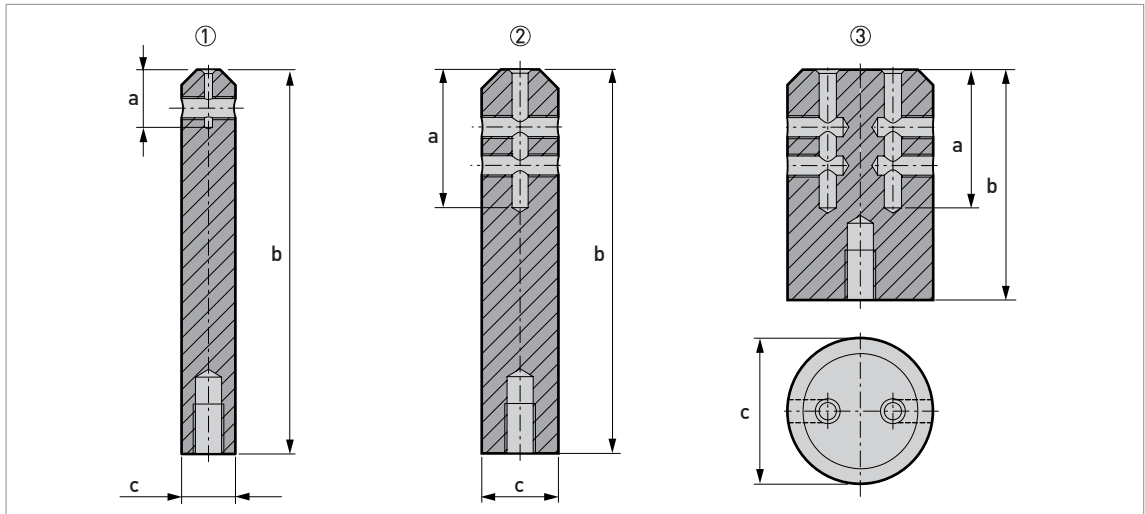

Figure 6-8: Dimensions of the counterweights

- ① Ø2 mm / 0.08" single cable probe
- ② Ø4 mm / 0.15" single cable probe
- ③ Ø4 mm / 0.15" double cable probe

Dimensions in mm

Probe type	Dimensions [mm]		
	a	b	Øc
Single cable Ø2 mm	15	100	14
Single cable Ø4 mm	36	100	20
Double cable Ø4 mm	36	60	38

Dimensions in inches

Probe type	Dimensions [inches]		
	a	b	Øc
Single cable Ø0.08"	0.6	3.9	0.5
Single cable Ø0.15"	1.4	3.9	0.8
Double cable Ø0.15"	1.4	2.4	1.5

6.5 Status and error messages

6.5.1 Device status (markers)

If the device senses a change in device status, the display screen will show 1 or more status markers at the bottom right side of the display screen. The display screen will also show a symbol that agrees with NAMUR Recommendation NE 107 (Self-Monitoring and Diagnosis of Field Devices) and VDI/VDE 2650. This is shown at the top left side of the display screen. More data is given if you use PACTware™ software with the appropriate DTM on a PC. Error codes and data are shown on the device display screen and in the DTM.

Menu item 2.2.2 DIAGNOSTIC (Configuration mode / Supervisor menu) supplies more data. This includes internal voltages, the loop current and the reset counter (watchdog timer). You can see this data on the device display screen and in the DTM.

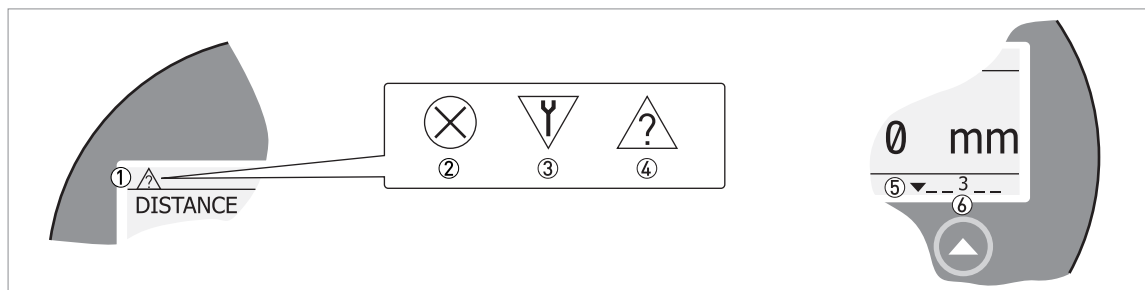





Figure 6-9: Status markers

- ① Device status (NAMUR NE 107 symbols)
- ② Symbol: Failure
- ③ Symbol: Function check
- ④ Symbol: Out of specification
- ⑤ Status marker line (marker 3 is shown)
- ⑥ When the status marker is on, a number is shown

Types of error message

NE 107 status	Type of error	Description
Failure	Error	If an error message is shown in ERROR RECORD (menu item 1.3.1), the current output goes to the error signal value set in menu item RANGE I (menu item 2.4.2) after the time set in ERROR DELAY (menu item 2.4.5). For more data about menu items, refer to <i>Function description</i> on page 73.
Out of specification	Warning	If a warning message is shown, there is no effect on the current output value.

NE 107 symbol shown	NE 107 Status	Description	Status marker shown	Error code (Type)	Possible errors
	Failure	The device does not operate correctly. The fault message stays on. The user cannot remove the "Failure" message from the Normal mode screen.	1	ERR 101 (Error)	Current Output Drift
			3	ERR 102 (Error)	Temperature Out of Range
			1	ERR 103 (Error)	Converter EEPROM
			1	ERR 103 (Error)	Converter RAM
			1	ERR 103 (Error)	Converter ROM
			1	ERR 104 (Error)	Converter Voltage
			2	ERR 200 (Error)	Reference Lost
			2	ERR 202 (Error)	Peak Lost (Level Lost)
			2	ERR 204 (Error)	Overfill
			3	ERR 205 (Error)	Internal Communication
			1	ERR 206 (Error)	No Probe detected
			1	ERR 207 (Error)	Sensor EEPROM
			1	ERR 207 (Error)	Sensor RAM
			1	ERR 207 (Error)	Sensor ROM
			1	ERR 208 (Error)	Oscillator Frequency
3	ERR 209 (Error)	Sensor Not compatible			
2, 4	ERR 210 (Error)	Empty			
	Function check	The device operates correctly, but the measured value is incorrect. This fault message is only temporary. This symbol is shown when the user configures the device with the DTM or a HART® Communicator.	-	-	-
	Out of specification	It is possible that the measured value is unstable if the operating conditions do not agree with the device specification.	4	(Warning)	Peak Lost
			4	(Warning)	Overfill
			4	(Warning)	Empty
			4	(Warning)	Temperature out of range

If an "Out of specification" status symbol is shown, refer to menu item 2.2.2 DIAGNOSTIC (Configuration mode / Supervisor menu) for more data.

For data on errors, error records and error codes, refer to *Error handling* on page 92.

6.5.2 Error handling

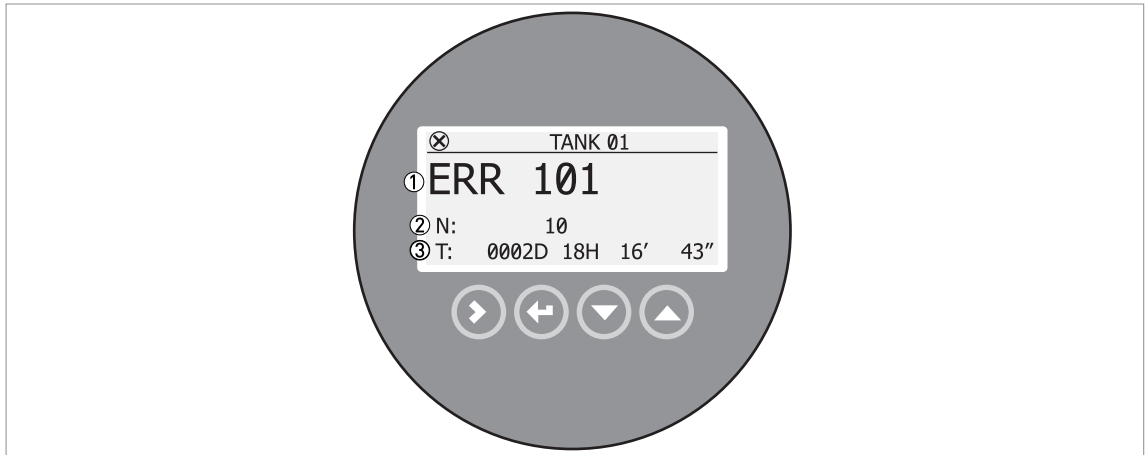

Figure 6-10: Error record data

- ① Error code for the error
- ② Number of times the error occurred
- ③ Time since the last error record (2 days, 18 hours, 16 minutes and 43 seconds shown in this example)

**How to find an error record**

- Push [➤] to enter configuration mode from normal mode.
- Push [➤], 2 × [▲] and [➤] to go to menu item 1.3.1 ERROR RECORD.
- Push 2 × [➤] to look at the error list. Push [▲] or [▼] for the selection of an error.
- ➡ The error record gives the number of times the error occurred and the time since the last error message.

**INFORMATION!**

The time since the error occurred is measured in Days (D), Hours (H), Minutes (') and Seconds ("). It only includes the time when the device is energized. The error is saved in the memory of the device when it is de-energized. The counter continues when the device is energized again.

Description of errors and corrective actions

Error code	Error Message	Status marker shown	Cause	Corrective action
------------	---------------	---------------------	-------	-------------------

Back end errors

ERR 100	Device reset	1	The device detected an internal error. (watchdog timer issue)	Record the data that is in menu item 2.2.2 DIAGNOSTIC (Configuration mode / Supervisor menu). Speak to the supplier.
ERR 101	Current output drift	1	The current output is not calibrated.	Speak to the supplier to get the calibration procedure.
		1	Hardware error.	Replace the device.
ERR 102	Temperature out of range	3	The ambient temperature is outside the given range. This can cause loss or corruption of data.	Measure the ambient temperature. De-energize the device until the ambient temperature is back in the given range. If the temperature does not stay in the correct range, make sure that there is insulation around the signal converter. If this error occurs 2 times, replace the device.
ERR 103	Converter memory failure	1	The device's hardware is defective.	Replace the signal converter. For more data, refer to <i>How to turn or remove the signal converter</i> on page 43.
ERR 104	Converter voltage failure	1	The device's hardware is defective.	Replace the signal converter. For more data, refer to <i>How to turn or remove the signal converter</i> on page 43.

Sensor errors

ERR 200	Reference pulse lost	2	Reference amplitude is less than reference threshold. This fault could occur because the device hardware is defective.	Speak to your supplier to make sure that the electronics are still functioning correctly. Make sure that your installation has ESD protection. For more data, refer to <i>Nozzles on conical silos</i> on page 28.
ERR 201	Sensor voltage failure	1	The device's hardware is defective.	Do a check of the power supply at the device terminals. Make sure that voltage values are in the specified limits in menu item 2.2.2 DIAGNOSTIC (Configuration mode / Supervisor menu). If the voltage is correct, replace the signal converter. For more data on how to replace the signal converter, refer to <i>How to turn or remove the signal converter</i> on page 43.

Error code	Error Message	Status marker shown	Cause	Corrective action
ERR 202	Level lost error	2, 4	The device cannot find the product surface. The measurement stops at the last measured value.	<p>Measure the level of the contents in the tank using another method of measurement. If the tank is empty (the level is below the end of the probe), then fill the tank until product level is in the measurement range. If the tank is full (the level is in the blocking distance), then remove the contents from the tank until the level is back in the measuring range. If the product was lost and the tank is neither full nor empty, wait for the device to find the level again.</p> <p>If the device has to measure a product with $\epsilon_r \geq 1.6$, refer to MEAS. AMP. (Measured Pulse Amplitude, menu item 2.5.6) and then adjust MEAS. THRESH. (measurement threshold, menu item 2.5.7). If the product has a low dielectric constant ($\epsilon_r < 1.6$) and the device is in TBF mode, refer to PROBE END AMP (probe end pulse amplitude, menu item 2.5.8) and then adjust PROBE END TH. (probe end threshold, menu item 2.5.9). For more data, refer to <i>Thresholds and parasitic signals</i> on page 86.</p> <p>Make sure that the signal converter is correctly attached to the probe. For more data, refer to <i>How to turn or remove the signal converter</i> on page 43.</p>
		2, 4	The device cannot find the level return signal and the probe end return signal.	
ERR 204	Overfill error	2, 4	The level is in the blocking distance. There is a risk that the product will overflow and/or cover the device.	Remove some of the product until the level is below the blocking distance.
ERR 205	Internal Communication	3	The device's hardware or software is defective. The converter cannot transmit signals to or receive signals from the probe electronics.	De-energize the device. Make sure that the signal cable engages in the terminal and the screw connection is tight. Energize the device. If the problem continues, replace the signal converter. For more data, refer to <i>How to turn or remove the signal converter</i> on page 43.
ERR 206	No sensor detected	2	The device's hardware is defective.	Replace the signal converter. For more data, refer to <i>How to turn or remove the signal converter</i> on page 43.
ERR 207	Sensor memory failure	1	The device's hardware is defective.	Replace the signal converter. For more data, refer to <i>How to turn or remove the signal converter</i> on page 43.

Error code	Error Message	Status marker shown	Cause	Corrective action
ERR 208	Oscillator Frequency	1	The device's hardware is defective.	Replace the signal converter. For more data, refer to <i>How to turn or remove the signal converter</i> on page 43.
ERR 209	Sensor not compatible	1	The software version of the sensor is not compatible with the software version of the signal converter.	Go to menu 1.1.0 IDENT. in Configuration mode. Record the version numbers of the device software given in menu items 1.1.2, 1.1.3 and 1.1.4. Give this data to the supplier.
		1	Defective wiring.	
ERR 210	Empty	2, 4	The level is in the bottom dead zone. There is a risk that the tank is empty.	Add some of the product until the level is above the bottom dead zone.



INFORMATION!

In 4.0.0 MASTER menu, the type of error shown for error codes 102, 201 and 203 can be changed from "Error" to "Warning" (the NE 107 status signal changes from "Failure" to "Out of specification"). For more data, speak to the supplier.

7.1 Periodic maintenance

No maintenance is necessary.



WARNING!

Do not use bleach to clean the signal converter.

7.2 Keep the device clean



Obey these instructions:

- Keep the thread of the terminal compartment cover clean.
- If dirt collects on the device, clean it.

7.3 How to replace device components

7.3.1 Service warranty



WARNING!

Only approved personnel can do an inspection of the device and repairs. If you find a problem, send the device back to the supplier for inspection and/or repairs.



INFORMATION!

*The converter housing (compact or remote version) can be detached from the process connection assembly under process conditions. For more data, refer to *How to turn or remove the signal converter* on page 43.*

Servicing by the customer is limited by warranty to:

- The removal and installation of the device.
- **Compact version:** The removal and installation of the signal converter (with the weather protection, if this option is attached). For more data, refer to *How to turn or remove the signal converter* on page 43.
- **Remote (field) version:** The removal and installation of the remote converter and/or the probe housing. For more data, refer to *How to turn or remove the signal converter* on page 43.
- **Replacement of signal converters of other TDR devices:** The removal of a VF03, VF04 or VF7 signal converter and installation of the VF2 signal converter. For the procedure, refer to *Replacement of the VF04 signal converter* on page 96.

For more data on how to prepare the device before you send it back, refer to *Returning the device to the manufacturer* on page 109.

7.3.2 Replacement of the VF04 signal converter



INFORMATION!

Complete the 5 procedures that follow in numerical sequence.

To get the passwords for the VF04 and VF2 Service menus, speak to the supplier.

Equipment needed:

- 5 mm Allen wrench (not supplied)
- 8 mm open-end wrench (not supplied)
- Wrench for housing cover

- Option: Bar magnet
- VF04 TDR level meter
- VF2 signal converter (without process connection and probe)
- The applicable adaptor for the process connection. You can send an order for this part only or for the VF2 signal converter with the adaptor attached. For the order code, refer to *Order code* on page 146.
- Handbooks for all devices
- Option: Workstation (not supplied) with PACTware and DTM installed
- Option: PACTware supplement (if a workstation is used to set up and monitor the device)
- Option: HART® handheld terminal (not supplied)

**CAUTION!**

Make sure that you also record device configuration data. This data includes basic configuration (tank height, blocking distance etc.), output, application, display, strapping table, mechanical calibration ratio and converter offset data. You can find this data in Configuration mode. The mechanical calibration speed and offset values are in the SERVICE menu. If you do not have the password for the SERVICE menu, speak to the supplier.

**INFORMATION!**

You can see the device settings on the display screen (if your device has this option), at a workstation with PC STAR software or with a HART® handheld terminal. For more data about the software, refer to the VF04 handbook.

**Procedure 1: Record the parameters**

- ① Record the probe type and probe length.
- ② If you use the Hall effect sensors, it is unnecessary to remove the front cover of the signal converter. Use the supplied magnet to "push" the buttons. If you do not have the magnet, remove the cover with the supplied wrench.
 - ➔ For more data about the display screen, keypad buttons and Hall effect sensors, refer to the applicable handbook.
- ③ Energize the device.
 - ➔ The device is in operation and in Operating Mode.
- ④ Push the [➤] button to enter Configuration Mode.
 - ➔ If the device has password protection, The display screen shows the text "CodE1".
- ⑤ If the device has password protection, enter the password (default setting: [▲], [▲], [▲], [←], [←], [←], [➤], [➤] and [➤]).
- ⑥ Record parameters in these menu items: 1.1.1 TANK HEIGHT, 1.1.2 HOLD DIST., 1.4.9 PROBE TYPE, 1.5.3 DETE. DELAY, 1.3.1 FUNCTION.I.1, 1.3.3 SCAL.I.1 MIN, 1.3.4 SCAL.I.1 MAX and 1.7.2 INPUT.TAB. (strapping table values).
- ⑦ Push 4 × [←] to go back to the Operating Mode.
- ⑧ Push the [←] button to enter the Configuration Mode (Service).
 - ➔ If the device has password protection, The display screen shows the text "CodE2".
- ⑨ Give the password for the SERVICE menu. If you do not have the password, speak to the supplier.
- ⑩ Record parameters in these menu items: 2.5 M.CAL. SPEED. and 2.7 OFFSET.
- ⑪ Push 2 × [←] to go back to the Operating Mode.
- ⑫ De-energize the device.
- ⑬ Remove the electrical cables.
- ⑭ Attach the signal converter cover.

Procedure 2A: How to remove the VF04 signal converter (non-Ex devices)

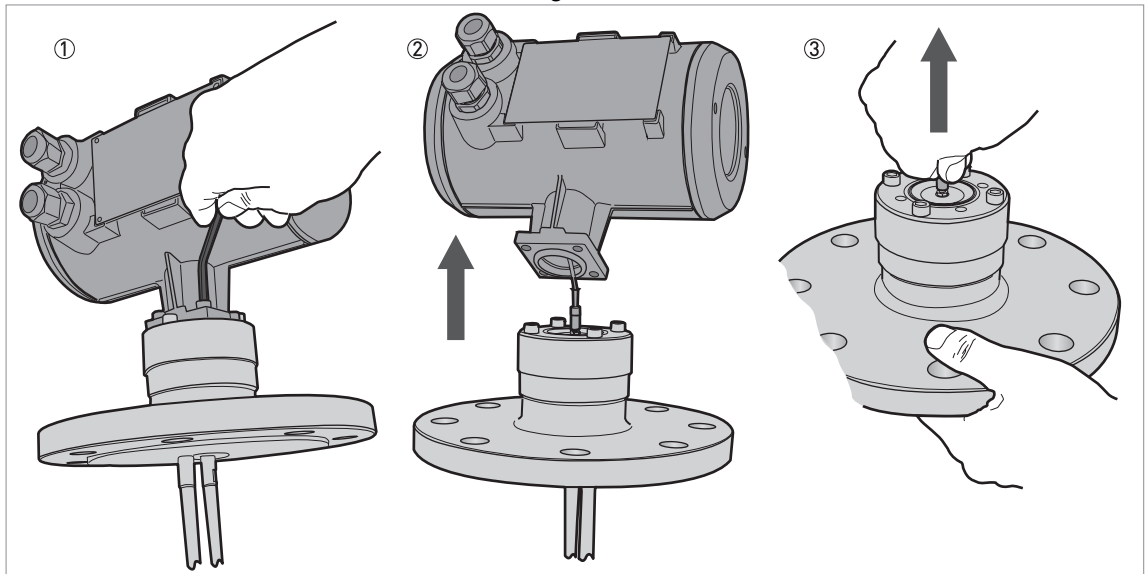

Figure 7-1: Procedure 2A: How to remove the VF04 signal converter (non-Ex devices)



WARNING!

De-energize the device and disconnect the electrical cables before you remove the signal converter.



- ① Remove the 4 socket head screws at the bottom of the signal converter with a 5 mm Allen wrench.
- ② Remove the signal converter from the process connection. Make sure that you do not damage the 50 ohm wire.
- ③ Disconnect the 50 ohm wire connector from the process connection.

Procedure 2B: How to remove the VF04 signal converter (Ex-approved devices)

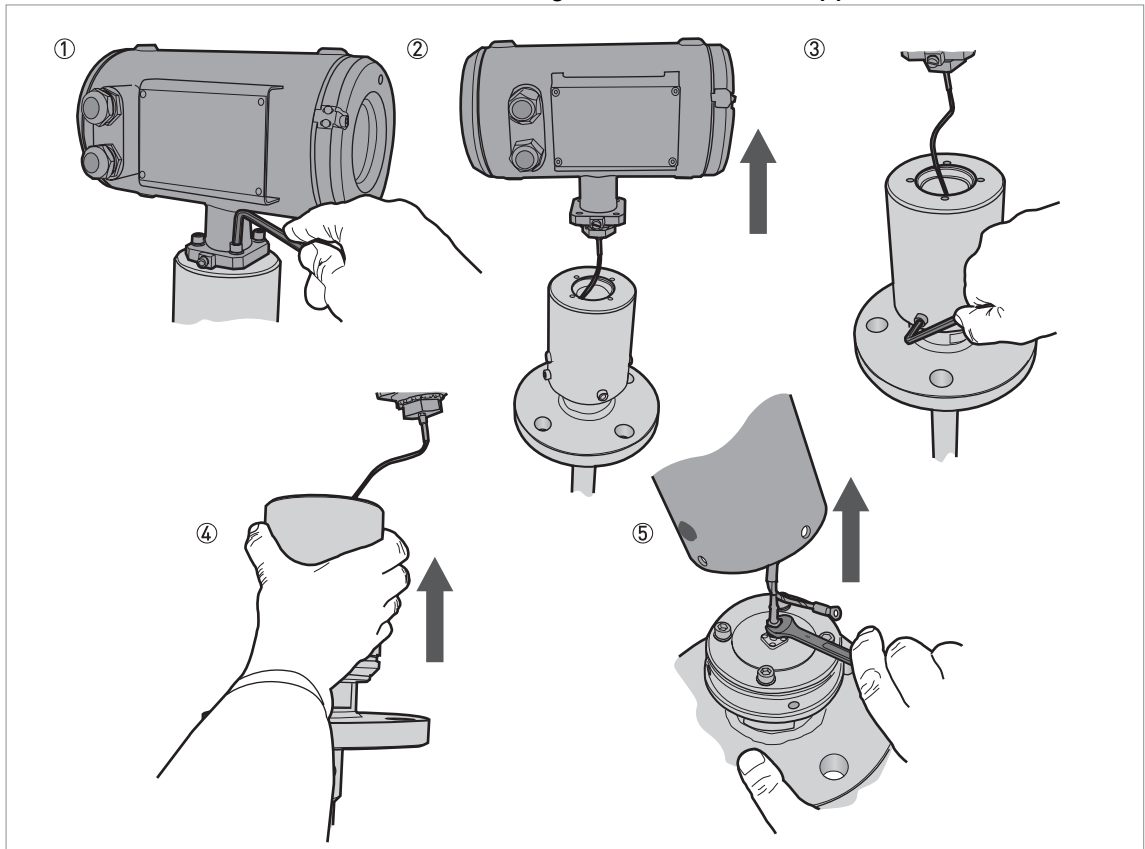

Figure 7-2: Procedure 2B: How to remove the VF04 signal converter (Ex-approved devices)



WARNING!

De-energize the device and disconnect the electrical cables before you remove the signal converter.



- ① Remove the 4 socket head screws at the bottom of the signal converter with a 5 mm Allen wrench.
- ② Remove the signal converter from the isolating chamber. Make sure that you do not damage the 50 ohm wire.
- ③ Remove the 4 socket head screws at the bottom of the isolating chamber with a 5 mm Allen wrench.
- ④ Remove the isolating chamber from the process connection. Make sure that you do not damage the isolating chamber seal or the 50 ohm wire.
- ⑤ Disconnect the 50 ohm wire connector from the process connection with an 8 mm open-end wrench.

Procedure 3A: How to attach the VF2 signal converter (non-Ex devices)

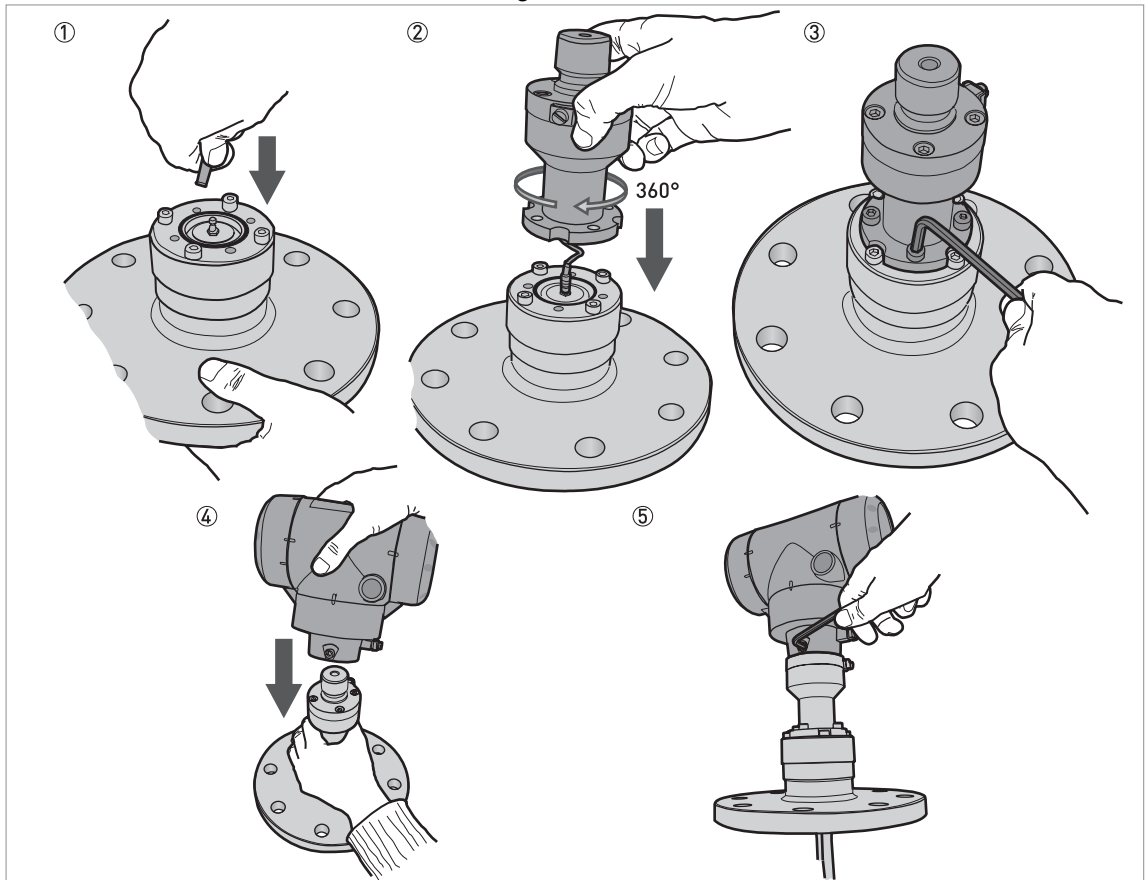

Figure 7-3: Procedure 3A: How to attach the VF2 signal converter (non-Ex devices)



- ① Connect the 50 ohm wire connector to the process connection with an 8 mm open-end wrench.
- ② Before you attach the adaptor, turn the adaptor 360° to prevent damage to the 50 ohm wire.
- ③ Attach the adaptor to the process connection. Tighten the 4 socket head screws with a 5 mm Allen wrench.
- ④ Put the VF2 signal converter on the adaptor. Make sure that the adaptor fully engages in the mating part (signal converter).
- ⑤ Tighten the socket set screw at the bottom of the signal converter with a 5 mm Allen wrench.

Procedure 3B: How to attach the VF2 signal converter (Ex-approved devices)

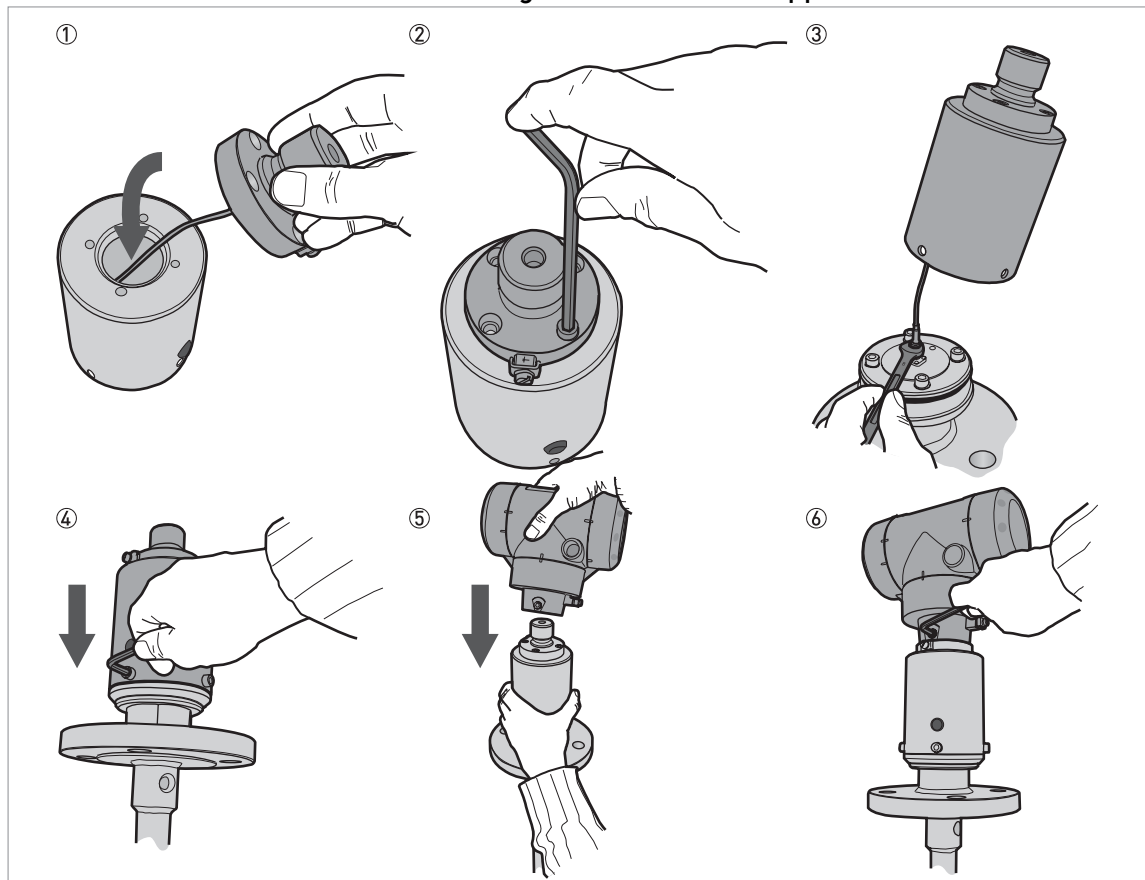

Figure 7-4: Procedure 3B: How to attach the VF2 signal converter (Ex-approved devices)



WARNING!

Make sure that mating surfaces are clean. The isolating chamber must be air-tight.



- ① Attach the adaptor to the top of the isolating chamber.
- ② Tighten the 4 socket head screws with a 5 mm Allen wrench.
- ③ Connect the 50 ohm wire connector to the process connection with an 8 mm open-end wrench.
- ④ Attach the isolating chamber to the process connection. The holes in the isolating chamber must align with the holes in the process connection. Make sure that you do not damage the 50 ohm wire. Attach the 4 socket head screws at the bottom of the isolating chamber with a 5 mm Allen wrench.
- ⑤ Put the VF2 signal converter on the adaptor. Make sure that the adaptor fully engages in the mating part (signal converter).
- ⑥ Tighten the socket set screw at the bottom of the signal converter with a 5 mm Allen wrench.



INFORMATION!

The procedure that follows calibrates the new device. You must have 2 reference points (levels) in the tank given by a different measurement solution (an approved level meter or indicator). These points are identified as reference point 1 (R1) and reference point 2 (R2). R1 is the point where the tank is approximately 20% full. R2 is the point where the tank is approximately 80% full.



Procedure 4: How to calculate the mechanical calibration speed and the measurement offset (VF2)

- ① Install the device on the tank.
- ② Energize the device. Make sure that the display screen shows "Distance" measurements.
 - The device is in operation and in normal mode. It will not measure correctly until it is correctly calibrated.
- ③ Change the level to R1.
- ④ Record D1, the distance shown on the display screen of the device.
- ⑤ Change the level to R2.
- ⑥ Record D2, the distance shown on the display screen of the device.
- ⑦ Calculate the ratio, A. $A = (D2 - D1) / (R2 - R1)$.
- ⑧ Calculate the new mechanical calibration speed. New mechanical calibration speed (VF2) = Old calibration factor (VF04) \times A
- ⑨ Calculate the offset, B. $B = D1 - (A \times R1)$.
- ⑩ Calculate the new measurement offset. New measurement offset (VF2) = Old converter offset (VF04) \times A



Procedure 5: How to set the mechanical calibration speed and the measurement offset (VF2)

- ① Energize the device.
 - The device is in operation and in normal mode. It will not measure correctly until new values are set in menu items 3.1.4 OFFSET MEAS. (Measurement Offset) and 3.1.6 M.CAL. SPEED (Mechanical Calibration Speed).
- ② Push [➤], 2 \times [▲] and [➤] to go to the SERVICE menu (3.0.0).
- ③ Give the password for the SERVICE menu. If you do not have the password, speak to the supplier.
- ④ Push [➤] and 3 \times [▲] to go to menu item 3.1.4 OFFSET MEAS.
- ⑤ Push [➤] to change the value. Enter the new measurement offset value that you calculated in procedure 4.
- ⑥ Push [←], 2 \times [▲] to go to menu item 3.1.6 M.CAL. SPEED.
- ⑦ Push [➤] to change the value. Enter the new mechanical calibration speed value that you calculated in procedure 4.
- ⑧ Push 4 \times [←]. Push [▲] or [▼] for the selection of the save option (STORE NO or STORE YES). Set to "STORE YES" to save and use the data.
- ⑨ Push [←] to confirm.
- The device is in normal mode. The device uses the new values.



CAUTION!

You recorded device configuration data of the VF04 level meter before you attached the new signal converter. Make sure that you enter this data in the supervisor menu of the VF2.



Procedure 6: Device configuration (VF2)

- For the Quick Setup procedure, refer to *Quick Setup* on page 79. For more data about device configuration, refer to *Operation* on page 66.

7.3.3 Replacement of the VF03 signal converter



INFORMATION!

Complete the 5 procedures that follow in numerical sequence.

To get the passwords for the VF03 and VF2 Service menus, speak to the supplier.

Equipment needed:

- 4 mm Allen wrench (not supplied)
- VF03 TDR level meter
- VF2 signal converter (without process connection and probe)
- The applicable adaptor for the process connection. You can send an order for this part only or for the VF2 signal converter with the adaptor attached. For the order code, refer to *Order code* on page 146.
- Handbooks for all devices
- Option: Workstation (not supplied) with PACTware and DTM installed
- Option: PACTware supplement (if a workstation is used to set up and monitor the device)
- Option: HART® handheld terminal (not supplied)



CAUTION!

Make sure that you also record device configuration data. This data includes basic configuration (tank height, blocking distance etc.), output, application, display, strapping table, mechanical calibration speed and offset data. You can find this data in Configuration mode. The mechanical calibration speed and offset values are in the SERVICE menu. If you do not have the password for the SERVICE menu, speak to the supplier.



INFORMATION!

You can see the device settings on a workstation with PCSTAR 2 software or with a HART® handheld terminal. For more data about the software, refer to the VF03 handbook.



Procedure 1: Record the parameters (VF03 TDR level meters)

- ① Record the probe type and probe length.
- ② Energize the device.
 - ➡ The device is in operation and in Operating Mode.
- ③ Use PCSTAR 2 software or a HART® Handheld Terminal to record parameters in these menu items: TANK HEIGHT, DEAD ZONE, PROBE TYPE, DETECTION DELAY, FUNCTION.I.1, SCALE I (MIN/4 mA), SCALE I (MAX/20 mA), INPUT TABLE (strapping table values), M.CAL. SPEED. and OFFSET.
- ④ De-energize the device.
- ⑤ Remove the electrical cables.

Procedure 2: How to remove the VF03 signal converter

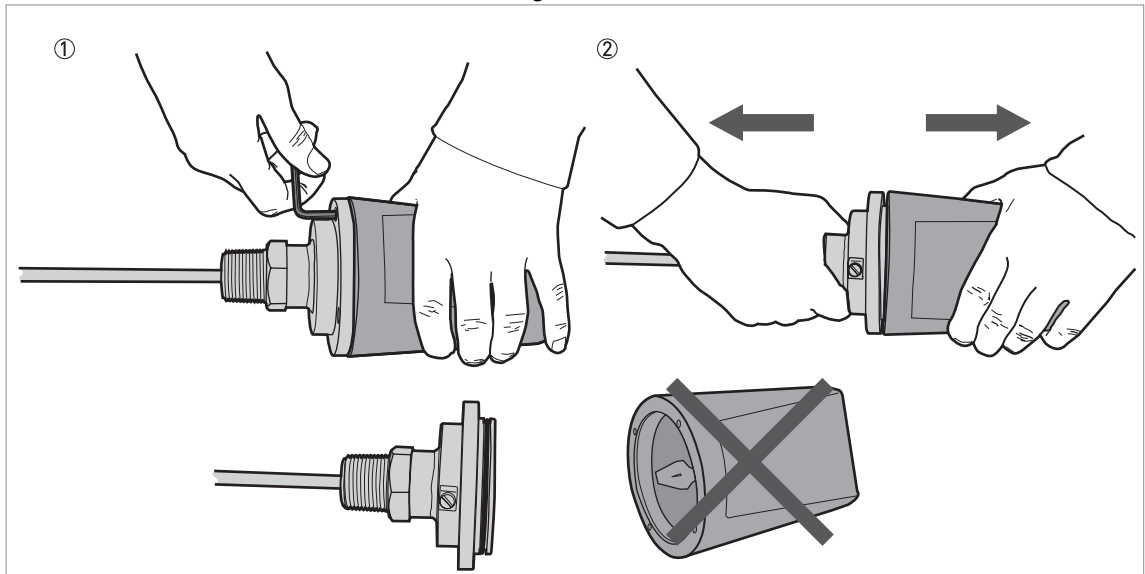

Figure 7-5: Procedure 2: How to remove the VF03 signal converter



WARNING!

De-energize the device and disconnect the electrical cables before you remove the signal converter.



- ① Remove the 4 socket head screws at the bottom of the signal converter with a 4 mm Allen wrench.
- ② Remove the signal converter from the process connection



WARNING!

Be careful with the pin connector below the adaptor. If the pin connector is damaged, the device will not measure level correctly.



- ① Attach the adaptor to the top of process connection.
- ② Tighten the 4 socket head screws with a 4 mm Allen wrench.
- ③ Put the VF2 signal converter on the adaptor. Make sure that the adaptor fully engages in the mating part (signal converter).
- ④ Tighten the socket set screw at the bottom of the signal converter with a 5 mm Allen wrench.



INFORMATION!

The procedure that follows calibrates the new device. You must have 2 reference points (levels) in the tank given by a different measurement solution (an approved level meter or indicator). These points are identified as reference point 1 (R1) and reference point 2 (R2). R1 is the point where the tank is approximately 20% full. R2 is the point where the tank is approximately 80% full.



Procedure 4: How to calculate the mechanical calibration speed and the measurement offset (VF2)

- ① Install the device on the tank.
- ② Energize the device. Make sure that the display screen shows "Distance" measurements.
 - The device is in operation and in normal mode. It will not measure correctly until it is correctly calibrated.
- ③ Change the level to R1.
- ④ Record D1, the distance shown on the display screen of the device.
- ⑤ Change the level to R2.
- ⑥ Record D2, the distance shown on the display screen of the device.
- ⑦ Calculate the ratio, A. $A = (D2 - D1) / (R2 - R1)$.
- ⑧ Calculate the new mechanical calibration speed. New mechanical calibration speed (VF2) = Old calibration factor (VF03) \times A
- ⑨ Calculate the offset, B. $B = D1 - (A \times R1)$.
- ⑩ Calculate the new measurement offset. New measurement offset (VF2) = Old converter offset (VF03) \times A



Procedure 5: How to set the mechanical calibration speed and the measurement offset (VF2)

- ① Energize the device.
 - The device is in operation and in normal mode. It will not measure correctly until new values are set in menu items 3.1.4 OFFSET MEAS. (Measurement Offset) and 3.1.6 M.CAL. SPEED (Mechanical Calibration Speed).
- ② Push [➤], 2 \times [▲] and [➤] to go to the SERVICE menu (3.0.0).
- ③ Give the password for the SERVICE menu. If you do not have the password, speak to the supplier.
- ④ Push [➤] and 3 \times [▲] to go to menu item 3.1.4 OFFSET MEAS.
- ⑤ Push [➤] to change the value. Enter the new measurement offset value that you calculated in procedure 4.
- ⑥ Push [←], 2 \times [▲] to go to menu item 3.1.6 M.CAL. SPEED.
- ⑦ Push [➤] to change the value. Enter the new mechanical calibration speed value that you calculated in procedure 4.
- ⑧ Push 4 \times [←]. Push [▲] or [▼] for the selection of the save option (STORE NO or STORE YES). Set to "STORE YES" to save and use the data.
- ⑨ Push [←] to confirm.
- The device is in normal mode. The device uses the new values.



CAUTION!

You recorded device configuration data of the VF03 level meter before you attached the new signal converter. Make sure that you enter this data in the supervisor menu of the VF2.



Procedure 6: Device configuration (VF2)

- For the Quick Setup procedure, refer to *Quick Setup* on page 79. For more data about device configuration, refer to *Operation* on page 66.

7.3.4 Replacement of the VF7 signal converter



INFORMATION!

Complete the 5 procedures that follow in numerical sequence. These procedures are applicable only to devices that were made before August 2009.

To get the passwords for the VF7 and VF2 Service menus, speak to the supplier.

Equipment needed:

- 5 mm Allen wrench (not supplied)
- VF7 TDR level meter
- VF2 signal converter (without process connection and probe)
- The applicable adaptor for the process connection. You can send an order for this part only or for the VF2 signal converter with the adaptor attached. For the order code, refer to *Order code* on page 146.
- Handbooks for all devices
- Option: Workstation (not supplied) with PACTware and DTM installed
- Option: PACTware supplement (if a workstation is used to set up and monitor the device)
- Option: HART® handheld terminal (not supplied)



CAUTION!

Make sure that you also record device configuration data. This data includes basic configuration (tank height, blocking distance etc.), output, application, display and strapping table, converter offset and mechanical calibration ratio data. You can find this data in the Supervisor and Service menus. If you do not have the password for the SERVICE menu, speak to the supplier.



INFORMATION!

You can see the device settings on the display screen (if your device has this option), at a workstation with PACTware software or with a HART® Handheld Terminal. For more data about the software, refer to the PACTware supplement or PACTware embedded Help for each device.



Procedure 1: Record the parameters (VF7 TDR level meters)

- ① Record the probe type and probe length.
- ② Energize the device.
 - ➡ The device is in operation and in Normal Mode.
- ③ Push [➤], [▲] and [➤] to enter Configuration Mode [2.0.0 SUPERVISOR].
- ④ Enter the password. Push [➤], [←], [▼], [▲], [➤] and [←].
- ⑤ Record parameters in these menu items: A.1.4 Conversion (strapping table values), B.2.7 Probe Type, C.1.9 Blocking Distance, C.1.1.0 Tank Height, Detection Delay, C.3.1 Output Function (Output 1), C.3.2 4 mA Setting (Output1) and C.3.3 20 mA Setting (Output 1).
- ⑥ Push 4 × [←] to go back to the Operating Mode.
- ⑦ Push [➤], 3 × [▲] and [➤] to enter the Service menu.
- ⑧ Give the password for the SERVICE menu. If you do not have the password, speak to the supplier.
- ⑨ Record parameters in these menu items: D2.1.0 Converter Offset and D.2.3.0 Mechanical Calibration Ratio.
- ⑩ Push 2 × [←] to go back to the Operating Mode.
- ⑪ De-energize the device.
- ⑫ Remove the electrical cables.
- ⑬ Attach the signal converter cover.

Procedure 2: How to remove the VF7 signal converter

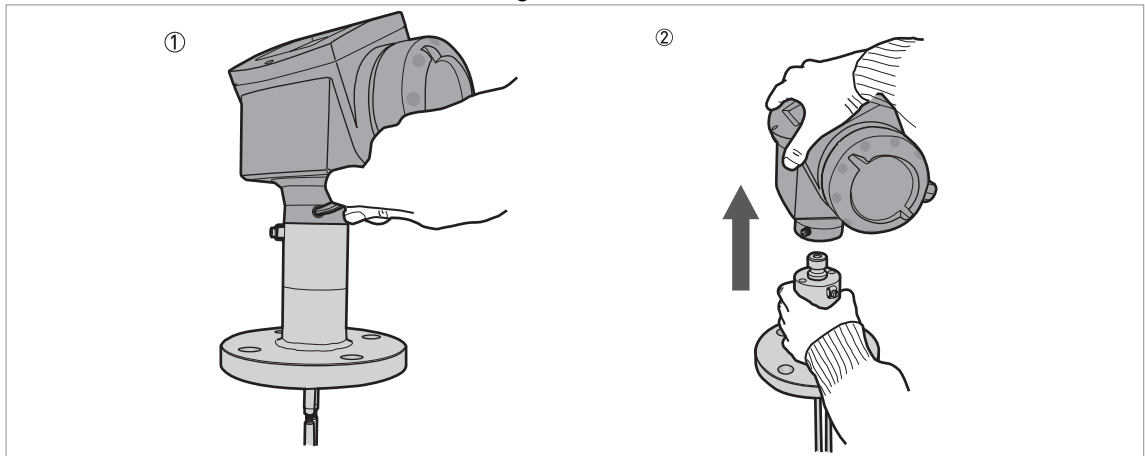

Figure 7-6: Procedure 2: How to remove the VF7 signal converter



WARNING!

De-energize the device and disconnect the electrical cables before you remove the signal converter.



- ① Remove the 4 socket head screws at the bottom of the signal converter with a 5 mm Allen wrench. Keep the screws for the subsequent procedure.
- ② Remove the signal converter from the process connection. Make sure that the gasket stays on the flange connection.

Procedure 3: How to attach the VF2 signal converter

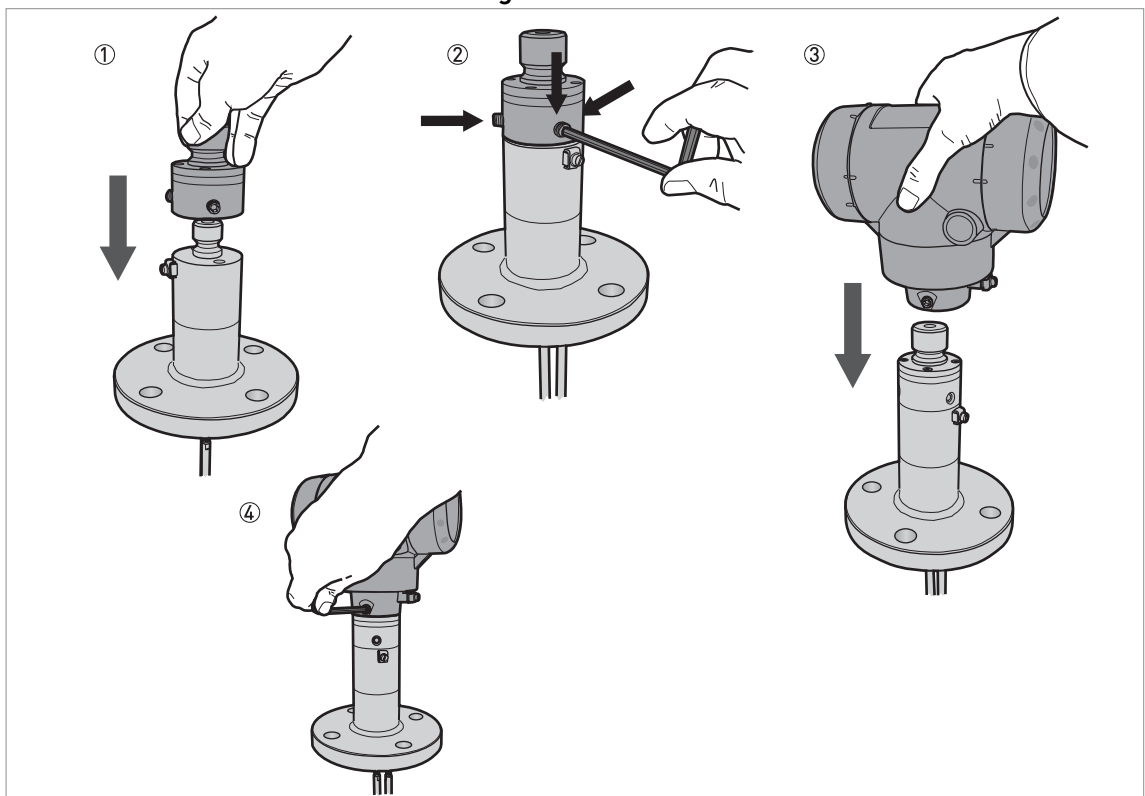

Figure 7-7: Procedure 3: How to attach the VF2 signal converter



- ① Put the adaptor on the process connection. Make sure that the adaptor fully engages in the mating part.
- ② Attach and tighten the socket head screw with a 5 mm Allen wrench.
- ③ Put the VF2 signal converter on the adaptor. Make sure that the signal converter fully engages in the mating part (adaptor).
- ④ Tighten the socket set screw at the bottom of the signal converter with a 5 mm Allen wrench.

**INFORMATION!**

The adaptor is available as a spare part. Send an order for this part only or for the VF2 signal converter with the adaptor attached. For the order code, refer to Order code on page 146.

**INFORMATION!**

The procedure that follows calibrates the new device. You must have 2 reference points (levels) in the tank given by a different measurement solution (an approved level meter or indicator). These points are identified as reference point 1 (R1) and reference point 2 (R2). R1 is the point where the tank is approximately 20% full. R2 is the point where the tank is approximately 80% full.

**Procedure 4: How to calculate the mechanical calibration speed and the measurement offset (VF2)**

- Install the device on the tank.
- Energize the device. Make sure that the display screen shows "Distance" measurements.
- ➔ The device is in operation and in normal mode. It will not measure correctly until it is correctly calibrated.
- Change the level to R1.
- Record D1, the distance shown on the display screen of the device.
- Change the level to R2.
- Record D2, the distance shown on the display screen of the device.
- Calculate the ratio, A. $A = (D2 - D1) / (R2 - R1)$.
- Calculate the new mechanical calibration speed. New mechanical calibration speed (VF2) = Old calibration factor (VF7) × A
- Calculate the offset, B. $B = D1 - (A \times R1)$.
- Calculate the new measurement offset. New measurement offset (VF2) = Old converter offset (VF7) × A

**Procedure 5: How to set the mechanical calibration speed and the measurement offset (VF2)**

- ① Energize the device.
- ➔ The device is in operation and in normal mode. It will not measure correctly until new values are set in menu items 3.1.4 OFFSET MEAS. (Measurement Offset) and 3.1.6 M.CAL. SPEED (Mechanical Calibration Speed).
- ② Push [➤], 2 × [▲] and [➤] to go to the SERVICE menu (3.0.0).
- ③ Give the password for the SERVICE menu. If you do not have the password, speak to the supplier.
- ④ Push [➤] and 3 × [▲] to go to menu item 3.1.4 OFFSET MEAS.
- ⑤ Push [➤] to change the value. Enter the new measurement offset value that you calculated in procedure 4.
- ⑥ Push [←], 2 × [▲] to go to menu item 3.1.6 M.CAL. SPEED.
- ⑦ Push [➤] to change the value. Enter the new mechanical calibration speed value that you calculated in procedure 4.
- ⑧ Push 4 × [←]. Push [▲] or [▼] for the selection of the save option (STORE NO or STORE YES). Set to "STORE YES" to save and use the data.

- ⑨ Push [←] to confirm.
- ➡ The device is in normal mode. The device uses the new values.

**CAUTION!**

You recorded device configuration data of the VF7 level meter before you attached the new signal converter. Make sure that you enter this data in the supervisor menu of the VF2.

**Procedure 6: Device configuration (VF2)**

- For the Quick Setup procedure, refer to *Quick Setup* on page 79. For more data about device configuration, refer to *Operation* on page 66.

7.4 Availability of services

The manufacturer offers a range of services to support the customer after expiration of the warranty. These include repair, maintenance, technical support and training.

**INFORMATION!**

For more precise information, please contact your local sales office.

7.5 Returning the device to the manufacturer

7.5.1 General information

This device has been carefully manufactured and tested. If installed and operated in accordance with these operating instructions, it will rarely present any problems.

**CAUTION!**

Should you nevertheless need to return a device for inspection or repair, please pay strict attention to the following points:

- *Due to statutory regulations on environmental protection and safeguarding the health and safety of our personnel, manufacturer may only handle, test and repair returned devices that have been in contact with products without risk to personnel and environment.*
- *This means that the manufacturer can only service this device if it is accompanied by the following certificate (see next section) confirming that the device is safe to handle.*

**CAUTION!**

If the device has been operated with toxic, caustic, flammable or water-endangering products, you are kindly requested:

- *to check and ensure, if necessary by rinsing or neutralising, that all cavities are free from such dangerous substances,*
- *to enclose a certificate with the device confirming that is safe to handle and stating the product used.*

7.5.2 Form (for copying) to accompany a returned device

Company:		Address:	
Department:		Name:	
Tel. no.:		Fax no.:	
Manufacturer's order no. or serial no.:			
The device has been operated with the following medium:			
This medium is:	water-hazardous		
	toxic		
	caustic		
	flammable		
	We checked that all cavities in the device are free from such substances.		
	We have flushed out and neutralized all cavities in the device.		
We hereby confirm that there is no risk to persons or the environment through any residual media contained in the device when it is returned.			
Date:		Signature:	
Stamp:			

7.6 Disposal

**CAUTION!**

Disposal must be carried out in accordance with legislation applicable in your country.

8.1 Measuring principle

This Guided Radar (TDR) level meter has been developed from a proven technology called Time Domain Reflectometry (TDR).

The device transmits low-intensity electromagnetic pulses of approximately one nanosecond width along a rigid or flexible conductor. These pulses move at the speed of light. When the pulses reach the surface of the product to be measured, the pulses are reflected back to the signal converter.

The device measures the time from when the pulse is transmitted to when it is received: half of this time is equivalent to the distance from the reference point of the device to the surface of the product. The time value is converted into an output current of 4...20 mA.

Dust, foam, vapour, agitated surfaces, boiling surfaces, changes in pressure, changes in temperature, changes in dielectric constant and changes in density do not have an effect on device performance.

The illustration that follows shows a snapshot of what a user would see on an oscilloscope, if the level of one product is measured.

TDR measurement of level

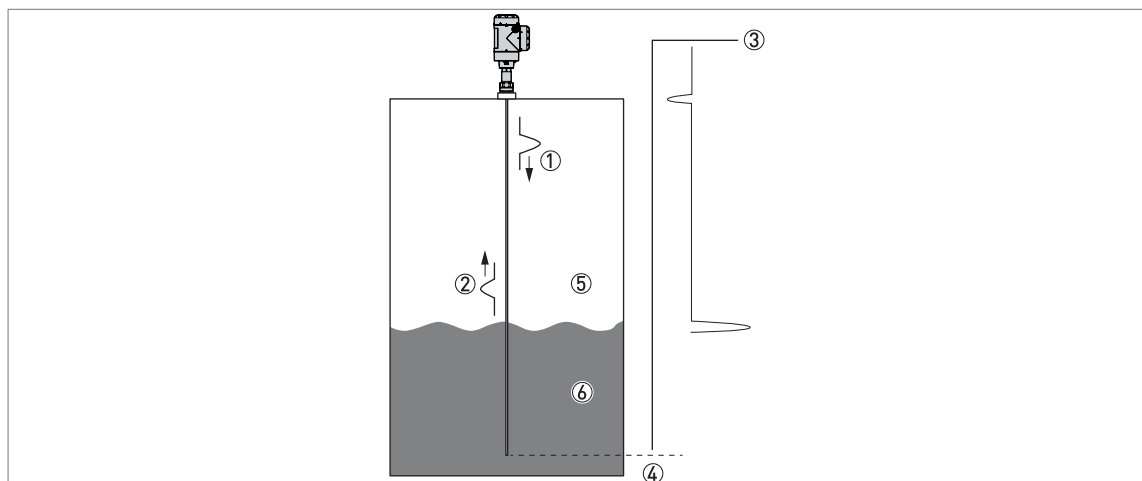

Figure 8-1: TDR measurement of level

- ① Transmitted pulses
- ② Reflected pulse
- ③ Pulse amplitude
- ④ Time of flight
- ⑤ Air, $\epsilon_r = 1$
- ⑥ $\epsilon_r \geq 1.4$ in direct mode or $\epsilon_r \geq 1.1$ in TBF mode

8.2 Technical data



INFORMATION!

- The following data is provided for general applications. If you require data that is more relevant to your specific application, please contact us or your local sales office.
- Additional information (certificates, special tools, software,...) and complete product documentation can be downloaded free of charge from the website.

Converter

Measuring system

Application	Level and volume measurement of liquids, pastes, powders and granulates
Measuring principle	TDR (time domain reflectometry)
Construction	Compact version: Measuring probe attached directly to a signal converter Remote version: Measuring probe installed on a tank and connected by a signal cable (max. length 100 m / 328 ft) to a signal converter

Operating conditions

Ambient temperature	-40...+80°C / -40...+176°F Integrated LCD display: -20...+60°C / -5...+140°F; if the ambient temperature is not in these limits, the display switches off
Storage temperature	-50...+85°C / -60...+185°F (min. -40°C / -40°F for devices with the integrated LCD display option)
Protection category	IP 66/67 equivalent to NEMA type 4X (housing) and type 6P (probe)

Materials

Housing	Polyester-coated aluminium or stainless steel (1.4404 / 316L)
Cable entry	Plastic; nickel-plated brass, stainless steel

Electrical connections

Power supply (terminals)	Terminals output - Non-Ex / Ex i: 12...30 VDC; min./max. value for an output of 22 mA at the terminal
	Terminals output - Ex d: 16...36 VDC; min./max. value for an output of 22 mA at the terminal
Current output load	Non-Ex / Ex i: $R_L [\Omega] \leq ((U_{ext} - 12 \text{ V})/22 \text{ mA})$. For more data, refer to <i>Minimum power supply voltage</i> on page 118.
	Ex d: $R_L [\Omega] \leq ((U_{ext} - 16 \text{ V})/22 \text{ mA})$. For more data, refer to <i>Minimum power supply voltage</i> on page 118.
Cable entry	M20 × 1.5; ½ NPT
Cable gland	Standard: none
	Options: M20×1.5 (cable diameter: 6...12 mm / 0.23...0.47"); others are available on request
Signal cable - remote version	None for non-Ex devices (4-wire shielded cable of max. length 100 m / 328 ft to be supplied by the customer). Supplied with all Ex-approved devices. For more data, refer to <i>Remote device data</i> on page 50
Cable entry capacity (terminal)	0.5...2.5 mm ²

Input and output

Measured variable	Time between the emitted and received signal
Output signal	4...20 mA HART® or 3.8...20.5 mA acc. to NAMUR NE 43 ①
Resolution	±3 µA
Temperature drift (analog)	Typically 50 ppm/K
Temperature drift (digital)	Max. ±15 mm for the full temperature range
Error signal options	High: 22 mA; Low: 3.6 mA acc. to NAMUR NE 43; Hold (frozen value - not available if the output agrees with NAMUR NE 43) ②
PROFIBUS PA (pending)	
Type	2-wire loop-powered level transmitter; Time Domain Reflectometry
Function blocks	4 (level, distance, ullage conversion, level conversion)
Protocol / Communication standard	PROFIBUS PA protocol that agrees with IEC 61158-2
Physical layer types	Standard power signaling, bus powered, non I.S.
Current consumption on PROFIBUS network	14 mA
Output data	Level, distance, ullage conversion, level conversion
Input data	None
Error current FDE	Typically 0 mA (FDE =Fault Disconnection Electronic)
Address range	0...125. Default address: 126.
FOUNDATION™ fieldbus (pending)	
Type	2-wire loop-powered level transmitter; Time Domain Reflectometry
Function blocks	1 × Resource Block (RB), 4 × Analog Input Blocks (AI), 1 × Transducer Block (TB), 1 × Proportional Integral Derivative Block (PID) Analog Input Block: 50 ms
Protocol / Communication standard	FOUNDATION Fieldbus protocol that agrees with IEC 61158-2
ITK version	6.1
Physical layer types	Standard power signaling, bus powered, non I.S.
Bus power supply	9...32 VDC (non-Ex); 9...24 VDC (intrinsically-safe)
Basic current	14 mA
Maximum error current	14 mA
Start current after 10 ms	14 mA
Polarity sensitivity	No
Minimum cycle time	250 ms
Output data	Level, distance, ullage conversion, level conversion
Input data	None
Error current FDE	Typically 0 mA (FDE =Fault Disconnection Electronic)
Link Master function	Supported

Display and user interface

User interface options	LCD display (128 × 64 pixels in 8-step greyscale with 4-button keypad)
Languages	9 languages are available: English, German, French, Italian, Spanish, Portuguese, Japanese, Chinese (simplified) and Russian

Approvals and certification

CE	This device fulfils the statutory requirements of the EC directives. The manufacturer certifies successful testing of the product by applying the CE mark.
Vibration resistance	EN 60721-3-4 (1...9 Hz: 3 mm / 10...200 Hz:1g; 10g shock ½sinus: 11 ms)
Explosion protection	
ATEX (Ex ia or Ex d) DEKRA xxATEXxxxx X	Compact version
	II 1/2 G, 2 G Ex ia IIC T6...T2 Ga/Gb or Ex ia IIC T6...T3 (or T2) Gb;
	II 1/2 D, 2 D Ex ia IIIC T90°C Da/Db or Ex ia IIIC T90°C Db IP6X;
	II 1/2 G, 2 G Ex d ia IIC T6...T2 Ga/Gb or Ex d ia IIC T6...T3 (or T2) Gb;
	II 1/2 D, 2 D Ex ia tb IIIC T90°C Da/Db or Ex ia tb IIIC T90°C Db IP6X
	Remote version, transmitter
	II 2 G Ex ia [ia Ga] IIC T6...T4 Gb;
	II 2 D Ex ia [ia Da] IIIC T90°C Db;
	II 2 G Ex d ia [ia Ga] IIC T6...T4 Gb;
	II 2 D Ex ia tb [ia Da] IIIC T90°C Db
	Remote version, sensor
	II 1/2 G Ex ia IIC T6...T2 Ga/Gb
	II 1/2 D Ex ia IIIC T90°C Da/Db
	II 1/2 G Ex ia IIC T6...T2 Gb
II 1/2 D Ex ia IIIC T90°C Db	
ATEX (Ex ic) DEKRA xxATEXxxxx X	Compact version
	II 3 G Ex ic IIC T6...T2 Gc;
	II 3 D Ex ic IIIC T90°C Dc
	Remote version, transmitter
	II 3 G Ex ic [ic] IIC T6...T4 Gc;
	II 3 D Ex ic [ic] IIIC T90°C Dc
	Remote version, sensor
	II 3 G Ex ic IIC T6...T2 Gc;
II 3 D Ex ic IIIC T90°C Dc	

cFMus - Dual Seal-approved	NEC 500 (Division ratings)
	XP-AIS / Cl. I / Div. 1 / Gr. ABCD / T6-T1;
	DIP / Cl. II, III / Div. 1 / Gr. EFG / T6-T1;
	IS / Cl. I, II, III / Div. 1 / Gr. ABCDEFG / T6-T1;
	NI / Cl. I / Div. 2 / Gr. ABCD / T6-T1
	NEC 505 (Zone ratings)
	Cl. I / Zone 0 / AEx d [ia] / IIC / T6-T1;
	Cl. I / Zone 0 / AEx ia / IIC / T6-T1;
	Cl. I / Zone 2 / AEx nA / IIC / T6-T1;
	Zone 20 / AEx ia / IIIC / T90°C
	Zone 20 / AEx tb [ia] / IIIC / T90°C
	Hazardous (Classified) Locations, indoor/outdoor Type 4X and 6P, IP66, Dual Seal
	CEC Section 18 (Zone ratings)
	Cl. I, Zone 0, Ex d [ia], IIC, T6-T1;
	Cl. I, Zone 0, Ex ia, IIC, T6-T1;
	Cl. I, Zone 2, Ex nA, IIC, T6-T1
	CEC Section 18 and Annex J (Division ratings)
	XP-AIS / Cl. I / Div. 1 / Gr. BCD / T6-T1
	DIP / Cl. II, III / Div. 1 / Gr. EFG / T6-T1
	IS / Cl. I / Div. 1 / Gr. BCD / T6-T1
NI / Cl. I / Div. 2 / Gr. ABCD / T6-T1	
NEPSI	Ex ia IIC T2-T6 Gb or Ex ia IIC T2-T6 Ga/Gb DIP A20/A21 T _A T90°C IP6X Ex d ia IIC T2-T6 Gb or Ex d ia IIC T2-T6 Ga/Gb DIP A20/A21 T _A T90°C IP6X
Other standards and approvals	
SIL	Compact version only: SIL 2 - certified according to all the requirements in EN 61508 (Full Assessment) and for high/low demand mode operation. HFT=0, SFF=94.3% (for non-Ex / Ex i devices) or 92.1% (for Ex d devices), type B device
EMC	EMC Directives 2004/108/EC in conjunction with EN 61326-1 (2006). The device agrees with this standard if the time constant ≥ 3 seconds and: - the device has a coaxial probe or - the device has a single / double probe that is installed in a metallic tank. For more data, refer to <i>Electromagnetic compatibility</i> on page 8. SIL 2-approved devices agree with EN 61326-3-1 (2006) and EN 61326-3-2 (2006)
NAMUR	NAMUR NE 21 Electromagnetic Compatibility (EMC) of Industrial Process and Laboratory Control Equipment
	NAMUR NE 43 Standardization of the Signal Level for the Failure Information of Digital Transmitters
	NAMUR NE 53 Software and Hardware of Field Devices and Signal Processing Devices with Digital Electronics
	NAMUR NE 107 Self-Monitoring and Diagnosis of Field Devices
CRN	This certification is applicable for all Canadian provinces and territories. For more data, refer to the website.
Construction code	On request: NACE MR0175 / ISO 15156; NACE MR0103

① HART® is a registered trademark of the HART Communication Foundation

② Only the 3.6 mA error signal is applicable to SIL-approved devices

Probe options

	Single cable Ø2 mm / 0.08"	Single cable Ø4 mm / 0.16"	Single rod Ø8 mm / 0.31"
--	-------------------------------	-------------------------------	-----------------------------

Measuring system

Application	Liquids	Liquids and solids	
Measuring range	1...40 m / 3.3...131 ft	Liquids: 1...40 m / 3.3...131 ft Solids: 1...20 m / 3.3...65.6 ft	1...6 m / 3.3...19.7 ft
Dead zone	This depends on the type of probe. For more data, refer to "Measurement limits" in this chapter. ①		

Measuring accuracy

Accuracy (in direct mode)	Standard: ±10 mm / ±0.4", when distance ≤ 10 m / 33 ft; ±0.1% of measured distance, when distance > 10 m / 33 ft
	Optional: ±3 mm / ±0.1", when distance ≤ 10 m / 33 ft; ±0.03% of measured distance, when distance > 10 m / 33 ft
Accuracy (in TBF mode)	±20 mm / ±0.8"
Resolution	1 mm / 0.04"
Repeatability	±1 mm / ±0.04"
Maximum rate of change at 4 mA	10 m/min / 32.8 ft/min

Operating conditions

Max. temperature at the process connection (also depends on the temperature limits of the gasket material. Refer to "Materials" in this table.)	-50...+300°C / -58...+572°F	-50...+150°C / -58...+302°F
Pressure	-1...40 barg / -14.5...580 psig	
Viscosity (liquids only)	10000 mPa.s / 10000 cP	
Dielectric constant	≥ 1.8 in direct mode; ≥ 1.1 in TBF mode	

Materials

Probe	Stainless steel (1.4404 / 316L)	Stainless steel (1.4401 / 316); Hastelloy® C-22 (2.4602)
Gasket (process seal)	FKM/FPM [-40...+300°C / -40...+572°F]; Kalrez® 6375 [-20...+300°C / -4...+572°F]; EPDM [-50...+250°C / -58...+482°F] ②	FKM/FPM [-40...+150°C / -40...+302°F]; Kalrez® 6375 [-20...+150°C / -4...+302°F]; EPDM [-50...+150°C / -58...+302°F] ②
Process connection	Stainless steel (1.4404 / 316L); Hastelloy® C-22 (2.4602)	

Process connections

Thread	For more data on options, refer to <i>Order code</i> on page 146
Flange	For more data on options, refer to <i>Order code</i> on page 146

① These values are correct when the Dynamic Parasite Rejection (DPR) function is on. The DPR function is set to "on" at the factory.

② Kalrez® is a registered trademark of DuPont Performance Elastomers L.L.C.

	Double cable 2 × Ø4 mm / 0.16"	Double rod 2 × Ø8 mm / 0.31"	Coaxial Ø22 mm / 0.9"
--	-----------------------------------	---------------------------------	--------------------------

Measuring system

Application	Liquids		
Measuring range	1...40 m / 3.3...131 ft	1...4 m / 3.3...13.1 ft	1...6 m / 3.3...19.7 ft
Dead zone	This depends on the type of probe. For more data, refer to "Measurement limits" in this chapter. ①		

Measuring accuracy

Accuracy (in direct mode)	Standard: ± 10 mm / ± 0.4 ", when distance ≤ 10 m / 33 ft; $\pm 0.1\%$ of measured distance, when distance > 10 m / 33 ft Optional: ± 3 mm / ± 0.1 ", when distance ≤ 10 m / 33 ft; $\pm 0.03\%$ of measured distance, when distance > 10 m / 33 ft		
Accuracy (in TBF mode)	± 20 mm / ± 0.8 "		
Resolution	1 mm / 0.04"		
Repeatability	± 1 mm / ± 0.04 "		
Maximum rate of change at 4 mA	10 m/min / 32.8 ft/min		

Operating conditions

Max. temperature at the process connection (also depends on the temperature limits of the gasket material. Refer to "Materials" in this table.)	-50...+150°C / -58...+302°F		
Pressure	-1...40 barg / -14.5...580 psig		
Viscosity (liquids only)	10000 mPa.s / 10000 cP	1500 mPa.s / 1500 cP	500 mPa.s / 500 cP
Dielectric constant	≥ 1.6 in direct mode		≥ 1.4 in direct mode
	≥ 1.1 in TBF mode		

Materials

Probe	Stainless steel (1.4404 / 316L)	Stainless steel (1.4401 / 316); Hastelloy® C-22 (2.4602)
Gasket (process seal)	FKM/FPM (-40...+150°C / -40...+302°F); Kalrez® 6375 (-20...+150°C / -4...+302°F); EPDM (-50...+150°C / -58...+302°F) ②	
Process connection	Stainless steel (1.4404 / 316L); Hastelloy® C-22 (2.4602)	

Process connections

Thread	For more data on options, refer to <i>Order code</i> on page 146
Flange	For more data on options, refer to <i>Order code</i> on page 146

① These values are correct when the Dynamic Parasite Rejection (DPR) function is on. The DPR function is set to "on" at the factory.

② Kalrez® is a registered trademark of DuPont Performance Elastomers L.L.C.

8.3 Minimum power supply voltage

Use these graphs to find the minimum power supply voltage for a given current output load.

Non-Ex and Hazardous Location approved (Ex i / IS) devices

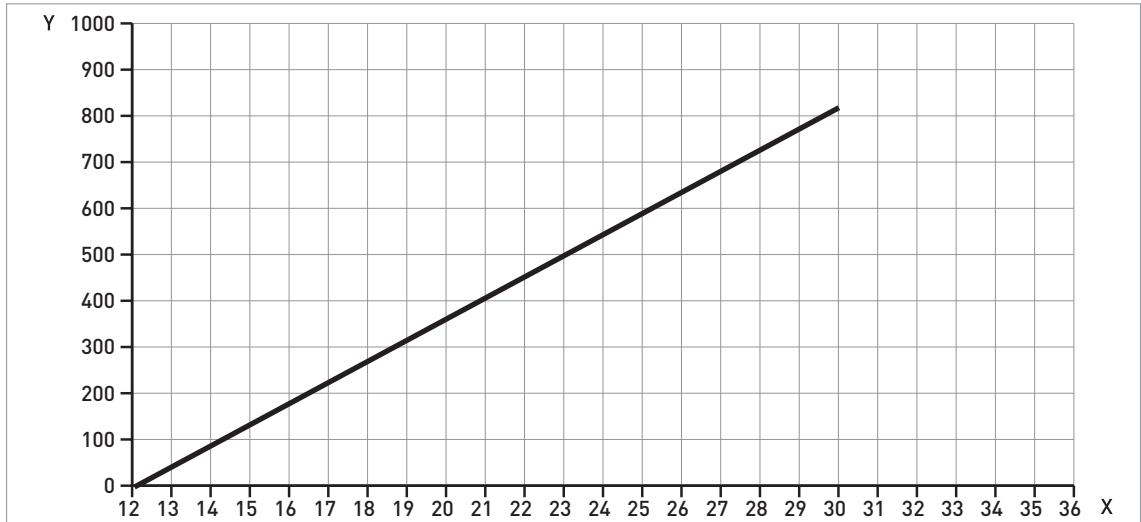

Figure 8-2: Minimum power supply voltage for an output of 22 mA at the terminal (Non-Ex and Hazardous Location approval (Ex i / IS))

X: Power supply U [VDC]
 Y: Current output load R_L [Ω]

Hazardous Location (Ex d / XP/NI) approved devices

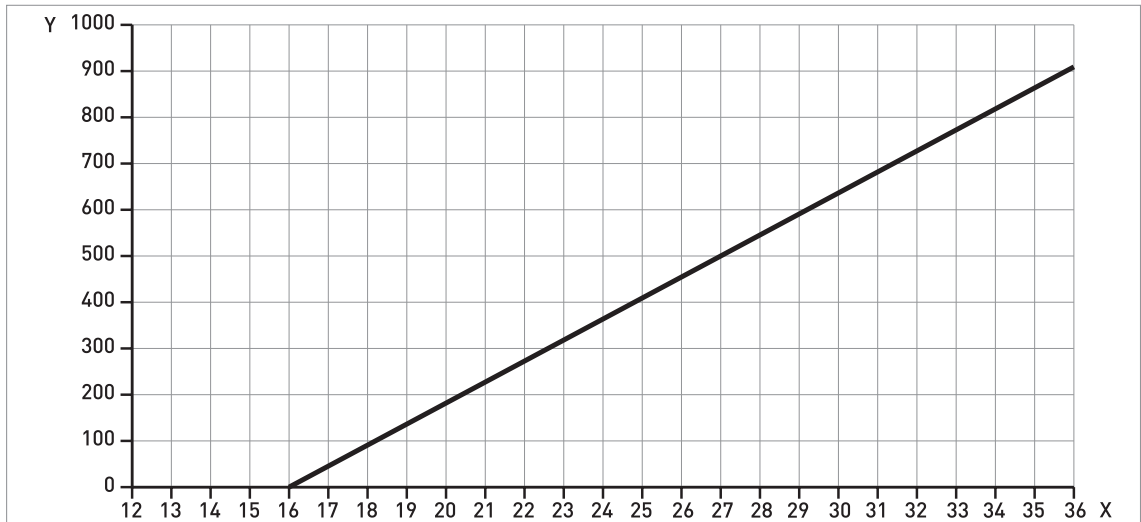

Figure 8-3: Minimum power supply voltage for an output of 22 mA at the terminal (Hazardous Location approval (Ex d / XP/NI))

X: Power supply U [VDC]
 Y: Current output load R_L [Ω]

8.4 Pressure / flange temperature graph for probe selection

Make sure that the transmitters are used within their operating limits. Obey the temperature limits of the process seal and the flange.

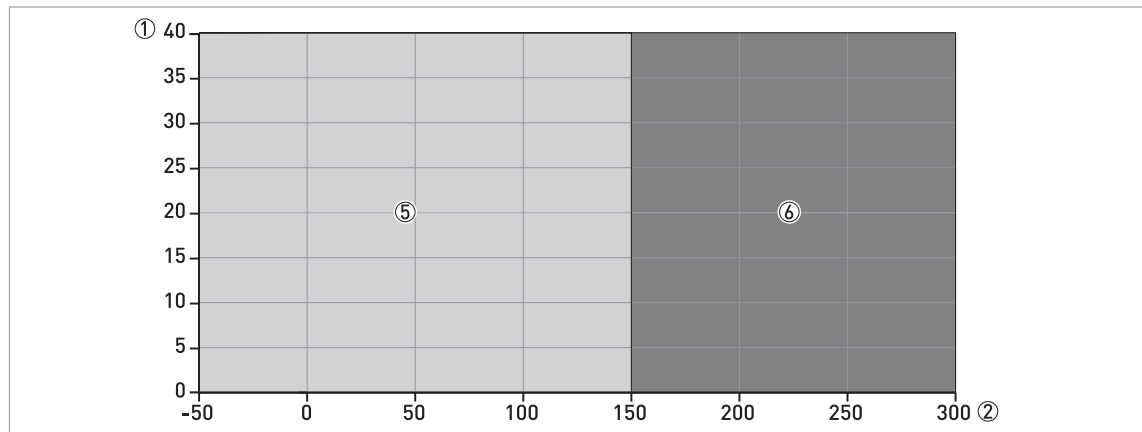

Figure 8-4: Pressure/temperature graph for probe selection in °C and barg

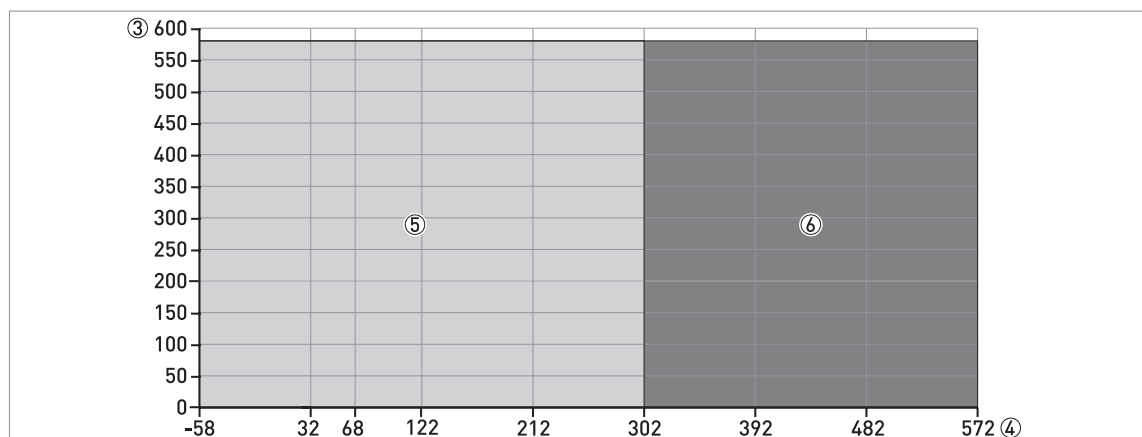

Figure 8-5: Pressure/temperature graph for probe selection in °F and psig

- ① Process pressure, P_s [barg]
- ② Process connection temperature, T [°C]
- ③ Process pressure, P_s [psig]
- ④ Process connection temperature, T [°F]
- ⑤ All probes
- ⑥ High-Temperature (HT) version of the $\varnothing 2$ mm / 0.08" single cable probe



WARNING!

The minimum and maximum process connection temperature and the minimum and maximum process pressure also depends on the gasket material selected. Refer to "Pressure and temperature ranges" on page 18.



INFORMATION!

CRN CERTIFICATION

There is a CRN certification option for devices with process connections that agree with ASME standards. This certification is necessary for all devices that are installed on a pressure vessel and used in Canada. 1" and 1½" ASME flanges are not available for CRN-approved devices.

ASME flanges for CRN-approved devices

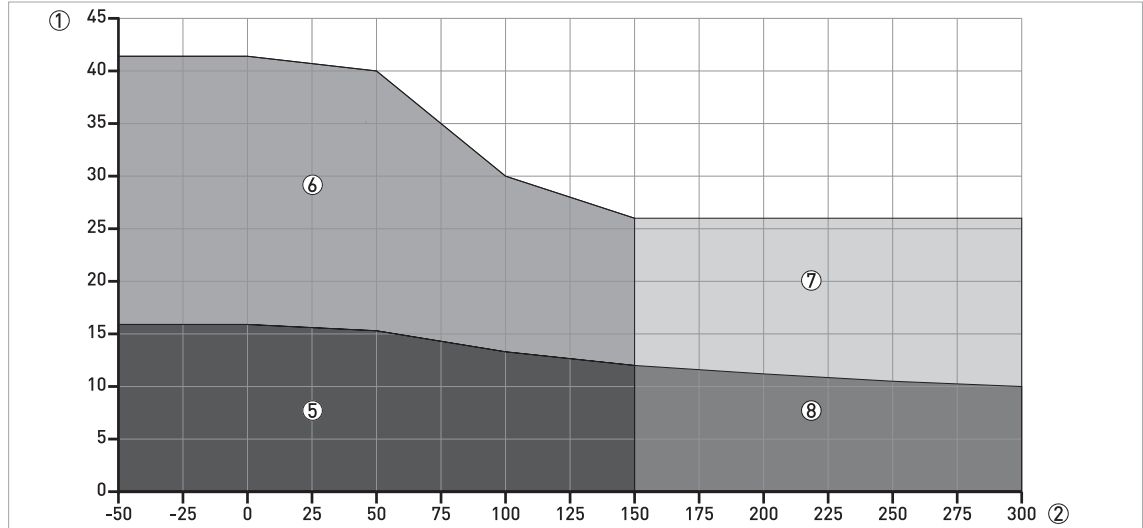

Figure 8-6: Pressure / temperature rating (ASME B16.5), flange and threaded connections, in °C and barg

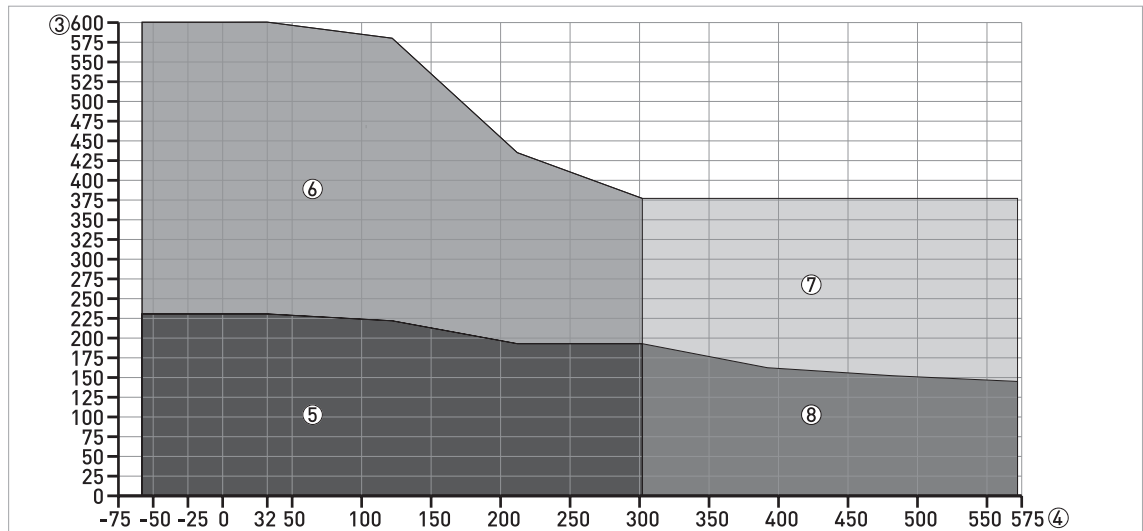

Figure 8-7: Pressure / temperature rating (ASME B16.5), flange and threaded connections, in °F and psig

- ① p [barg]
- ② T [°C]
- ③ p [psig]
- ④ T [°F]
- ⑤ Flange connection, Class 150 / Threaded connections, NPT: All probes
- ⑥ Flange connection, Class 300 / Threaded connections, NPT: All probes
- ⑦ Flange connection, Class 300 / Threaded connections, NPT: High-Temperature (HT) version of the Ø2 mm / 0.08" single cable probe
- ⑧ Flange connection, Class 150 / Threaded connections, NPT: High-Temperature (HT) version of the Ø2 mm / 0.08" single cable probe

8.5 Measurement limits

Double cable and double rod probes

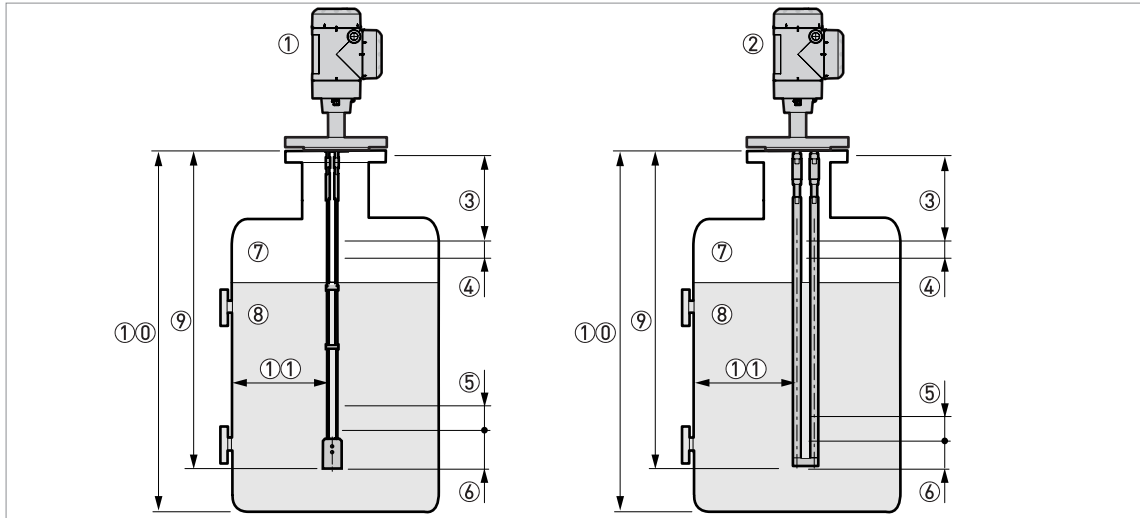

Figure 8-8: Measurement limits

- ① Device with a double cable probe
- ② Device with a double rod probe
- ③ **Top dead zone:** Top part of the probe where measurement is not possible
- ④ **Top non-linearity zone:** Top part of the probe with a lower accuracy of $\pm 30 \text{ mm} / \pm 1.18''$
- ⑤ **Bottom non-linearity zone:** Bottom part of the probe with a lower accuracy of $\pm 30 \text{ mm} / \pm 1.18''$
- ⑥ **Bottom dead zone:** Bottom part of the probe where measurement is not possible
- ⑦ Gas (Air)
- ⑧ Product
- ⑨ L, Probe length
- ⑩ Tank Height
- ⑪ **Minimum distance from the probe to a metallic tank wall:** Double cable or double rod probes = $100 \text{ mm} / 4''$

Measurement limits (dead zone) in mm and inches

Dead zone	$\epsilon_r = 80$				$\epsilon_r = 2.3$			
	Top ③		Bottom ⑥		Top ③		Bottom ⑥	
	[mm]	[inches]	[mm]	[inches]	[mm]	[inches]	[mm]	[inches]
Double cable	200	7.87	80	3.15	300	11.81	80	3.15
Double rod	150	5.91	10	0.39	300	11.81	110	4.33

Measurement limits (non-linearity zone) in mm and inches

Non-linearity zone	$\epsilon_r = 80$				$\epsilon_r = 2.3$			
	Top ④		Bottom ⑤		Top ④		Bottom ⑤	
	[mm]	[inches]	[mm]	[inches]	[mm]	[inches]	[mm]	[inches]
Double cable	50	1.97	20	0.79	0	0	70	2.76
Double rod	120	4.72	30	1.18	0	0	70	2.76

80 is ϵ_r of water; 2.3 is ϵ_r of oil

Single cable and single rod probes

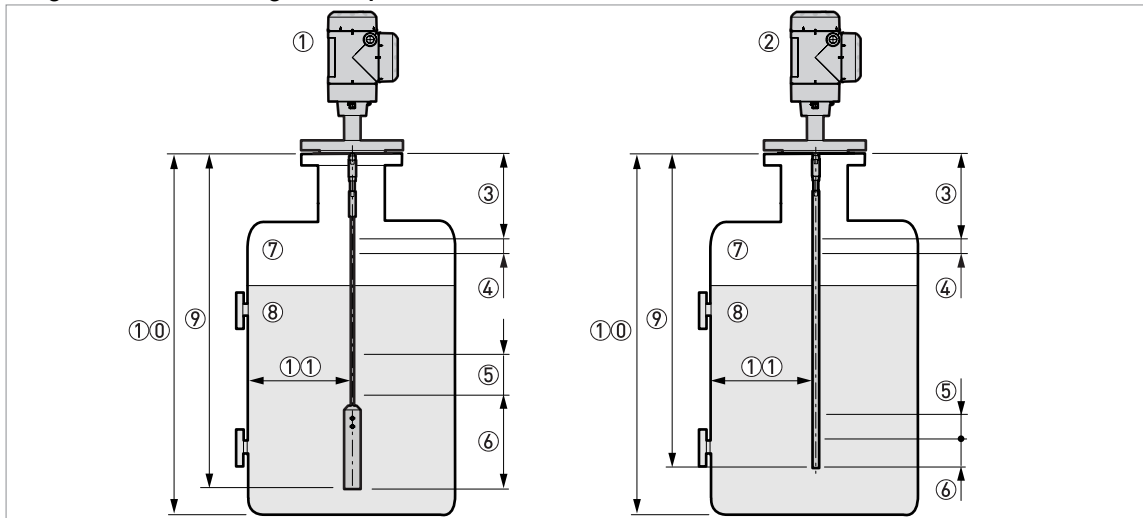

Figure 8-9: Measurement limits

- ① Device with a single cable probe
- ② Device with a single rod probe
- ③ **Top dead zone:** Top part of the probe where measurement is not possible
- ④ **Top non-linearity zone:** Top part of the probe with a lower accuracy of $\pm 30 \text{ mm} / \pm 1.18''$
- ⑤ **Bottom non-linearity zone:** Bottom part of the probe with a lower accuracy of $\pm 30 \text{ mm} / \pm 1.18''$
- ⑥ **Bottom dead zone:** Bottom part of the probe where measurement is not possible
- ⑦ Gas [Air]
- ⑧ Product
- ⑨ L, Probe length
- ⑩ Tank Height
- ⑪ **Minimum distance from the probe to a metallic tank wall:** Single cable or single rod probes = $300 \text{ mm} / 12''$

Measurement limits (dead zone) in mm and inches

Dead zone	$\epsilon_r = 80$				$\epsilon_r = 2.3$			
	Top ③		Bottom ⑥		Top ③		Bottom ⑥	
	[mm]	[inches]	[mm]	[inches]	[mm]	[inches]	[mm]	[inches]
Ø2 mm single cable	250	9.84	200	7.87	350	13.78	250	9.84
Ø4 mm single cable	250	9.84	200	7.87	300	11.81	200	7.87
Single rod	150	5.91	50	1.97	300	11.81	170	6.69

Measurement limits (non-linearity zone) in mm and inches

Non-linearity zone	$\epsilon_r = 80$				$\epsilon_r = 2.3$			
	Top ④		Bottom ⑤		Top ④		Bottom ⑤	
	[mm]	[inches]	[mm]	[inches]	[mm]	[inches]	[mm]	[inches]
Ø2 mm single cable	50	1.97	0	0	0	0	50	1.97
Ø4 mm single cable	50	1.97	0	0	0	0	60	2.36
Single rod	150	5.91	0	0	0	0	0	0

80 is ϵ_r of water; 2.3 is ϵ_r of oil

Coaxial probe

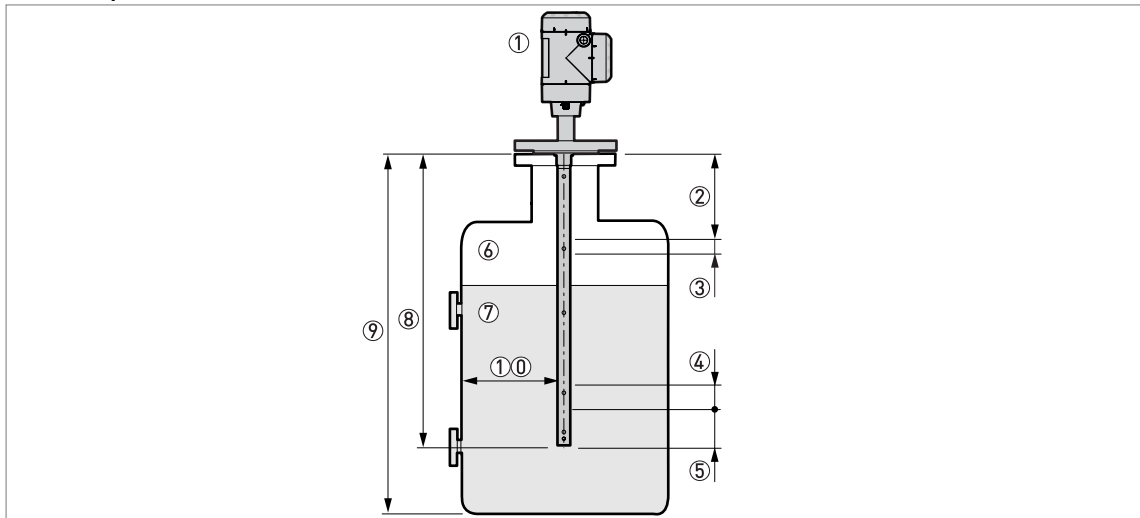

Figure 8-10: Measurement limits

- ① Device with a coaxial probe
- ② **Top dead zone:** Top part of the probe where measurement is not possible
- ③ **Top non-linearity zone:** Top part of the probe with a lower accuracy of $\pm 30 \text{ mm} / \pm 1.18''$
- ④ **Bottom non-linearity zone:** Bottom part of the probe with a lower accuracy of $\pm 30 \text{ mm} / \pm 1.18''$
- ⑤ **Bottom dead zone:** Bottom part of the probe where measurement is not possible
- ⑥ Gas (Air)
- ⑦ Product
- ⑧ L, Probe length
- ⑨ Tank Height
- ⑩ Minimum distance from the probe to a metallic tank wall: Coaxial probe = $0 \text{ mm} / 0''$

Measurement limits (dead zone) in mm and inches

Dead zone	$\epsilon_r = 80$				$\epsilon_r = 2.3$			
	Top ②		Bottom ⑤		Top ②		Bottom ⑤	
	[mm]	[inches]	[mm]	[inches]	[mm]	[inches]	[mm]	[inches]
Coaxial	150	5.91	0	0	200	7.87	20	0.79

Measurement limits (non-linearity zone) in mm and inches

Non-linearity zone	$\epsilon_r = 80$				$\epsilon_r = 2.3$			
	Top ③		Bottom ④		Top ③		Bottom ④	
	[mm]	[inches]	[mm]	[inches]	[mm]	[inches]	[mm]	[inches]
Coaxial	0	0	50	1.97	0	0	150	5.91

80 is ϵ_r of water; 2.3 is ϵ_r of oil

8.6 Dimensions and weights

Housing dimensions

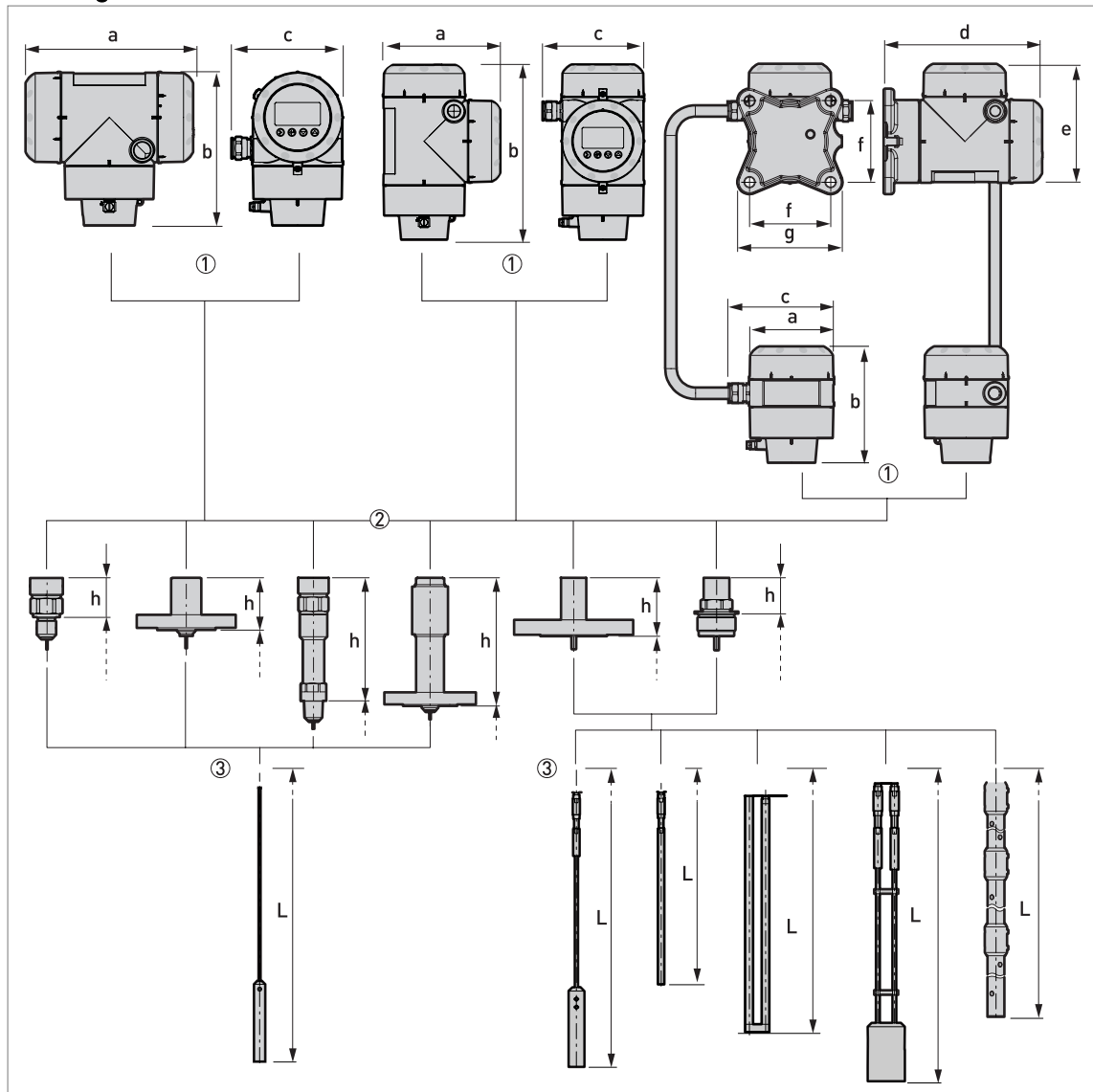

Figure 8-11: Housing dimensions

- ① **Housing options.** From left to right: compact converter with horizontal housing, compact converter with vertical housing, and remote converter (top) and probe housing (bottom)
- ② **Process connection options.** From left to right: threaded connection for $\varnothing 2$ mm / 0.08" single cable probe, flange connection for $\varnothing 2$ mm / 0.08" single cable probe, high-temperature (HT) threaded connection for $\varnothing 2$ mm / 0.08" single cable probe, HT flange connection for $\varnothing 2$ mm / 0.08" single cable probe, flange connection for other probes, threaded connection for other probes
- ③ **Probe options.** From left to right: $\varnothing 2$ mm / 0.08" single cable probe, $\varnothing 4$ mm / 0.16" single cable probe, single rod (single-piece or segmented) probe, double rod probe, $\varnothing 4$ mm / 0.16" double cable probe and coaxial (single-piece or segmented) probe

**INFORMATION!**

All housing covers have bayonet connectors unless it is an explosion-proof (XP / Ex d-approved) device. The terminal compartment cover for explosion-proof devices has a thread with a flame path.

Housing options: Dimensions in mm

Dimensions [mm]	Compact - horizontal		Compact - vertical		Remote	
	Non-Ex / Ex i / IS	Ex d / XP	Non-Ex / Ex i / IS	Ex d / XP	Non-Ex / Ex i / IS	Ex d / XP
a	191	258	147	210	104	104
b	175	175	218	218	142	142
c	127	127	127	127	129	129
d	-	-	-	-	184	184
e	-	-	-	-	163	226
f	-	-	-	-	100	100
g	-	-	-	-	155	155

Housing options: Dimensions in inches

Dimensions [inches]	Compact - horizontal		Compact - vertical		Remote	
	Non-Ex / Ex i / IS	Ex d / XP	Non-Ex / Ex i / IS	Ex d / XP	Non-Ex / Ex i / IS	Ex d / XP
a	7.5	10.2	5.79	8.27	4.09	4.09
b	6.89	6.89	8.23	8.23	5.59	5.59
c	5.00	5.00	5.00	5.00	5.08	5.08
d	-	-	-	-	7.24	7.24
e	-	-	-	-	6.42	8.90
f	-	-	-	-	3.94	3.94
g	-	-	-	-	6.10	6.10

Process connection and probe options: Dimensions in mm

Dimensions [mm]	Probes with threaded connections			Probes with flange connections		
	Ø2 mm single cable probe	HT Ø2 mm single cable probe	Other probes	Ø2 mm single cable probe	HT Ø2 mm single cable probe	Other probes
h	43	169	45	61	186	73
L	For more data, refer to "Single probes" and "Double and coaxial probes" in this section.					

Process connection and probe options: Dimensions in inches

Dimensions [inches]	Probes with threaded connections			Probes with flange connections		
	Ø0.08" single cable probe	HT Ø0.08" single cable probe	Other probes	Ø0.08" single cable probe	HT Ø0.08" single cable probe	Other probes
h	1.69	6.65	1.77	2.40	7.32	2.87
L	For more data, refer to "Single probes" and "Double and coaxial probes" in this section.					

Weather protection option

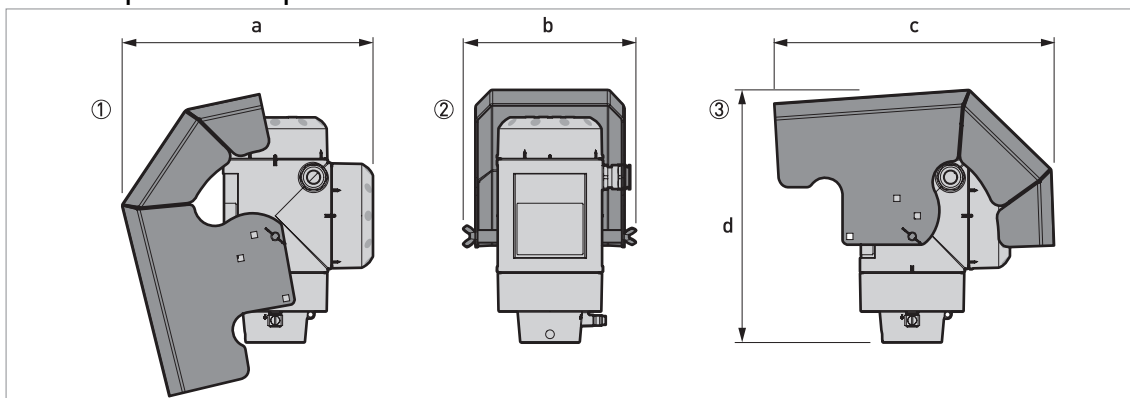

Figure 8-12: Weather protection option for Compact / Vertical and Remote versions

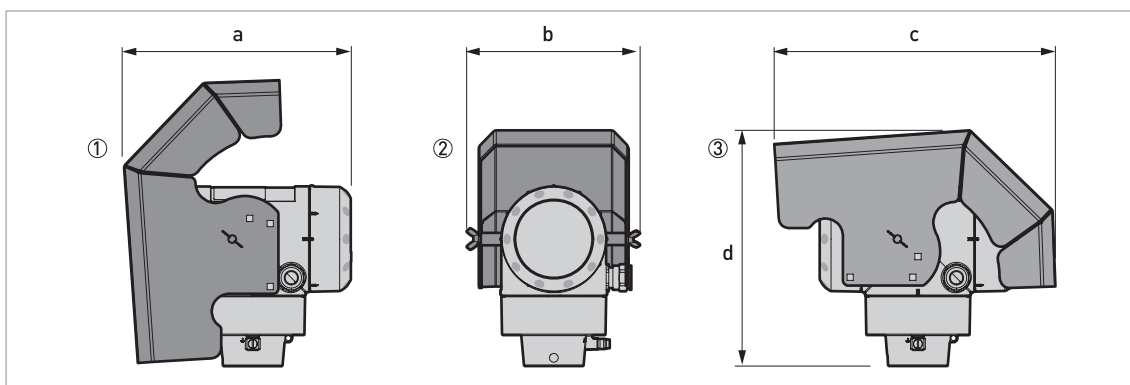

Figure 8-13: Weather protection option for Compact / Horizontal and Remote versions

- ① Left side (with weather protection open)
- ② Rear view (with weather protection closed)
- ③ Right side (with weather protection closed)

Dimensions and weights in mm and kg

Weather protection	Dimensions [mm]				Weights [kg]
	a	b	c	d	
Compact / Vertical or Remote versions	244	170	274	245	1.6
Compact / Horizontal or Remote versions	221	170	274	229	1.6

Dimensions and weights in inches and lb

Weather protection	Dimensions [inches]				Weights [lb]
	a	b	c	d	
Compact / Vertical or Remote versions	9.6	6.7	10.8	9.6	3.5
Compact / Horizontal or Remote versions	8.7	6.7	10.8	9.0	3.5

Single probes

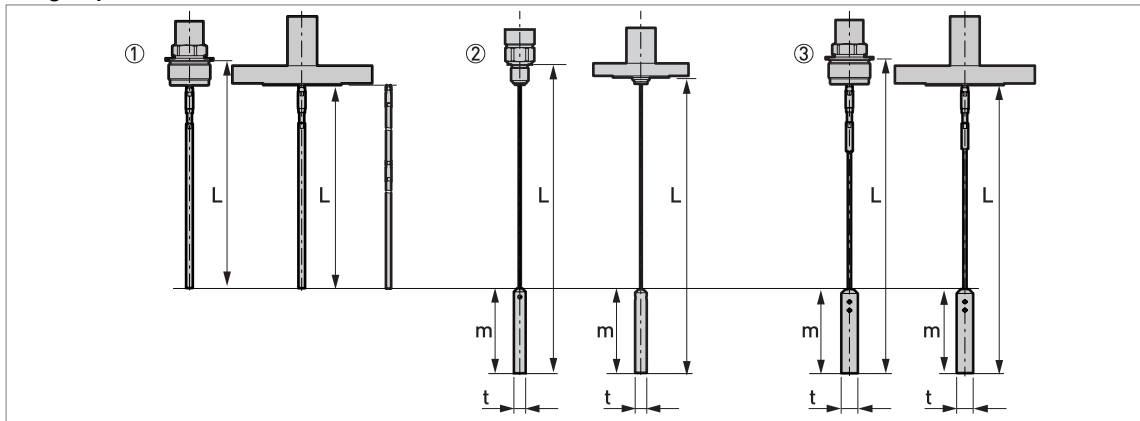

Figure 8-14: Single probe options

- ① Single rod $\varnothing 8$ mm / $\varnothing 0.31$ " (thread and flange versions - segmented probe option shown on the right side)
- ② Single cable $\varnothing 2$ mm / $\varnothing 0.08$ " (thread and flange versions)
- ③ Single cable $\varnothing 4$ mm / $\varnothing 0.16$ " (thread and flange versions)

**INFORMATION!**

A wide range of counterweights and anchoring solutions are available. For dimensional data, refer to the pages that follow. For installation data, refer to How to attach probes to the bottom of the tank on page 23.

Single probes: Dimensions in mm

Probes	Dimensions [mm]			
	L min.	L max.	m	t
Single rod Ø8 mm ①	1000 ②	4000	-	-
Single rod Ø8 mm (segmented) ③	1000 ②	6000	-	-
Single cable Ø2 mm ④	1000 ②	40000	100	Ø14
Single cable Ø4 mm ⑤	1000 ②	40000	100	Ø20

① A device with this probe option must be assembled on site. For the assembly procedure, refer to "How to assemble the single rod probe (single-piece probe)" in the Installation chapter.

② A shorter probe length is available on request

③ A device with this probe option must be assembled on site. For the assembly procedure, refer to "How to assemble the single rod probe (segmented probe)" in the Installation chapter.

④ 1 counterweight option (Ø14×100 mm)

⑤ Refer to the end of this section for data about all the probe end options

Single probes: Dimensions in inches

Probes	Dimensions [inches]			
	L min.	L max.	m	t
Single rod Ø0.31" ①	39 ②	158	-	-
Single rod Ø0.31" (segmented) ③	39 ②	236	-	-
Single cable Ø0.08" ④	39 ②	1575	3.9	0.6
Single cable Ø0.16" ⑤	39 ②	1575	4.0	0.8

① A device with this probe option must be assembled on site. For the assembly procedure, refer to "How to assemble the single rod probe (single-piece probe)" in the Installation chapter.

② A shorter probe length is available on request

③ A device with this probe option must be assembled on site. For the assembly procedure, refer to "How to assemble the single rod probe (segmented probe)" in the Installation chapter.

④ 1 counterweight option (Ø0.6×3.9")

⑤ Refer to the end of this section for data about all the probe end options

Double and coaxial probes

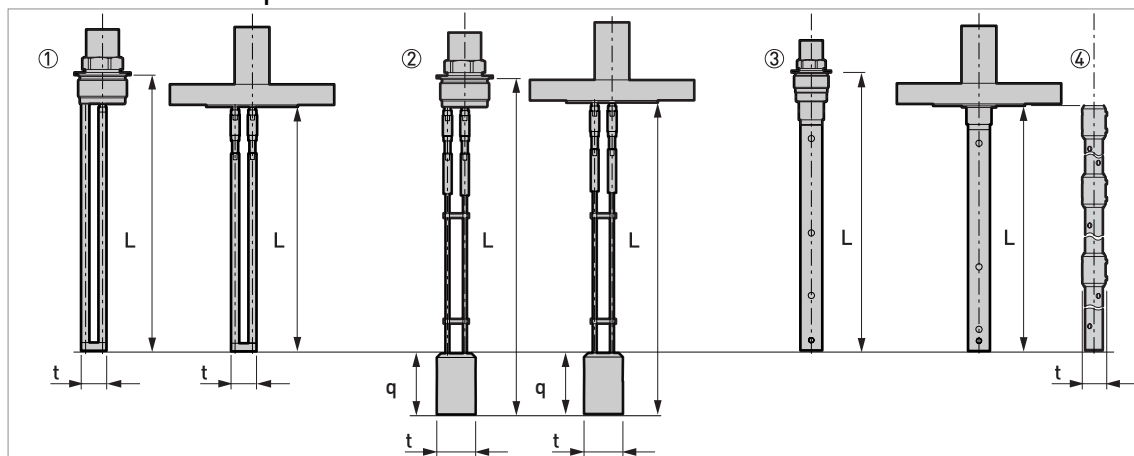

Figure 8-15: Double and coaxial probe options

- ① Double rod $\varnothing 8$ mm / $\varnothing 0.31$ " (thread and flange versions)
- ② Double cable $\varnothing 4$ mm / $\varnothing 0.16$ " (thread and flange versions)
- ③ Coaxial $\varnothing 22$ mm / $\varnothing 0.9$ " (thread and flange versions)
- ④ Coaxial $\varnothing 22$ mm / $\varnothing 0.9$ " (segmented version)



INFORMATION!

A wide range of counterweights and anchoring solutions are available. For dimensional data, refer to the pages that follow. For installation data, refer to How to attach probes to the bottom of the tank on page 23.

Double probes: Dimensions in mm

Probes	Dimensions [mm]			
	L min.	L max.	q	t
Double rod $\varnothing 8$ mm	1000 ①	4000	-	25
Double cable $\varnothing 4$ mm ②	1000 ①	40000	60	$\varnothing 38$
Coaxial $\varnothing 22$ mm	600 ①	6000	-	-
Coaxial $\varnothing 22$ mm (segmented) ③	600 ①	6000	-	$\varnothing 28$

- ① A shorter probe length is available on request
- ② Refer to the end of this section for data about all the probe end options
- ③ A device with this probe option must be assembled on site. For the assembly procedure, refer to "How to assemble the segmented coaxial probe" in the Installation chapter.

Double probes: Dimensions in inches

Probes	Dimensions [inches]			
	L min.	L max.	q	t
Double rod $\varnothing 0.31$ "	39 ①	158	-	1.0
Double cable $\varnothing 0.16$ " ②	39 ①	1575	2.4	$\varnothing 1.5$
Coaxial $\varnothing 0.9$ "	24 ①	236	-	-
Coaxial $\varnothing 0.9$ " (segmented) ③	24 ①	236	-	$\varnothing 1.1$

- ① A shorter probe length is available on request
- ② Refer to the end of this section for data about all the probe end options
- ③ A device with this probe option must be assembled on site. For the assembly procedure, refer to "How to assemble the segmented coaxial probe" in the Installation chapter.

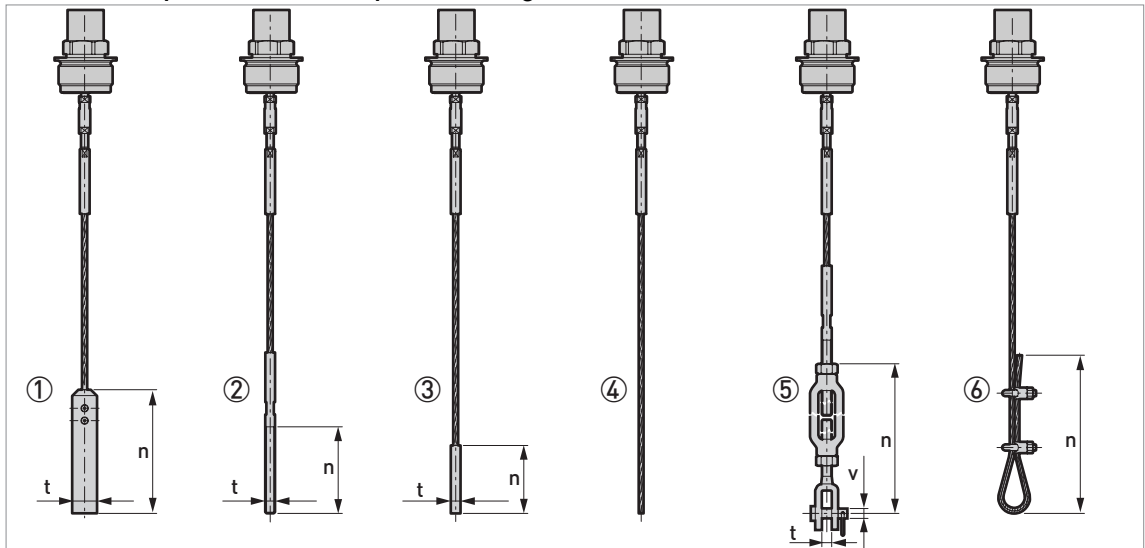
Probe end options for cable probes: single cable $\varnothing 4$ mm/0.15"Figure 8-16: Probe end options for cable probes: single cable $\varnothing 4$ mm/0.15"

- ① Standard counterweight
- ② Threaded end
- ③ Crimped end
- ④ Open end
- ⑤ Turnbuckle
- ⑥ Chuck

Dimensions in mm

Probe end type	Dimensions [mm]		
	n	t	v
Counterweight	100	$\varnothing 20$	-
Threaded end	70	M8	-
Crimped end	55	$\varnothing 8$	-
Open end	-	-	-
Turnbuckle	172 ①	11	$\varnothing 6$
Chuck	300	-	-

① Minimum length

Dimensions in inches

Probe end type	Dimensions [inches]		
	n	t	v
Counterweight	3.9	$\varnothing 0.8$	-
Threaded end	2.8	M8	-
Crimped end	2.2	$\varnothing 0.3$	-
Open end	-	-	-
Turnbuckle	6.8 ①	0.4	$\varnothing 0.2$
Chuck	11.8	-	-

① Minimum length

Probe end options for cable probes: double cable Ø4 mm/0.15"

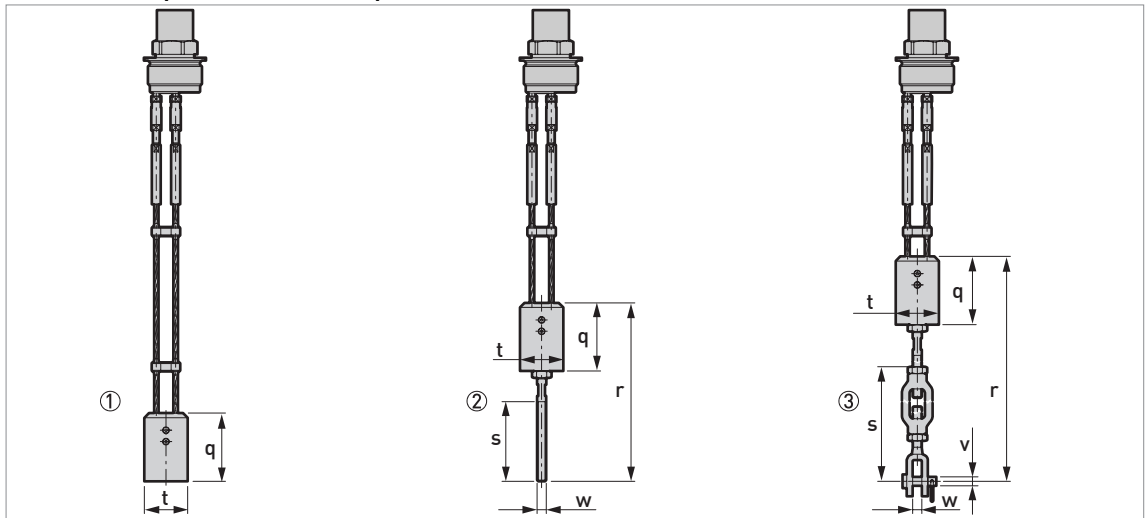

Figure 8-17: Probe end options for cable probes: double cable Ø4 mm/0.15"

- ① Standard counterweight
- ② Threaded end
- ③ Turnbuckle

Dimensions in mm

Probe end type	Dimensions [mm]					
	q	r	s	t	v	w
Counterweight	60	-	-	Ø38	-	-
Threaded end	60	157	70	Ø38	-	M8
Turnbuckle	60	289 ±46	172 ①	Ø38	Ø6	11

① Minimum length

Dimensions in inches

Probe end type	Dimensions [inches]					
	q	r	s	t	v	w
Counterweight	2.4	-	-	Ø1.5	-	-
Threaded end	2.4	6.2	2.8	Ø1.5	-	M8
Turnbuckle	2.4	11.4 ±1.8	6.8 ①	Ø1.5	Ø0.2	0.4

① Minimum length

Converter and probe housing weights

Type of housing	Weights			
	Aluminium housing		Stainless steel housing	
	[kg]	[lb]	[kg]	[lb]

Non-Ex / intrinsically-safe (Ex i / IS)

Type of housing	[kg]	[lb]	[kg]	[lb]
Compact				
Remote converter ①	2.5	5.5	5.9	13.0
Probe housing ①	1.8	4.0	3.9	8.6

Explosion proof (Ex d / XP)

Type of housing	[kg]	[lb]	[kg]	[lb]
Compact	3.2	7.1	7.5	16.5
Remote converter ①	2.9	6.40	7.1	15.65
Probe housing ①	1.8	4.0	3.9	8.6

① The remote version of the device has a "remote converter" and a "probe housing". For more data, refer to "Housing dimensions" at the start of this section.

Probe weights

Probes	Min. process connection size		Weights	
	Thread	Flange	[kg/m]	[lb/ft]
Single cable Ø2 mm / 0.08"	G ½A; ½ NPTF	DN25 PN40; 1" 150 lb; 1½" 300 lb	0.016 ①	0.035 ①
Single cable Ø4 mm / 0.16"	G ¾A; ¾ NPT	DN25 PN40; 1" 150 lb; 1½" 300 lb	0.12 ①	0.08 ①
Double cable Ø4 mm / 0.16"	G 1½A; 1½ NPT	DN50 PN40; 2" 150 lb; 2" 300 lb	0.24 ①	0.16 ①
Single rod Ø8 mm / 0.31"	G ¾A; ¾ NPT	DN25 PN40; 1" 150 lb; 1½" 300 lb	0.41	0.28
Double rod Ø8 mm / 0.31"	G 1½A; 1½ NPT	DN50 PN40; 2" 150 lb; 2" 300 lb	0.82	0.56
Coaxial Ø22 mm / 0.9"	G ¾A; ¾ NPT	DN25 PN40; 1" 150 lb; 1½" 300 lb	0.79	0.53

① This value does not include the weight of the counterweight

9.1 General description

The HART[®] Protocol is an open digital communication protocol for industry. It is free to use by anyone. It is included in the software embedded in signal converters of HART-compatible devices.

There are 2 classes of devices which support the HART[®] Protocol: operating devices and field devices. There are 2 classes of operating devices (Master): PC-supported workstations (Primary Master) and manual control units (Secondary Master). These can be used in control centres and other locations. HART[®] field devices include sensors, converters and actuators. Field devices include 2-wire and 4-wire devices, and also intrinsically-safe versions for use in hazardous areas.

There are 2 primary operation modes for HART-compatible devices: point-to-point mode and multi-drop mode.

If the device is used in point-to-point mode, the HART[®] Protocol uses the Bell 202 Frequency Shift Keying (FSK) standard to put a digital signal on top of the 4...20 mA signal. The connected device sends and receives digital signals that agree with the HART[®] Protocol, and sends analog signals at the same time. Only 1 device can be connected to the signal cable.

If the device is used in multi-drop mode, the network only uses a digital signal that agrees with the HART[®] Protocol. The loop current is set to 4 mA. You can connect a maximum of 15 devices to the signal cable.

An FSK or HART[®] modem is included in field devices and manual control units. It is necessary to have an external modem for PC-supported workstations. The external modem is connected to the serial interface.

9.2 Software description

HART[®] identification codes and revision numbers

Manufacturer ID:	0x45
Device:	
Device Revision:	1
DD Revision	1
HART [®] Universal Revision:	6
FC 375/475 system SW.Rev.:	≥ 2.0
AMS version:	≥ 7.0
PDM version:	≥ 6.0
FDT version:	1.2

9.3 Connection variants

The signal converter is a 2-wire device with 4...20 mA current output and HART[®] interface.

- **Multi-Drop Mode is supported**
In a Multi-Drop communication system, more than 1 device is connected to a common transmission cable.
- **Burst Mode is not supported**

There are two ways of using the HART[®] communication:

- as Point-to-Point connection and
- as Multi-Drop connection with 2-wire connection.

9.3.1 Point-to-Point connection - analogue / digital mode

Point-to-Point connection between the signal converter and the HART[®] Master.

The current output of the device is passive.

Also refer to *Point-to-point networks* on page 57.

9.3.2 Multi-Drop connection (2-wire connection)

Up to 15 devices may be installed in parallel (this signal converter and other HART[®] devices).

For an illustration of multi-drop networks, refer to *Multi-drop networks* on page 58.

For data on communication in multi-drop mode, refer to *HART[®] network configuration* on page 82.

9.4 HART[®] device variables

The HART[®] dynamic variables PV (Primary Variable), SV (Secondary Variable), TV (Third Variable) and 4V (Fourth Variable) can be assigned to any of the device variables.

The HART[®] dynamic variable PV is always connected to the HART[®] current output which is, for example, assigned to level measurement.

9.5 Field Communicator 375/475 (FC 375/475)

The Field Communicator is a hand terminal from Emerson Process Management that is designed to configure HART® and Foundation Fieldbus devices. Device Descriptions (DDs) are used to integrate different devices into the Field Communicator.

9.5.1 Installation

**CAUTION!**

The Field Communicator cannot be used to correctly configure, operate or read data from the device unless the Device Description (DD) file is installed.

System and software requirements for the Field Communicator

- System card that includes the "Easy Upgrade Option"
- Field Communicator Easy Upgrade Programming Utility
- HART® Device Description file

For more data, refer to the Field Communicator User's Manual.

9.5.2 Operation

**INFORMATION!**

The Field Communicator will not give you access to the service menu. A simulation is only possible for current outputs.

The Field Communicator and the device's local display use almost the same procedures to operate the signal converter. The online help for each menu item refers to the function number given to each menu item on the local device display. Protection of settings is the same as on the device's local display.

The Field Communicator always saves a complete configuration for communication with AMS.

For more data, refer to *HART®* menu tree for Basic-DD on page 139.

9.6 Asset Management Solutions (AMS)

The Asset Management Solutions Device Manager (AMS) is a PC program from Emerson Process Management which is designed to configure and manage HART[®], PROFIBUS and Foundation-Fieldbus devices. Device Descriptions (DDs) are used to integrate different devices into the AMS.

9.6.1 Installation

Please read the README.TXT file in the Installation Kit.

If the Device Description has not been installed at this time, install the Installation Kit HART[®] AMS. This .EXE file is given on the DVD-ROM  supplied with the device. You can also download the file from our website.

For installation data, refer to the "AMS Intelligent Device Manager Books Online" section "Basic AMS Functionality > Device Configurations > Installing Device Types > Procedures > Install device types from media".

9.6.2 Operation



INFORMATION!

For more data, refer to HART[®] menu tree for AMS on page 141.



9.6.3 Parameter for the basic configuration

Due to AMS requirements and conventions, there are differences when operating the signal converter with AMS and operating using the local keyboard. The service menu parameters are not supported and simulation is only possible for current outputs. The online help for each parameter contains its function number as a reference to the local device display.

9.7 Field Device Tool / Device Type Manager (FDT / DTM)

A Field Device Tool Container (FDT Container) is a PC program used to configure HART[®], PROFIBUS and Foundation Fieldbus devices. To configure a device, an FDT container uses the applicable Device Type Manager (DTM).

9.7.1 Installation

Before you operate the device, the Device Type Manager (Device DTM) must be installed in the Field Device Tool Container. This .msi file is given on the DVD-ROM  supplied with the device. You can also download the file from our website. For installation and configuration data, refer to the documentation that is supplied with the Device DTM on the DVD-ROM or in the "Downloads"  section of the website.

9.7.2 Operation

The DTM and the device's local display use almost the same procedures to operate the signal converter. For more data, refer to *Operation* on page 66.

9.8 Process Device Manager (PDM)

The Process Device Manager (PDM) is a Siemens PC program designed to configure HART® and PROFIBUS devices. Device Descriptions (DDs) are used to integrate different devices into the PDM.

9.8.1 Installation

Install Device Description files supplied in the Device Install HART® PDM folder. This is necessary for each type of field device that is used with SIMATIC PDM. This folder is available for download from the website or on the DVD-ROM supplied with the device. 

If you use PDM version 5.2, refer to PDM manual, section 11.1 - Install device / Integrate device into SIMATIC PDM with Device Install.

If you use PDM version 6.0, refer to PDM manual, section 13 - Integrating devices.

For more data, refer to "readme.txt". You can find this file in the Installation Kit.

9.8.2 Operation



INFORMATION!

For more data, refer to HART® menu tree for PDM on page 143.

There can be differences between the names of menus in the SIMATIC PDM software tool and menus shown on the device display screen. Refer to the online help in SIMATIC PDM to find the function number of each menu item. This function number agrees with the function number in the device menus.

Use the same procedure for the protection of parameters in the supervisor menu.

9.9 HART[®] menu tree for Basic-DD

Abbreviations of the following tables:

- ^{Opt} Optional, depending on device version and configuration
- Rd Read only
- ^{Cust} Custody lock protection
- ^{Loc} Local, affects only DD host views

9.9.1 Overview Basic-DD menu tree (positions in menu tree)

1 Measurements	1 Measurements	
	2 Output	
2 Configuration and Test	1 Info.	1 Identification
		2 Output
	2 Supervisor	1 Test
		2 Basis Parameters
		3 Signal Out
		4 Application
		5 Display
6 Conversion Table		
7 Reset		
3 Diag/Service	1 Status	1 Standard Status
		2 Device-specific Status
4 Access Rights	1 Access level	
	2 Method Login	
	3 Method entry Code	
5 HART variables		

9.9.2 Basic-DD menu tree (details for settings)

1 Measurements

1 Measurements	1 Level value Rd / 2 Distance value Rd / 3 Volume value Rd / 4 Ullage value Rd
2 Inputs/Outputs	1 PV Rd / 2 PV Loop Current Rd / 3 PV % range Rd

2 Configuration and Test

1 Info.	1 Identification	1 Serial Number Rd / 2 Converter Firmware Version Rd / 3 Sensor Firmware Version Rd / 4 HMI Firmware Version Rd
	2 Output	1 Function I Rd / 2 Output Range Rd / 3 PV URV Rd / 4 PV LRV Rd / 5 Output Error Delay Rd

2 Supervisor	1 Test	1 Test I
	2 Basic Parameters	1 Tank height / 2 Time Constant / 3 Probe Length / 4 Block distance / 5 Length Unit (HART) / 6 Volume Unit (HART)
	3 Signal Out	1 Function I / 2 Output Range / 3 PV LRV / 4 PV URV / 5 Output Error Delay / 6 Current Ouput Calibration ^{Cust}
	4 Application	1 Tracing Velocity / 2 Auto product epsilon R / 3 Epsilon R gas / 4 Epsilon R product / 5 Watch Pulses / 6 Measurement Threshold / 7 Probe End Threshold
	5 Display	1 Language / 2 Display Length Unit / 3 Display Volume Unit
	6 Conversion Table	1 Input table / 2 Delete table
	7 Reset	1 Warm start / 2 Factory reset / 3 Reset Configuration Changed flag

3 Diag/Service

1 Status	1 Standard status	1 Device status Rd / 2 Write protect Rd	
	2 Device-specific status	1 Device failures	1 Error Rd / 2 Error Rd / 3 Error Rd
		2 Device warning maintenance required	1 Warning Rd
		3 Device warning out of specification	1 Warning Rd
		4 Info	1 Info Rd

4 Access Rights

1 Access Level	{Access Not Granted}
2 Method Login	1 No Access (Log Out) / 2 Supervisor (Normal User) / 3 Service
3 Method Entry Code	

5 HART variables

	1 Poll addr / 2 Tag / 3 Hardware rev Rd / 4 Software rev Rd / 5 Descriptor / 6 Date / 7 Message / 8 Manufacturer Rd / 9 Model Rd / Dev id Rd / Universal id Rd / Fld dev rev Rd / Num req preams Rd / Num resp preams Rd / Write protect Rd / Production number Rd / Final asmbly num Rd / PV is / SV is / TV is / QV is
--	--

9.10 HART[®] menu tree for AMS

Abbreviations of the following tables:

- ^{Opt} Optional, depending on device version and configuration
- Rd Read only
- ^{Cust} Custody lock protection
- ^{Loc} Local AMS, affects only AMS views

9.10.1 Overview AMS menu tree (positions in menu tree)

Process variables	Measurements	
	Analog Output	
Device Diagnostics	Overview	
	Fatal Errors	
	Warnings (Maintenance required)	
	Warnings (Out of specifications)	
	Warnings (Function check)	
Methods	Access Right	
	Tests	
	Calibrate	
	Threshold Settings	
	Conversion Table	
	Master reset	
Configure / Setup	Basic Setup	Basic Parameters
		Local Display
		Application
	Analog Output	Output Functions
		Output 1
	Units	
	Device	
	HART	ID
		-
	Conversion table	

9.10.2 AMS menu tree (details for settings)

Process Variables

Measurements	Level Rd / Distance Rd / Volume/Mass/Flow Rd / Volume/Mass/Flow Rd / Ullage Volume/Mass/Flow Rd
Analog Output	Analog Output Value Rd / PV Percent of Range Rd

Device Diagnostics

Overview	Primary variable out of limits / Non-primary variable out of limits / Primary variable analog output saturated / Primary variable analog output fixed / Cold Start / Configuration changed / Field device malfunction
Fatal Errors	Converter EEPROM error / Converter RAM error / Converter ROM error / Sensor EEPROM error / Sensor RAM error / Sensor ROM error / Current output drift / Oscillator frequency fail. / Converter Voltage error / Sensor Voltage error / Measurement old/Communicat. Error / Temperature out of range / Sensor not compatible / Sensor processing failure / Reference pulse lost / Level pulse lost error / Interface Lost error / Overfill error / Tank empty error
Warnings (Maintenance required)	Flange lost / Reference position outside range / Audio signal offset outside range / Temperature below -35°C / Temperature above +75°C / Automatic probe length invalid
Warnings (Out of specifications)	Temperature out of range (warning) / Level lost (warning) / Overfill (warning) / Tank empty (warning)
Warnings (Function check)	Local operation on the device
Information	Epsilon R calcul frozen / Epsilon R value low / Epsilon R value high / Temperature out of range for HMI

Methods

Access right	Log In/Log Out / Password Yes/No
Tests	Test Output I
Calibrate	D/A Trim
Threshold Settings	Watch Pulses
Conversion Table	Input table / Delete table
Master reset	Restart Device / Reset Factory / Rst Conf. Chged flag

Configure / Setup

Basic Setup	Basic Parameters	Tank Height / Time Constant / Probe Length / Blocking Distance / Measuring mode Rd / Tag
	Local Display	Display length unit / Display volume unit / Language
	Application	Tracing velocity / Auto product epsilon R / Epsilon R gas / Epsilon R product / Level Threshold / Probe end Threshold
Analog Output	Output Functions	Function I / SV / TV / QV
	Output 1	Output Range / Output Error Delay / LRV / URV
Units	Length unit (HART) / Volume unit (HART) / Time constant	

Device	Model / Manufacturer / Fld dev rev / Software rev / Write protect / Interface option Rd / Descriptor / Message / Date / Serial number / Converter firmware number / Sensor Firmware number / HMI Firmware version	
HART	ID	Tag / Polling address / Device ID
		Universal revision / Fld dev rev Num / Num request preams
Conversion table	Number of points / Length unit Rd / Conversion unit Rd / Points (1...30 level-conversion pairs)	

9.11 HART[®] menu tree for PDM

Abbreviations of the following tables:

- ^{Opt} Optional, depending on device version and configuration
- Rd Read only
- ^{Cust} Custody lock protection
- ^{Loc} Local PDM, affects only PDM views

9.11.1 Overview PDM menu tree (positions in menu tree)

Overview: Menu Device

Communication Path
Download To Device...
Upload To PG/PC...
Update Diagnosis Status
Configuration and Test
Access Rights
watch status

Overview: Menu View

Measurements	Level Value
	Distance Value
Yt diagram	
Diag / Service	
Toolbar	
Status Bar	
Update	

Overview: PDM parameters

Configuration and Test	Info.	Identification
		Output
	Supervisor	Test
		Basic Parameters
		Signal Output
		Application
		Display
		Conversion Table
	Reset	
Access rights		
HART variables		

9.11.2 PDM menu tree (details for settings)

Device Menu

Communication Path

Download To Device...

Upload To PG/PC...

Update Diagnosis Status

Configuration and Test

Info.	Identification	Serial Number Rd / Converter Firmware version Rd / Sensor Firmware version Rd / HMI Firmware version Rd
	Output	Function I Rd / Output Range Rd / PV URV Rd / PV LRV Rd / Output Error Delay Rd
Supervisor	Test	Test I
	Basic Parameters	Tank Height / Time Constant / Probe Length / Blocking Distance / Length Unit (HART) / Volume Unit (HART)
	Signal Output	Function I / Output Range / PV URV / PV LRV / Output Error Delay / Current Output Calibration ①
	Application	Tracing Velocity / Auto product epsilon R / Epsilon R gas / Epsilon R product / Watch Pulses / Level Threshold / Probe End Threshold ②
	Display	Language / Display Length Unit / Display Volume Unit
	Conversion Table	Input Table / Delete Table
	Reset	Warm start (function to restart the device) / Factory Reset / Reset Configuration Changed Flag

Access rights

Access level Rd
Method Login

Method Entry Code

HART Variables

1 Poll addr / 2 Tag / 3 Hardware rev Rd / 4 Software rev Rd / 5 Descriptor / 6 Date / 7 Message / 8 Manufacturer Rd / 9 Model Rd / Dev id Rd / Universal id Rd / Fld dev rev Rd / Num req preams Rd / Num resp preams Rd / Write protect Rd / Production number Rd / Final asbly num Rd / PV is / SV is / TV is / QV is
--

- ① Current Output Calibration is available only if the service password is used
 ② Use "Watch Pulses" to monitor the amplitude of the measured pulses

View Menu

Measurements

Measurements	Level Value / Distance Value
Output	Level value / Loop curent / % Range

Yt diagram

Diag / Service

Standard Status	Device status	PV Analog Channel Saturated / Configuration changed
Device-specific status	Device failures	Oscillator Frequency Failure / Current Output Drift / Sensor ROM error / Sensor RAM error / Sensor EEPROM error / Converter ROM error / Converter RAM error / Converter EEPROM error Sensor No Signal / Sensor Not Compatible / Temperature Out of Range / Measurement Old / Sensor Voltage Error / Converter Voltage Error Reference Pulse Lost / Level Pulse Lost Error / Interface Lost Error / Overfill Error / No Probe Detected
	Device Warning (Out of Specification)	Flange Lost / Leve Lost Warning / Interface Lost Warning / Overfill Warning
	Info	First Start / EpsilonR Calcul Frozen / EpsilonR Value Low / EpsilonR Value High / Temperature out of range for HMI

Toolbar

Status Bar

Update

10.1 Order code

Make a selection from each column to get the full order code. The characters of the order code highlighted in light grey describe the standard.

	4	VF2 2-wire loop-powered Guided Radar (TDR) level meter:
		Housing material
	1	Compact (Aluminium housing)
	2	Compact (Stainless Steel housing)
	3	Sensor (Aluminium housing) with Remote electronic (Aluminium housing)
	4	Sensor (Stainless Steel housing) with Remote electronic (Stainless Steel housing)
	5	Sensor (Stainless Steel housing) with Remote electronic (Aluminium housing)
		Approval ①
	0	Without
	1	ATEX Ex ia IIC T2...T6 + DIP ②
	2	ATEX Ex d ia IIC T2...T6 + DIP ②
	4	ATEX Ex ic IIC T2...T6 + DIP (Zone 2 and 22) - Pending ②
	6	IECEX Ex ia IIC T2...T6 + DIP ②
	7	IECEX Ex d ia IIC T2...T6 + DIP ②
	8	IECEX Ex ic IIC T2...T6 + DIP (Zone 2 and 22) - Pending ②
	A	cFMus IS Cl. I/II/III Div. 1 Gr. A-G; Cl. I Zone 0/20, Ex ia IIC/IIIC T2...T6
	B	cFMus IS-XP/DIP Cl. I/II/III Div. 1, Gr. A-G (A not for Canada); Cl. I Zone 0/20, Ex d/tb IIC/IIIC T2...T6
	C	cFMus NI Cl. I/II/III Div. 2, Gr. A-G; Cl. I Zone 2, Ex nA IIC T2...T6
	L	NEPSI Ex ia IIC T2-T6 + DIP
	M	NEPSI Ex d ia IIC T2-T6 + DIP
		Other approval
	0	Without
	1	SIL2 (for the compact version (C) with a 4...20 mA output only) - Pending
	4	CRN (Canadian Registration Number) - Pending
	5	CRN + SIL2 (for the compact version (C) with a 4...20 mA output only) - Pending
		Process seal (temperature / pressure / material / notes)
	0	Without
	1	-40...+150°C (-40...+302°F) / -1...40 barg (-14.5...580 psig) / FKM/FPM (Viton) - for all probes
	2	-20...+150°C (-4...+302°F) / -1...40 barg (-14.5...580 psig) / Kalrez® 6375 - for all probes
	3	-50...+150°C (-58...+302°F) / -1...40 barg (-14.5...580 psig) / EPDM - for all probes
	6	-40...+300°C (-40...+572°F) / -1...40 barg (-14.5...580 psig) / FKM/FPM (Viton) - only for the HT version of the Ø2 mm single cable probe
	7	-20...+300°C (-4...+572°F) / -1...40 barg (-14.5...580 psig) / Kalrez® 6375 - only for the HT version of the Ø2 mm single cable probe
	8	-50...+250°C (-58...+482°F) / -1...40 barg (-14.5...580 psig) / EPDM - only for the HT version of the Ø2 mm single cable probe
VF2	4	Order code (complete this code on the pages that follow)

										P	1	A	6" 150 lb RF
										P	2	A	6" 300 lb RF (for non-Ex devices only)
										R	1	A	8" 150 lb RF
										R	2	A	8" 300 lb RF (for non-Ex devices only)
										JIS B2220 Flanges			
										G	U	P	40A JIS 10K RF
										H	U	P	50A JIS 10K RF
										L	U	P	80A JIS 10K RF
										M	U	P	100A JIS 10K RF
										P	U	P	150A JIS 10K RF
										R	U	P	200A JIS 10K RF
										Alternative flange faces			
										2	Form B2, EN 1092-1 (surface roughness must be specified in the order)		
										3	Form C, EN 1092-1 (Tongue)		
										4	Form D, EN 1092-1 (Groove)		
										5	Form E, EN 1092-1 (Male)		
										6	Form F, EN 1092-1 (Female)		
										B	FF, ASME B16.5 (Flat face)		
										M	RJ, ASME B16.5 (Ring joint)		
										C	LG, ASME B16.5 (Large groove)		
										D	LF, ASME B16.5 (Large female)		
										E	LT, ASME B16.5 (Large tongue)		
										F	LM, ASME B16.5 (Large male)		
										G	SG, ASME B16.5 (Small groove)		
										H	SF, ASME B16.5 (Small female)		
										K	ST, ASME B16.5 (Small tongue)		
										L	SM, ASME B16.5 (Small male)		
										Output			
										1	2-wire / 4...20 mA passive HART		
										2	2-wire / FOUNDATION™ fieldbus - Pending		
										3	2-wire / PROFIBUS PA - Pending		
										Cable entry / cable gland			
										0	Without		
										1	M20×1.5 / Without		
										2	M20×1.5 / Plastic		
										3	M20×1.5 / Brass		
										4	M20×1.5 / Stainless steel		
										A	½ NPT (brass) / Without		
										B	½ NPT (stainless steel) / Without		
VF2	4									Order code (complete this code on the pages that follow)			

10.2 Spare parts

We supply spare parts for this device. When you send an order for a mechanical spare part, use the reference numbers in the table that follows. When you send an order for an electronic spare part, refer to *Order code* on page 146 and use the VF20VF2 order code.

Mechanical spare parts

XF2	4	0	0	0	VF2 2-wire loop-powered Guided Radar (TDR) level meter:
					Process seal (temperature / pressure / material / notes)
				0	Without
				1	-40...+150°C (-40...+302°F) / -1...40 barg (-14.5...580 psig) / FKM/FPM (Viton) - for all probes
				2	-20...+150°C (-4...+302°F) / -1...40 barg (-14.5...580 psig) / Kalrez® 6375 - for all probes
				3	-50...+150°C (-58...+302°F) / -1...40 barg (-14.5...580 psig) / EPDM - for all probes
				6	-40...+300°C (-40...+572°F) / -1...40 barg (-14.5...580 psig) / FKM/FPM (Viton) - only for the HT version of the Ø2 mm single cable probe
				7	-20...+300°C (-4...+572°F) / -1...40 barg (-14.5...580 psig) / Kalrez® 6375 - only for the HT version of the Ø2 mm single cable probe
				8	-50...+250°C (-58...+482°F) / -1...40 barg (-14.5...580 psig) / EPDM - only for the HT version of the Ø2 mm single cable probe
					Probe (probe type / material / measuring range)
				0	Without
					For liquids only
				2	Single rod - Ø8 mm (0.31") segmented / 316L - 1.4404 / 1...6 m (1.97...19.69 ft)
				3	Single cable - Ø2 mm (0.08") / 316 - 1.4401 / 1...40 m (1.97...131.23 ft)
				6	Double rod - 2xØ8 mm (0.31") / 316L - 1.4404 / 1...4 m (1.97...13.12 ft)
				7	Double cable - 2xØ4 mm (0.16") / 316 - 1.4401 / 1...40 m (1.97...131.23 ft)
				D	Single cable - Ø2 mm (0.08") / Hastelloy® C22® / 1...40 m (1.97...131.23 ft)
				A	Coax - Ø22 mm (0.87") / 316L - 1.4404 / 0.6...6 m (0.98...19.69 ft)
				B	Coax - Ø22 mm (0.87") segmented / 316L - 1.4404 / 0.6...6 m (0.98...19.69 ft)
				E	Coax - Ø22 mm (0.87") / Hastelloy® C22® / 0.6...6 m (0.98...19.69 ft)
					For liquids and solids
				1	Single rod - Ø8 mm (0.31") / 316L - 1.4404 / 1...6 m (1.97...19.69 ft)
				4	Single cable - Ø4 mm (0.16") / 316 - 1.4401 / liquids: 1...40 m (1.97...131.23 ft); solids: 1...20 m (1.97...65.92 ft)
					Probe connection without probe
				K	Probe connection (316L - 1.4404) for single rod or single cable probe - probe not included - not available for single cable Ø2 mm (0.08")
				L	Probe connection (316L - 1.4404) for double rod or double cable probe - probe not included
XF2	4	0	0	0	Order code (complete this code on the pages that follow)

								M	D	1	DN100 PN10 - Form B1 flange
								M	E	1	DN100 PN16 - Form B1 flange
								M	F	1	DN100 PN25 - Form B1 flange
								M	G	1	DN100 PN40 - Form B1 flange
								P	D	1	DN150 PN10 - Form B1 flange
								P	E	1	DN150 PN16 - Form B1 flange
								P	F	1	DN150 PN25 - Form B1 flange
								P	G	1	DN150 PN40 - Form B1 flange (for non-Ex devices only)
								R	E	1	DN200 PN16 - Form B1 flange
								R	G	1	DN200 PN40 - Form B1 flange (for non-Ex devices only)
								ASME B16.5 / ANSI Flanges ④			
								E	1	A	1" 150 lb RF ②
								E	2	A	1" 300 lb RF ②
								G	1	A	1½" 150 lb RF
								G	2	A	1½" 300 lb RF
								H	1	A	2" 150 lb RF
								H	2	A	2" 300 lb RF
								L	1	A	3" 150 lb RF
								L	2	A	3" 300 lb RF
								M	1	A	4" 150 lb RF
								M	2	A	4" 300 lb RF
								P	1	A	6" 150 lb RF
								P	2	A	6" 300 lb RF (for non-Ex devices only)
								R	1	A	8" 150 lb RF
								R	2	A	8" 300 lb RF (for non-Ex devices only)
								JIS B2220 Flanges			
								G	U	P	40A JIS 10K RF
								H	U	P	50A JIS 10K RF
								L	U	P	80A JIS 10K RF
								M	U	P	100A JIS 10K RF
								P	U	P	150A JIS 10K RF
								R	U	P	200A JIS 10K RF
								Alternative flange faces			
								2	Form B2, EN 1092-1 (surface roughness must be specified in the order)		
								3	Form C, EN 1092-1 (Tongue)		
								4	Form D, EN 1092-1 (Groove)		
								5	Form E, EN 1092-1 (Male)		
								6	Form F, EN 1092-1 (Female)		
XF2	4	0	0	0				Order code (complete this code on the pages that follow)			

Other spare parts

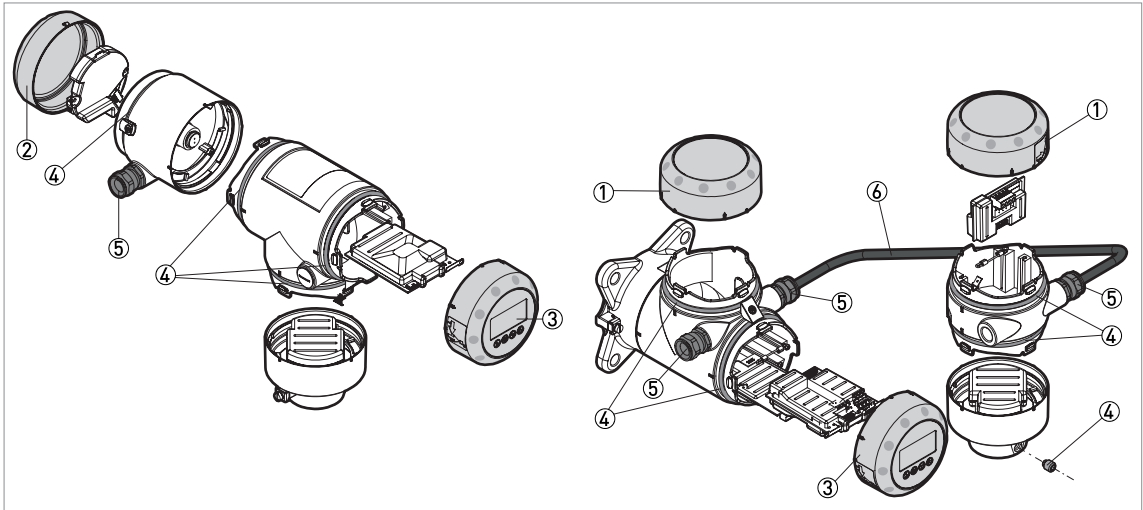

Figure 10-1: Other spare parts

- ① Cover without LCD display
- ② Cover for Ex d module
- ③ Cover with LCD display
- ④ Set of fasteners for housing (lock screw, gaskets)
- ⑤ Cable gland / M20×1.5
- ⑥ Signal cable (Non-Ex: grey, Ex: blue)



DANGER!

Remote version: Make sure that replacement signal cables for Ex-approved devices are supplied by the manufacturer. Use of this signal cable is mandatory.

Item	Description	Quantity	Part reference
①	Cover without LCD display	1	XF2010100
②	Cover for Ex d module ①	1	XF2010200
③	Cover with LCD display (English / German / French / Italian)	1	XF2010300
	Cover with LCD display (English / Spanish / French / Portuguese)	1	XF2010400
	Cover with LCD display (English / Russian / Chinese / Japanese)	1	XF2010500
④	Set of fasteners for housing (lock screw, gaskets)	1 screw, 10 gaskets	XF2010900
⑤	Cable gland / M20×1.5; Plastic; Black; Non-Ex	1	XF2030100
	Cable gland / M20×1.5; Plastic; Blue; Ex i	1	XF2030200
	Cable gland / M20×1.5; Brass; Ex d	1	XF2030300
	Cable gland / M20×1.5; Stainless Steel; Ex d	1	XF2030400
	Cable gland / M20×1.5; Brass; Non-Ex / Ex i	1	XF2030500
	Cable gland / M20×1.5; Stainless Steel; Non-Ex / Ex i	1	XF2030600

Item	Description	Quantity	Part reference
⑥	Signal cable 10 m / 32.8 ft (non-Ex: grey) ②	1	XF2040100
	Signal cable 25 m / 82 ft (non-Ex: grey) ②	1	XF2040200
	Signal cable 50 m / 164 ft (non-Ex: grey) ②	1	XF2040300
	Signal cable 75 m / 246 ft (non-Ex: grey) ②	1	XF2040400
	Signal cable 100 m / 328 ft (non-Ex: grey) ②	1	XF2040500
	Signal cable 10 m / 32.8 ft (Ex: blue) ③	1	XF2040600
	Signal cable 25 m / 82 ft (Ex: blue) ③	1	XF2040700
	Signal cable 50 m / 164 ft (Ex: blue) ③	1	XF2040800
	Signal cable 75 m / 246 ft (Ex: blue) ③	1	XF2040900
	Signal cable 100 m / 328 ft (Ex: blue) ③	1	XF2041000

① Ex d-approved devices only

② For the remote version

③ For the remote version. Make sure that replacement signal cables for Ex-approved devices are supplied by the manufacturer. Use of this signal cable is mandatory.

10.3 Accessories

We supply accessories for this device. When you send an order for a accessories, please give the reference numbers that follow:

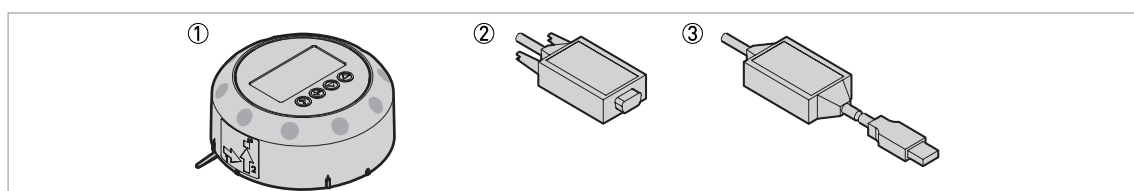

Figure 10-2: Accessories

① HMI service tool

② Viator RS232 / HART converter

③ Viator USB / HART converter

Item	Description	Quantity	Part reference
①	HMI Service tool (English / German / French / Italian) ①	1	XF2010600
	HMI Service tool (English / Spanish / French / Portuguese) ①	1	XF2010700
	HMI Service tool (English / Russian / Chinese / Japanese) ①	1	XF2010800
②	Viator RS232 / HART converter	1	XF2020600
③	Viator USB / HART converter	1	XF2020700

① If the device does not have the LCD display option, use this accessory to change the device configuration

10.4 Glossary

C

Cable This is a wire rope. It is used as a measurement pulse guide.

D

Dielectric constant An electrical property of the product to be measured used in TDR measurement. Also known as ϵ_r , DK and relative permittivity. This gives the strength of the measurement pulse reflected back to the device's signal converter.

Direct mode The device sends a signal along the probe. It receives the reflection of the signal from the surface of the tank contents. The device uses an algorithm to convert the time it takes to receive the signal into a distance. Use of this measurement mode depends on the minimum dielectric constant limit of the probe type. For more data, refer to *Technical data* on page 112. Refer also to **TBF mode**.

Discontinuities These are objects or parts of objects (including the tank) that are in the tank, are possibly in the probe's empty space and can potentially influence the electromagnetic field around the probe. This can cause a measurement error. Also refer to *General requirements* on page 22.

Distance This is a display option. It is the distance from the face of flange to the level (1 product) or the surface of the top product (2 or more products). Refer to the diagrams at the end of this section.

E

Electromagnetic compatibility Defines how much a device influences or is influenced by other devices that generate electromagnetic fields during operation. Refer to European standard EN 61326-1 and EN 61326-2-3 for further details.

Electromagnetic field This is a physical field that is produced by electrically-charged objects and which may affect the behaviour of other objects near to the field.

Empty space A minimum diameter around a probe that should have no objects in it for the device to work correctly. This depends on the probe type. Refer to **Installation** for more details.

H

Hazardous area An area with a potentially explosive atmosphere. Trained personnel can install and use a device in this area. The device must be ordered with the appropriate options. The device requires approvals (ATEX, IECEx, cFMus, NEPSI etc.) related to site specifications. You can find more data about hazardous areas in the Ex Manuals and Ex Certificates of Compliance.

L

Level This is a display option. It is the height from the bottom of the tank (user-defined) to the surface of the top product (Tank height – distance). Refer to the diagrams at the end of this section.

M**Mass**

This is a display option. It shows the total mass of tank contents. Use a mass table or a volume table to display measurement data with mass units.

Measurement pulse

The device transmits a short, low-powered electrical pulse or wave transmitted down a guide to the process. The process (or the probe end if in TBF measurement mode) reflects the pulse back to the device.

O**Operators**

Users who can choose how to display measurements. They cannot configure the device in supervisor mode.

P**Probe**

This is either a metallic cable or rod used to guide the measurement pulse to the process.

Probe length

Ordered length of probe, L, from the face of the flange to end of the guide. If you ordered a cable probe, this includes the counterweight. Refer to the diagrams at the end of this section.

S**Supervisors**

Users who can configure the device in supervisor mode. They cannot configure the device in service mode.

T**TBF mode**

Tank Bottom Following (TBF) mode. If the product has a low dielectric constant, use this mode. TBF mode uses the end of the probe to indirectly measure the tank contents.

TDR

Time domain reflectometry (TDR). The principle used by the device to measure level. For more data, refer to *Measuring principle* on page 111.

Threshold

A number of limits set either manually or automatically by the signal converter to identify the reflected measurement pulses from the level, and the probe end. For configuration data, refer to *Function description* on page 73.

Top dead zone

The distance from the flange to the top limit of the measuring range. Also refer to *Measurement limits* on page 121.

U**Ullage mass**

This is a display option. It shows empty mass or mass of the product that can be put into the tank. Refer to the diagrams at the end of this section.

Ullage volume

This is a display option. It shows the unfilled volume. Refer to the diagrams at the end of this section.

V**Volume**

Total volume of tank contents. Calculated with a volume table.

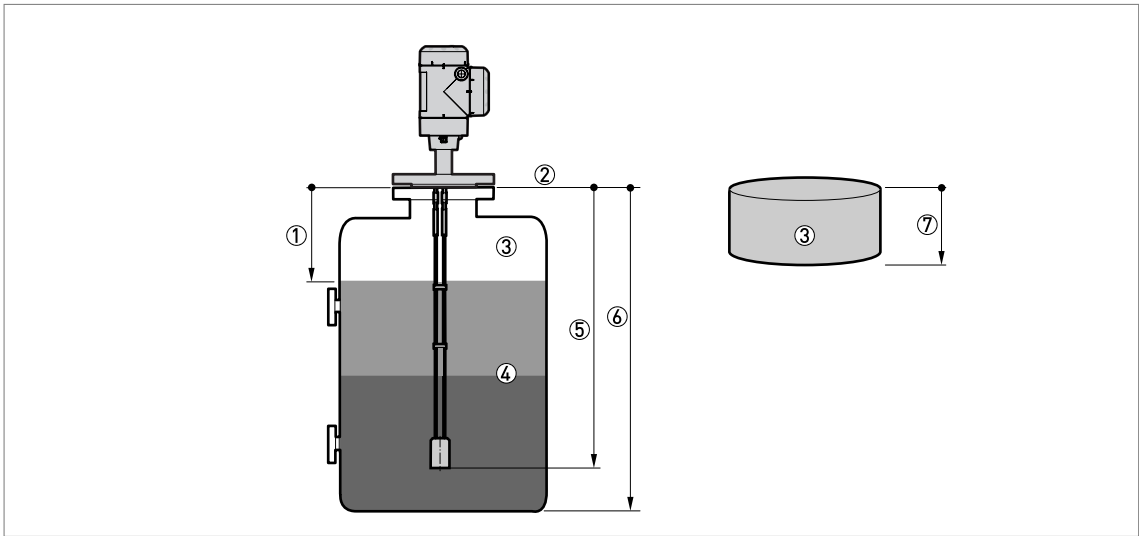

Figure 10-3: Measurement definitions 1

- ① Distance
- ② Flange facing
- ③ Gas (Air)
- ④ Interface
- ⑤ Probe length, L
- ⑥ Tank height
- ⑦ Ullage volume or mass

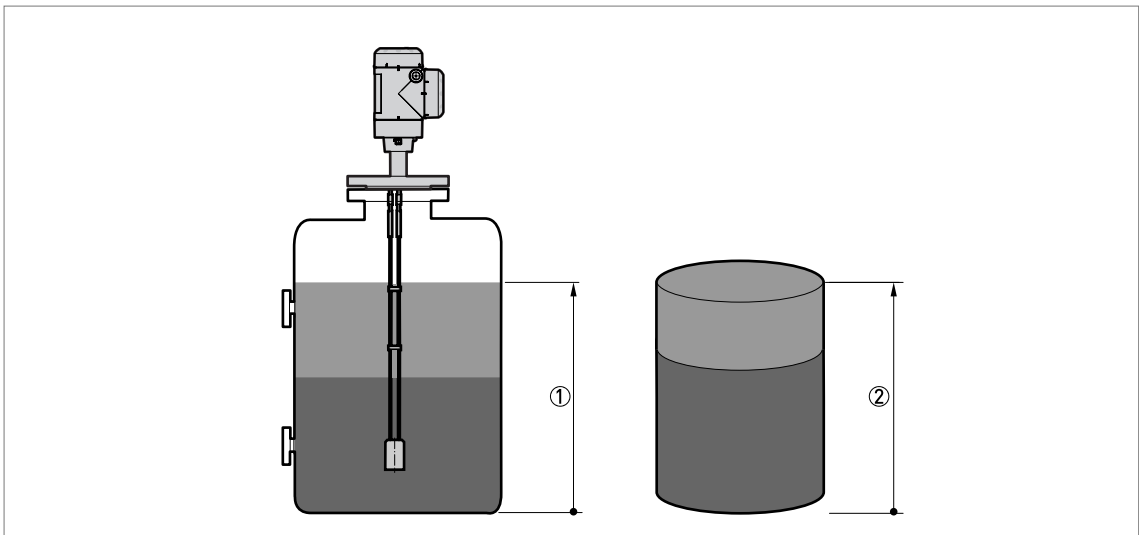

Figure 10-4: Measurement definitions 2

- ① Level
- ② Volume or mass







Hycontrol Ltd
Larchwood House
Orchard Street
Redditch
Worcestershire B98 7DP
United Kingdom
Tel: +44 (0) 1527 406800
Fax: +44 (0) 1527 406810
Email: sales@hycontrol.com
Web: www.hycontrol.com
Company registered in England No: 1755684